

# SUBPRO

SUBSEA PRODUCTION AND PROCESSING

Final  
Report

2015

2023

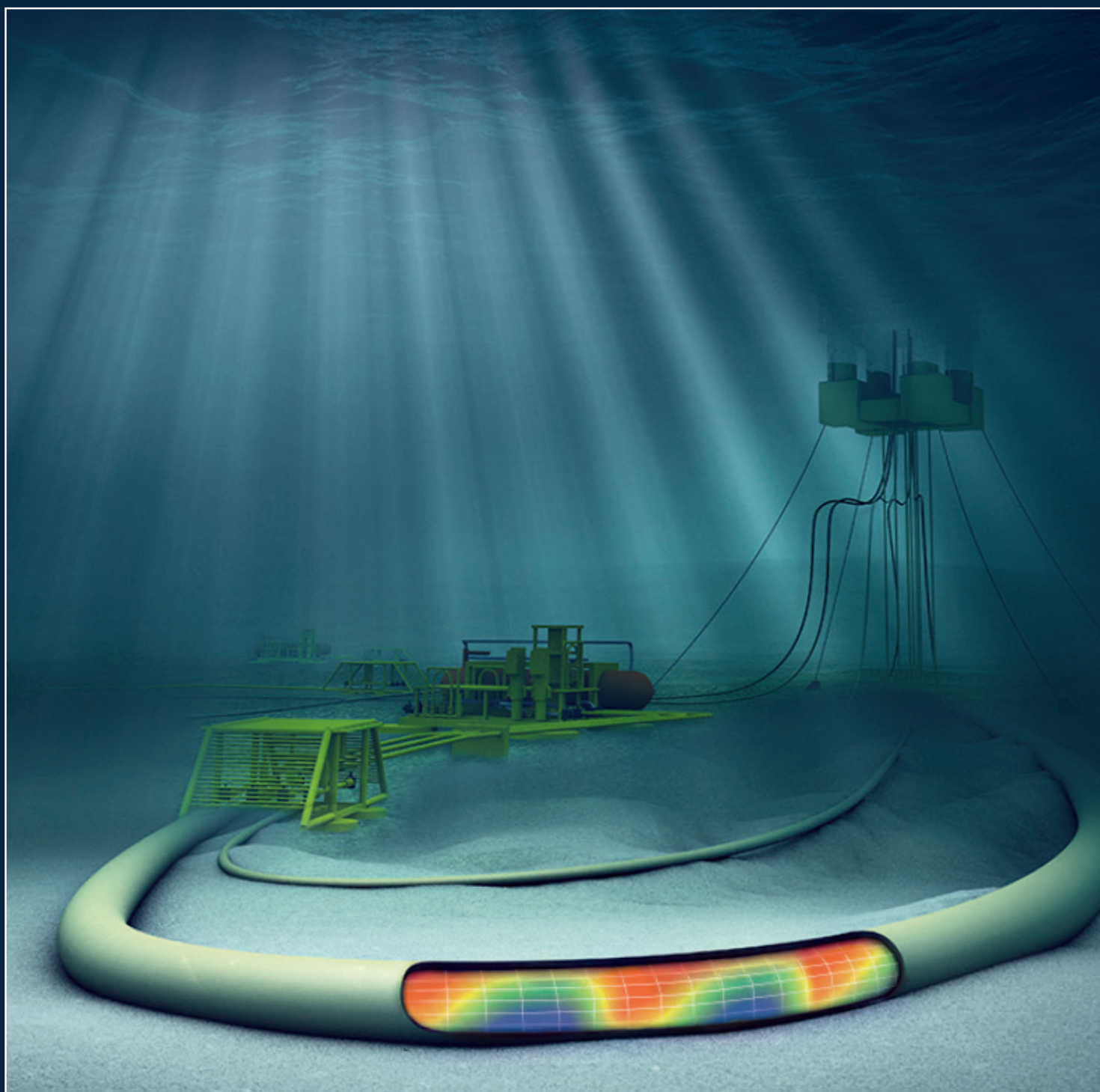



# What is SUBPRO?

SUBPRO was a Centre for research-based innovation (SFI) funded by the Research Council in Norway and seven industrial partners. The Norwegian oil and gas industry has been in the forefront of developing and implementing subsea technology for many years, and the reason for starting up SUBPRO was to bring the academic community in Norway to a similar top international level in selected areas of subsea technology and use this as a basis for further innovation in the industry. Subsea technology covers many areas, and in SUBPRO we focus on five main areas:

- Field architecture
- Reliability, availability maintenance and safety
- Fluid characterization and flow assurance
- Separation process concepts
- Systems control

SUBPRO started up in August 2015 and ended in December 2023, with three PhD students finishing up in 2024. Almost all the research work is done at the Norwegian University of Science and Technology (NTNU) where SUBPRO has funded 35 full time PhD students and 11 Postdoctoral fellows. In addition, about 22 professors and associate professors, 9 researchers and 8 associated doctoral and postdoctoral fellows contributed to the projects on a part time basis, during the period 2015 to 2023.

In addition, SUBPRO has been educating about 15 master students each year, many of which take jobs in the energy industry. The direct transfer of knowledge through hiring of people is a very effective way of contributing to innovation in the companies. In addition, we have started a portfolio of innovation projects, with the aim of practical implementation of the results from the PhD and postdoc works.

Many of the projects in SUBPRO are of fundamental nature and may be exploited by the industry on a longer time perspective. For example, we have several PhD projects related to studying how droplets form and break up. This knowledge is critical for understanding how oil and water can be separated subsea and can be used to improve the design of compact oil-water separators.

SUBPRO is the most comprehensive academic research program in Norway within oil and gas and it is also the largest academic subsea R&D Centre in the world. We had large ambitions, and we think we have fulfilled them!

# Why SUBPRO?

The objective has been to reduce the gaps in knowledge and technology, in order to:

- reduce cost and complexity of subsea field developments
- enable development of new and more demanding oil and gas fields
- increase production and extend life of existing fields
- reduce environmental footprint of subsea field developments
- maintain safety levels

WITH THE GOAL TO ACHIEVE

- accelerated industrial innovation based on fundamental research

Front page picture: Subsea multiphase flow (LedaFlow).  
Photo credit: Kongsberg Digital.  
Picture on page 2 & 3: Illustration of subsea operation, Courtesy of Equinor.

# CONTENT

Chair of the Board, Centre Director, Dean of the faculty of Natural Science	4
Summary in english and norwegian	5
Partners	6
Project structure	7
Field Architecture	10
Reliability, Availability, Maintenance and Safety (RAMS)	24
Separation - Fluid characterization	32
Separation - Process concepts	40
System control	52
AutoPRO	60
PhD education	62
Industry collaboration and innovation	64
International collaboration	66
Governance and Organization	68
Key figures	70
Cost Distribution and Funding	71
HSE	72
Dissemination of Results	74
Publications	76
People in SUBPRO	84

# Vision and goals

The vision and primary goals for SUBPRO is to be a global leader for research-based innovation for subsea production and processing, providing:

- International excellence in fundamental and applied research

- Knowledge, methods, technology and system understanding – as a basis for industrial innovation

- Internationally high level of graduated PhD and Master students





## Chair of the Board

**VANESSA RICHON**

R&D Asset Decarbonization Manager,  
Stavanger Research Center,  
TotalEnergies EP Norge AS

The project SUBPRO started in 2015 and is ending this year in 2024. 8 years of successful innovations, groundbreaking research on subsea technologies, addressing all the bricks of subsea developments.

As an industry partner, TotalEnergies is proud of having been part of this consortium.

Several Innovation projects have been conducted, leading to the industrialization of the research outcomes. This is a proof of success, it shows the strong link between academical research and industrial partners, the focus put on collaboration. The rapid deployment and implementation of newly developed solutions or methodologies is of prime importance for our industry, and this has been addressed very well by SUBPRO.

Thank you for 8 years and we are looking forward to continuing the journey through SUBPRO Zero.



## Centre Director

**PROFESSOR SIGURD SKOGESTAD**

SUBPRO Centre director  
NTNU, Department of Chemical Engineering

SUBPRO has in the 8-year period 2015-2023 been the largest academic research program in the world on subsea oil and gas production and processing. The total budget has been 256 million NOK, financed by industrial partners (54%), the Norwegian Research Council (31%) and NTNU (15%). As a center for research-based innovation (SFI) the center has been unique in that NTNU is the sole research partner. However, the project has been diverse and has included 3 Faculties, 4 Departments and 25 Professors at NTNU.

Looking back, SUBPRO has reached most of the goals we set at the start in 2015. The research topics have been very much according to the original plan and we have reached our targets when it comes to researcher training. Our original target was to educate 40 PhD students. The result is 35, but on the other hand we have trained more postdocs (11) and researchers (16) than originally planned. There has also been 12 innovation projects with the aim of getting the results from the PhD theses into industrial practice. Most of the PhDs and postdocs has found positions in the oil and gas industry. In addition, the center has educated about 120 Master candidates.

The proof of the success of the center, as seen from the industry, is that most of the partners has decided to join the fully industry financed SUBPRO Zero project, which will extend the results from SUBPRO into a greener future.



## Dean of the Faculty of Natural Sciences

**PROFESSOR ØYVIND WEIBY GREGERSEN**

Dean of The Faculty of Natural Sciences  
NTNU, Department of Chemical Engineering

The Centre for research-based innovation, SUBPRO has been highly successful. The close collaboration between nine industrial partners, professors, PhD-students and master students across different academic fields has created a strong academic environment closely coupled to industrial needs and insights. This environment has produced an impressive amount of research results, published articles, provided ideas to be further developed industrially and educated PhDs and masters with a highly relevant background for the Norwegian industry. The Norwegian oil and gas industry has been in the front developing and implementing subsea technology for many years. This now has a match in academic environments at NTNU in the selected focus areas. Field architecture, Reliability, availability maintenance and safety, Fluid characterization and flow assurance, Separation process concepts and Systems control.

## Summary (in English)

The Norwegian oil and gas industry is on the global front when it comes to the development and application of subsea technology for oil and gas. However, there is still need for new and innovative solutions to increase recovery and production from existing fields, reduce costs for new field developments, develop new demanding oil and gas fields (eg Arctic coasts, deep water, etc.) and maintain reliability, safety, energy efficiency and the environment.

In order to accelerate innovation in the oil and gas industry in this field, a research-based innovation center (SFI), SUBPRO, has been established in collaboration with NTNU and 7 international oil companies / supplier companies, with support from the Norwegian Research Council. The center develops new knowledge, methods and tools for the design and operation of systems for subsea production and processing. The research covers a wide range from fundamental studies on drop dynamics, gas, oil and water treatment, process automation and control, field architecture and reliability to safety and environment. The center combines the industrial partners' advanced seabed expertise and experience with interdisciplinary research carried out by four internationally recognized academic environments at NTNU (Department of Chemical Process Technology, Department of Engineering Cybernetics, Department of Earth Science and Petroleum and the Department of Mechanical and Production Engineering). Since 2015, about a 100 people at NTNU have been involved in the SUBPRO center: 35 doctoral fellows, 11 postdoctoral fellows, 9 researchers, 8 associated doctoral and postdoctoral fellows, about 15 Master's students (annually), and 22 professors.

The center is organized in five research areas that have been selected in close cooperation between the industrial partners and NTNU:

- Field architecture for seabed systems
- Reliability, Availability, Maintenance and Security (RAMS)
- Fluid characterization for separation and flow assurance
- Concepts for separation processes
- Process automation and control, digitization

The center started in August 2015 and has been planned for 8 years. So far, 189 academic publications have been produced.

The center has been collaborating with 18 outstanding international universities (MIT and Carnegie Mellon in the United States, 5 leading universities in Brazil, Imperial College, MINES ParisTech, University of Troyes, University of Wageningen, Eindhoven University of Technology, Aalborg University, University of Aalen, and ETH Zurich, 3 universities from China.

Results are communicated to the industrial partners through reference groups and workshops. Results from the center have been disseminated at industrial conferences such as the Subsea Valley conference, Underwater Technology Conference, OG21 and Tekna seminars. The center also cooperates with the Global Center of Expertise Ocean Technology.

The center has triggered associated projects, such as the INTPART project "Brazil Norway Subsea Operations Consortium", Safety4 - Demonstrating Safety of New Subsea Technology and AutoPRO - Digitalization for Prognosis and Autonomous Production Optimization in Offshore Production Systems. Subsea Operations Consortium" and Safety4 - Demonstrating Safety of New Subsea Technology.

## Summary (in Norwegian)

Den norske olje- og gassindustrien er i verdensfronten når det gjelder utvikling og anvendelse av undervannsteknologi for olje- og gassfeltutbygginger. Det er likevel fortsatt behov for nye og innovative løsninger for å øke utvinningen og produksjonen fra eksisterende felt, redusere kostnader for nye feltutbygginger, utvikle nye og mer krevende olje- og gassfelt (f. eks. arktiske strøk, dypvann osv.) og ivareta pålitelighet, sikkerhet, energieffektivisering og miljø.

For å akselerere innovasjonen innen olje- og gassindustrien på dette feltet, er det etablert et senter for forskningsbasert innovasjon (SFI), SUBPRO, i samarbeid mellom NTNU 7 fra internasjonale oljeselskap/leverandørselskap, og med støtte fra Norges forskningsråd.

Senteret utvikler ny kunnskap, nye metoder og verktøy for design og operasjon av systemer for undervanns produksjon og prosessering. Forskingen dekker et bredt spekter fra fundamentale studier på dråpedynamikk, til gass-, olje- og vannbehandling, prosess automatisering og -kontroll, feltarkitektur og pålitelighet, sikkerhet og miljø. Senteret kombinerer industripartnerne avanserte havbunns-kompetanse og -erfaring med tverrfaglig forskning utført av fire internasjonalt anerkjente fagmiljøer ved NTNU (Institutt for kjemisk prosesssteknologi, Institutt for teknisk cybernetikk, Institutt for geovitenskap og petroleum og Institutt for maskin- og produksjonsteknikk). Ca. 100 personer på NTNU har vært involvert i SUBPRO-senteret 35 doktorgradsstipendiater, 11 postdoktorer, 9 forskere, 8 assosiert doktorgradsstipendiater og postdoktorer, ca. 15 Masterstudenter (årlig) og 22 professorer.

Senteret er organisert i fem forskningsområder som er valgt ut i nært samarbeid mellom industripartnerne og NTNU:

- Feltarkitektur for havbunns-systemer
- Pålitelighet, tilgjengelighet, vedlikehold og sikkerhet (RAMS)
- Fluid karakterisering for separasjon og flow assurance
- Konsepter for separasjonsprosesser
- Prosess-automatisering og -kontroll, digitalisering

Senteret startet opp i august 2015 og er planlagt for 8 år. Det er til nå produsert 189 akademiske publikasjoner.

Senteret samarbeider med 18 fremragende internasjonale universiteter (MIT og Carnegie Mellon i USA, 5 ledende universiteter i Brasil, Imperial College, MINES ParisTech, University of Troyes, University of Wageningen, Eindhoven University of Technology, Aalborg Universitet, University of Aalen, ETH Zurich og 3 universiteter fra Kina.

Resultater blir formidlet til industripartnerne gjennom referansegrupper og workshops. Resultater fra senteret har blitt formidlet på industrielle konferanser som Subsea Valley-konferansen, Underwater Technology Conference, OG21 og Tekna-seminarer. Senteret samarbeider også med Global Centre of Expertise Ocean Technology.

Senteret har utløst assosierte prosjekter, som INTPART-prosjektet «Brazil Norway Subsea Operations Consortium», Safety4 - Demonstrating Safety of New Subsea Technology og AutoPRO - Digitalization for Prognosis and Autonomous Production Optimization in Offshore Production Systems.

# Partners



(From 2015 until 2017)  
Merged with Neptune Energy from 2017

(From 2018 until 2019)  
Merged with Neptune Energy from 2019

(From 2015 until 2022)  
Merged with Aker BP from 2022

(From 2015 until 2017)

(From 2015 until 2018)

(From 2020 until 2022)



# Project structure

RESEARCH AREA				
Field architecture <i>Prof. Sigbjørn Sangesland</i>	Reliability, Availability, Maintenance and Safety <i>Prof. Jørn Vatn</i>	Separation - fluid characterization <i>Prof. Gisle Øye</i>	Separation - process concepts <i>Prof. Hugo Jakobsen</i>	System control <i>Prof. Johannes Jäschke</i>
PROJECTS				
<b>1.1 Subsea gate box</b> Postdoc Mariana Diaz Prof. Sigbjørn Sangesland	<b>3.1 New safety and control philosophy for subsea systems</b> Postdoc Hyungju Kim Prof. Mary A. Lundteigen	<b>2.1 Produced water quality and injectivity</b> PhD Marcin Dudek Prof. Gisle Øye	<b>2.4 Membranes for gas dehydration (modeling)</b> PhD Kristin Dalane Prof. Liyuan Deng/ Prof. Magne Hillestad	<b>3.4 Dynamic simulation model library</b> Postdoc Christoph Backi Prof. Sigurd Skogestad
<b>1.1.b Optimization of field development and subsea layout</b> PhD Leonardo Sales Assoc. Prof. Milan Stanko	<b>3.1.b Safety-critical systems for unmanned facilities</b> PhD Tae Hwan Lee Prof. Mary A. Lundteigen	<b>2.1.b Influence of chemicals on produced water quality</b> Postdoc Marcin Dudek Prof. Gisle Øye	<b>2.4.b Membrane testing for gas dehydration</b> PhD Mahdi Ahmadi Prof. Liyuan Deng	<b>3.5 Modelling for control of subsea processes</b> PhD Torstein Kristoffersen Assoc. Prof. Christian Holden
<b>1.1.c Enabling technology for low-cost subsea field development</b> Postdoc Lucas C. Seviliano Prof. Sigbjørn Sangesland	<b>3.1.c Digital twin for safety demonstrations</b> PhD Ludvig Bjørklund Prof. Mary A. Lundteigen	<b>2.1.c Re-inj. of prod. water - disp. in porous media</b> PhD Ilgar Azizov Prof. Gisle Øye	<b>2.4.c Natural gas dehydration with the use of membranes</b> Postdoc Mahdi Ahmadi Prof. Magne Hillestad	<b>3.5.b Automatic control of hydrocyclones for produced water treatment</b> PhD Mishiga Vallabhan Assoc. Prof. Christian Holden
<b>1.1.d Valves and materials - design concepts for simplifications</b> PhD Mehman Ahmadi Prof. Tor Berge Gjersvik	<b>3.1.d Digital twin qualification for maintenance</b> PhD Jie Liu, Prof. Shen Yin	<b>2.1.d Gas flotation for subsea produced water treatment</b> PhD Martina Piccoli Prof. Gisle Øye	<b>2.5 Combined H<sub>2</sub>S and hydrate control</b> PhD Eirini Skylogianni Prof. Hanna Knuutila	<b>3.5.c Energy-optimal subsea production and processing</b> PhD Asli Karacelik Assoc. Prof. Christian Holden
<b>1.2 Field development concepts</b> PhD Diana Gonzalez Assoc. Prof. Milan Stanko	<b>3.1.d Digital twin qualification for maintenance</b> PhD Jie Liu, Prof. Shen Yin	<b>2.2 Modelling of wax crystallization and deposition</b> PhD Jost Ruwoldt Prof. Johan Sjöblom	<b>2.6.b Mechanistic modeling of fluid particle breakage</b> Postdoc Hanieh Karbas Prof. Hugo A. Jakobsen	<b>3.5.c Energy-optimal subsea production and processing</b> PhD Asli Karacelik Assoc. Prof. Christian Holden
<b>1.3 Multiphase boosting models</b> PhD Gilberto Nunez Prof. Sigbjørn Sangesland	<b>3.2 Reliability and availability in design</b> PhD Juntao Zhang Prof. Mary A. Lundteigen	<b>2.2.b Flow improvers for transport of waxy crudes</b> PhD George Claudiu Savulescu Prof. Gisle Øye	<b>2.7 Experiments on fluid particle breakage</b> PhD Eirik Helno Herø Prof. Hugo A. Jakobsen	<b>3.6 Adaptive control of subsea processes</b> PhD Sveinung J. Ohrem Assoc. Prof. Christian Holden
<b>1.4 Subsea field layout optimization</b> PhD Haoge Liu Prof. Tor B. Gjersvik	<b>3.3 Condition and prognostic maintenance</b> PhD Yun Zhang Prof. Anne Barros	<b>2.3 Sequential separation</b> PhD Are Bertheussen Prof. Johan Sjöblom	<b>2.9 Compact separation</b> PhD Håvard S. Skjefstad Assoc. Prof. Milan Stanko	<b>3.7 Estimation of unmeasured variables</b> PhD Tamal Das Prof. Johannes Jäschke
<b>1.4.b Subsea field layout optimization (Innovation project)</b> Researcher Haoge Liu Prof. Tor B. Gjersvik and Adjunct Prof. Audun Faanes	<b>3.3.b Optimizing condition monitoring</b> PhD Himanshu Srivastav Prof. Anne Barros	<b>2.8 Modeling of coalescence</b> Postdoc Aleksandar Mehandzhiyski Yordanov Assoc. Prof. Brian A. Grimes	<b>2.9.b Subsea bulk oil-water separation</b> PhD Hamidreza Asaadian Assoc. Prof. Milan Stanko	<b>3.7.b Enhanced virtual flow metering</b> PhD Timur Bikmukhametov Prof. Johannes Jäschke
<b>1.1.e Operation and design of oil fields with power constraints</b> Researcher Abraham Parra Assoc. Prof. Milan Stanko	<b>3.3.c Estimation and optimization of remaining useful life</b> Postdoc Xingheng Liu Prof. Jørn Vatn	<b>2.8.b A digital twin library for oil/water emulsion separation and transport</b> PhD Moein Assar Assoc. Prof. Brian A. Grimes	<b>2.6 Particle breakup; turbulence and image analysis</b> Researchers Nicolás La Forgia and Suparna Paul Prof. Hugo A. Jakobsen	<b>3.7.c High-accuracy virtual flow metering</b> PhD Md Rizwan Assoc. Prof. Christian Holden
<b>Subsea CO<sub>2</sub> injection</b> Researcher Tamires de Souza Alves da Silva PhD Sigbjørn Sangesland	<b>3.3.d Safety and security of autonomous systems against cyberphysical attacks</b> Researcher Xingheng Liu Prof. Jørn Vatn and Prof. Shen Yin	<b>2.1.c Re-injection of produced water - co flow of particles and droplets visualized using microfluidic and advanced image analysis methods</b> Researcher Husnain Ahmad Prof. Gisle Øye	<b>2.4.c Natural gas dehydration with the use of membranes</b> Researcher Niloufar K. Rezaei Prof. Magne Hillestad and Dr. Eivind Johannessen, Equinor	<b>3.8 Control for extending component life</b> PhD Adriaen Verheyleweghen Prof. Johannes Jäschke
<b>Associated project Data driven prognostics and health mgmt. in safety systems</b> PhD M. Gibran Alfarazi Prof. Shen Yin	<b>Spin-off: SAFETY 4.0 - Ensuring functional safety of novel technologies</b> PhD Nanda Zikrullah Prof. Mary Ann Lundteigen	<b>2.1.c Re-injection of produced water - co flow of particles and droplets visualized using microfluidic and advanced image analysis methods</b> Researcher Husnain Ahmad Prof. Gisle Øye	<b>2.6 Particle breakup; turbulence and image analysis</b> Researchers Nicolás La Forgia and Suparna Paul Prof. Hugo A. Jakobsen	<b>3.8.b Experimental validation of methods - Remaining Useful Life (RUL)</b> Postdoc José Matias Prof. Johannes Jäschke
			<b>Feasibility study of blue H<sub>2</sub></b> Researchers Diego Di Domenico Pinto and Juliette Limpach Prof. Hanna K. Knuutila	<b>Digital Twins for autonomous operations</b> Researcher Carine de Menezes Rebello Prof. Johannes Jäschke
				<b>Spin-off project: AutoPRO</b> PhD Evren Turan (SC) PhD Emefon Dan (RAMS) Prof. Johannes Jäschke/ Prof. Yiliu Liu/ Ind. PhD Supervisor Edmary Altamiranda



# SUBPRO Zero

## Sustainable Bridge PROgram towards Zero emissions



**Johannes Jäschke**, Professor, Dept. of Chemical Engineering and  
**Milan Stanko**, Associate Professor, Dept. of Geoscience and Petroleum

SUBPRO-Zero is a 3-year research project (2023-2026) funded by industry and NTNU. The basis for SUBPRO Zero is the highly successful SUBPRO Center for Research-based Innovation (SFI) on Subsea Production and Processing (2015-2023) which was funded by industry, NTNU and the Research Council of Norway. As funding for SUBPRO expires in 2023, the consortium decided to organize a follow-up project with a more sustainable focus, SUBPRO-Zero (Sustainable Bridge PROgram towards Zero emissions).

In SUBPRO-Zero, NTNU and industry partners join forces to establish a common research program. Our mission is to conduct fundamental and applied research to contribute to net-zero emissions in the offshore industry. Embedded in a framework of a Value Chain Approach, our activities focus on the following areas:

- Low complexity blue hydrogen production (e.g., for offshore applications), gas treatment, and carbon capture (zero emission to air)
- Water treatment, including re-injection (zero emission to water)
- Field architecture, optimization, and energy efficiency
- Digitalization, Systems Control, and RAMS (Reliability, Availability, Maintenance and Safety)

The new SUBPRO-Zero activities started in Autumn 2023 and are organized similarly to the SUBPRO SFI, i.e. the research is performed mainly by PhD students and Post-docs at NTNU. There are 10 PhD and Postdoc projects planned for execution. The strategic decisions about research activities are made by a board consisting of representatives of the partners.

Five operator companies and three supplier companies have so far agreed to join the consortium during this first period: Equinor, Aker BP, Neptune Energy, Total Energies, Vår Energi, DNV, Aker Solutions, Kongsberg Digital.

In the longer term, we are looking into the possibility for a further extension where also the research council is included (for example, through an FME or SFI project).

For more information see <https://www.ntnu.edu/subpro-zero>

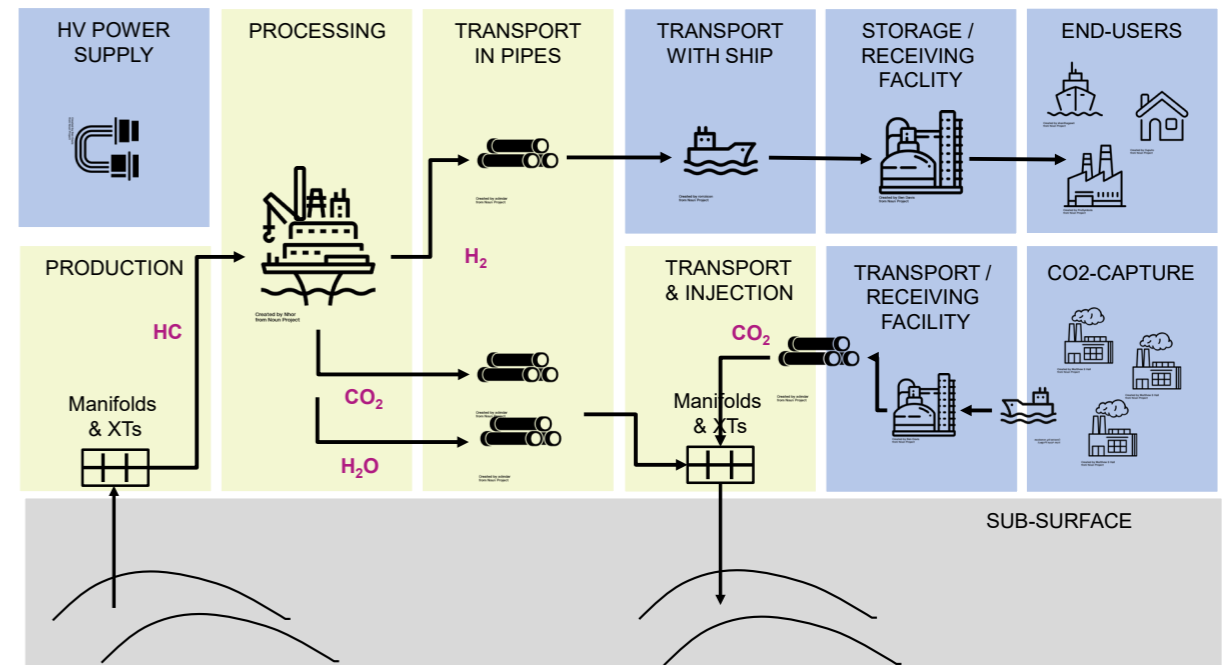

Value Chain Approach: The scope of SUBPRO-Zero is shown in yellow.

The following projects will be realized in the first round, and more may be started, for example if new partners join:

- Low CO<sub>2</sub> emission platforms (PhD)
- Gas Flotation for Subsea Produced Water Treatment II (PhD)
- Decision-support methods for holistic water management - water value chain (Postdoc)
- Complete subsea separation (PhD)
- Lean designs for carbon dioxide subsea injection systems (Postdoc)
- Multi-scale Virtual Flow Metering for optimal decision-making (PhD)
- Design and operation of subsea oil and gas fields powered by renewable sources (Postdoc)
- Systematic methods for smart management of CO<sub>2</sub> transport and injection systems (PhD)
- Optimal flow regime control in oil transport (PhD)
- Incorporating artificial intelligence in Safety-critical systems for CO<sub>2</sub> capture, injection, and storage (PhD)



RESEARCH AREA

# Field architecture

The objective for this research area is to develop new concepts and configurations for subsea production/processing systems and new optimization tools for subsea field development.



**Professor Sigbjørn Sangesland**  
Research Area Manager  
Department of Geoscience and Petroleum, NTNU

## PROJECT MANAGERS AND SUPERVISORS

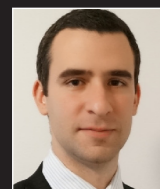

Assoc. Prof. Milan Stanko,  
Department of Geoscience and Petroleum, NTNU



Tor Berge Gjersvik,  
Department of Geoscience and Petroleum, NTNU



Postdoctoral fellow Jesus de Andrade



Professor Johannes Jäschke,  
Department of Chemical Engineering, NTNU



Adjunct Prof. Audun Faanes,  
Equinor

## Project overview

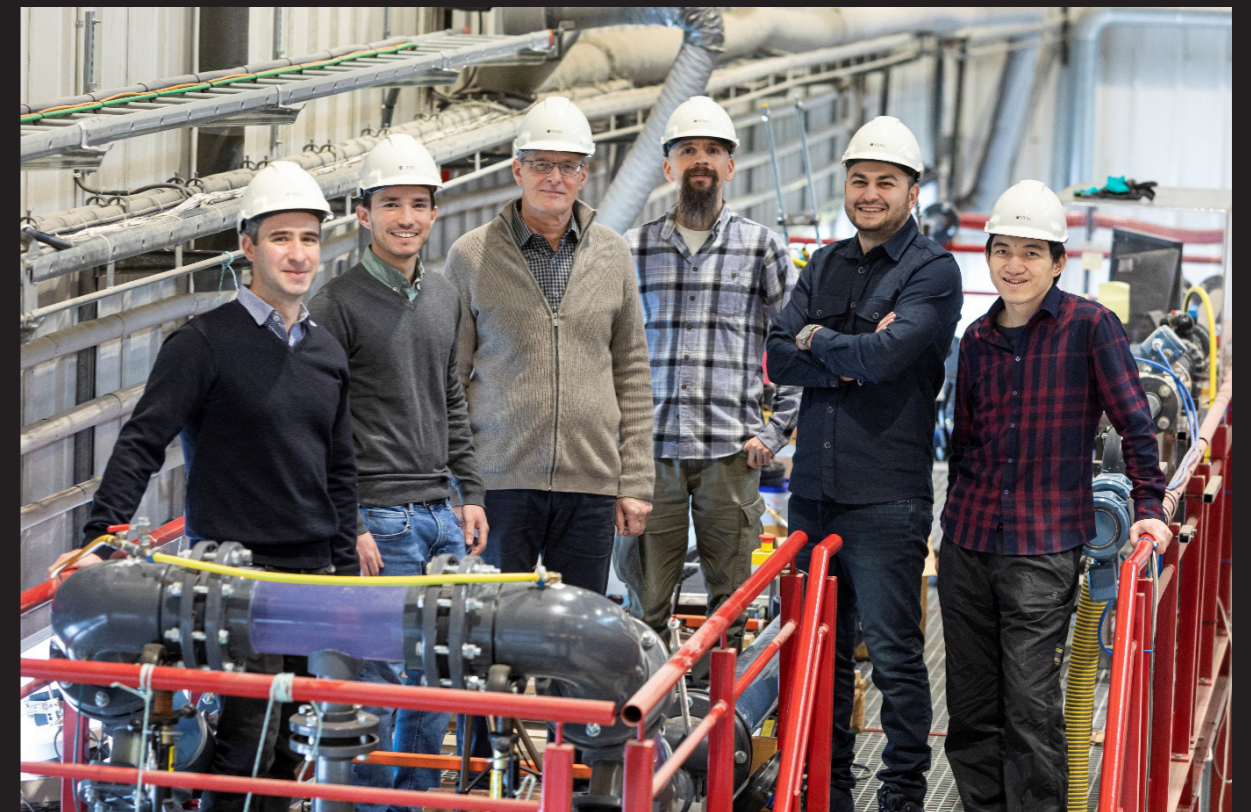
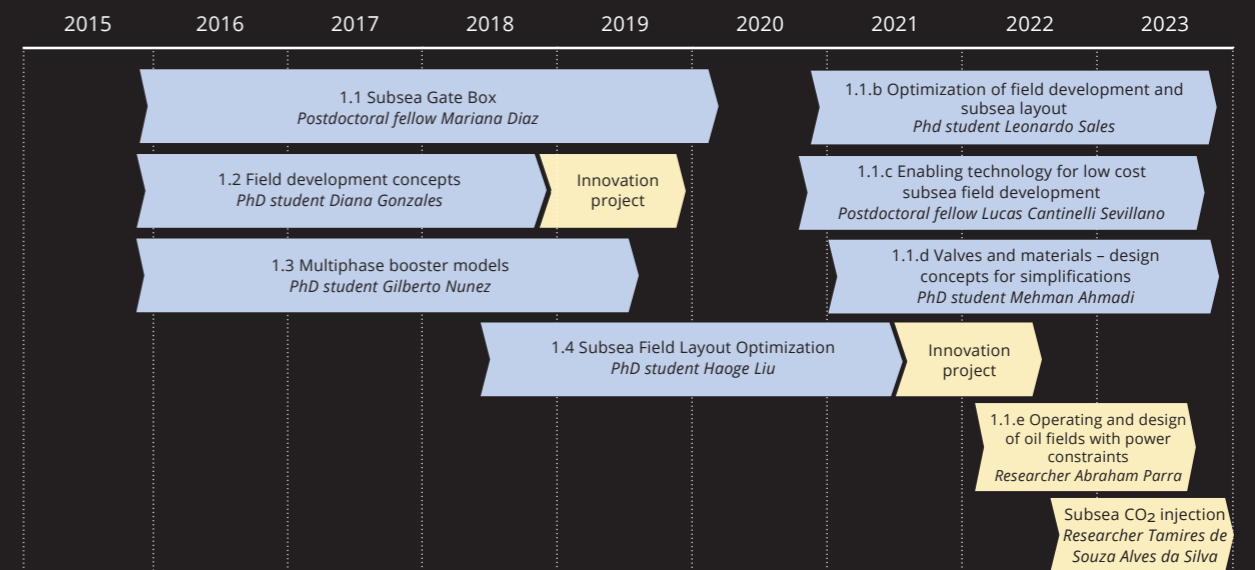

**The Field Architecture team**, in the laboratory of Department of Geoscience and Petroleum at NTNU

From the left: Associate Professor Milan Stanko, PhD student Leonardo Sales, Professor Sigbjørn Sangesland, Postdoctoral fellow Lucas Cantinelli Sevilano, PhD student Mehman Ahmadi and Researcher Haoge Liu.

Professor Tor Berge Gjersvik, Professor Johannes Jäschke and Adjunkt Professor Audun Faanes were not present when the photo was taken.



# The subsea gate box

## A possible way to enhanced production.

 **Green Shift Impact:** The Subsea Gate Box (SGB) could contribute to energy efficiency by improving the performance of the subsea processes and equipment.



Postdoctoral fellow:  
**Mariana Diaz**



PhD student:  
**Leonardo Sales**

### BACKGROUND FOR THE PROJECT

During the early phases of field development, important decisions are taken about the production system configuration and characteristics while the knowledge about the subsurface is very limited. Therefore, design decisions are often based on information that is likely to be updated in time. It is therefore important to include flexibility in the production and processing system to effectively manage the heterogeneity of the field and the uncertainty of the system conditions over time.

Standard field architectures often consider central subsea processing units which tend to create a strong interdependence of the flow rates and production pressures of the individual wells. Such a strategy might lead to a sub-optimal use of the naturally available reservoir energy. Therefore, the Postdoc project presented a novel concept where subsea wells with large heterogeneous performance are hydraulically decoupled from the main network by using a field architecture with decentralized subsea processing modules. This approach, called the Subsea Gate Box (SGB), allows to increase the production management flexibility by expanding the possible production strategies, considering both production constraints and reservoir dynamics, and increasing energy efficiency to improve the resource utilization. The postdoc project aimed to evaluate the SGB concept in terms of its applicability, technical feasibility and potential within subsea field developments and to develop a design methodology for the SGB.

### MAIN RESULTS

The Postdoc project of Mariana Diaz showed that the SGB can achieve better economic performance when compared to centralized subsea processing architectures. The project also performed a technical feasibility analysis

considering available equipment, required interfaces and reliability. In addition, the project developed a method to determine design of subsea systems with the SGB. The proposed methodology enables a systematic and automated screening process that allows exploring the entire domain, ranking the alternatives, and identifying the optimal or near optimal solutions in a consistent manner. See ( Figure 1 and Figure 2). The method used scenario-screening with a combination of Evolutionary Algorithms (EA) and Integrated Production Modelling (IPM) to automate case generation, field architecture scenario screening, and optimization. After close collaboration with Aker BP, the method was packed in a computational program in MatLab called OFFA - Optimal & Flexible Field Architectures.

The PhD project of Leonardo Sales did further testing and debugging of the tool and evaluated the effect of uncertainty on the results.

### INDUSTRY COLLABORATION AND INNOVATION

The SUBPRO industry partners and especially Equinor, Aker BP, Aker Solutions, Total Energies, and Lundin have been key collaborators to outline the scope of the project and identify the necessities of the industry in this area.

### Commercial software development

Based on the results from the Subsea Gate Box postdoc and PhD projects, Aker BP has developed the OFFA "Optimal and Flexible Field Architectures", a solution that uses evolutionary algorithms to generate, screen and optimize concept scenarios, using decentralized subsea processing, considering production potential and development cost. The development has been completed internally and it is being implemented and qualified as a commercial software solution.

### SELECTED PUBLICATIONS

- Diaz, Mariana J. C., Milan Stanko and Sigbjørn Sangesland. "Exploring New Concepts in Subsea Field Architecture". In: Offshore Technology Conference Houston, USA. doi: 10.4043/28702-MS. (2018).
- Leonardo, Sales; Johannes, Jäschke; Milan, Stanko. "Designing Subsea Processing Systems Using a Hybrid Genetic Algorithm". 41st International Conference on Ocean, Offshore and Arctic Engineering (OMAE2022); 2022-06-05 - 2022-06-10.
- Díaz Arias MJC, dos Santos AM, Altamiranda E. "Evolutionary Algorithm to Support Field Architecture Scenario Screening Automation and Optimization Using Decentralized Subsea Processing Modules". Processes. 2021; 9(1):184. <https://doi.org/10.3390/pr9010184>

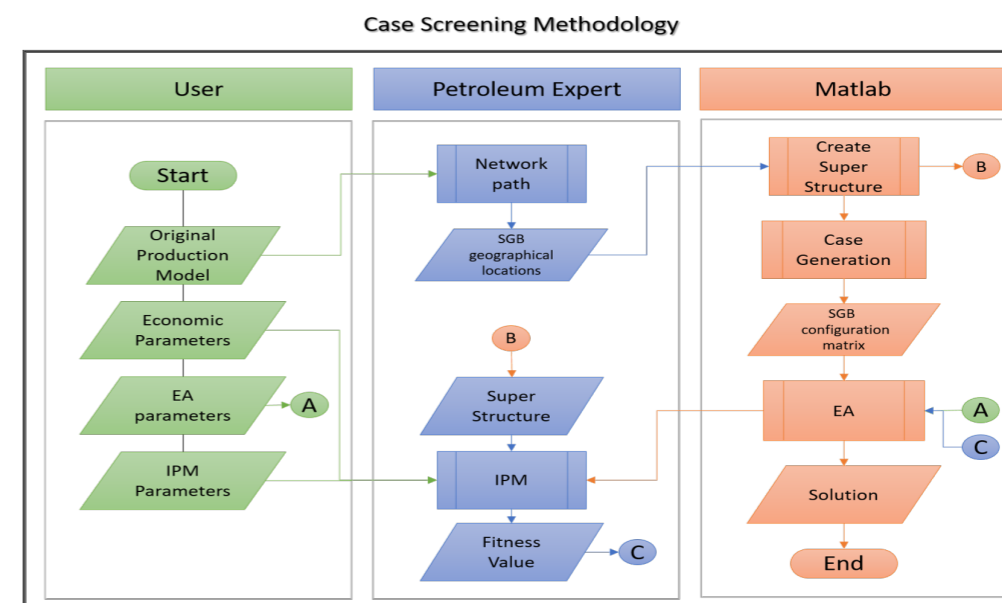

Figure 1: Flow diagram of the Case Generation and Scenario Screening Methodology. (\* Petroleum Experts is a commercially available software for the study of hydrocarbon production systems)

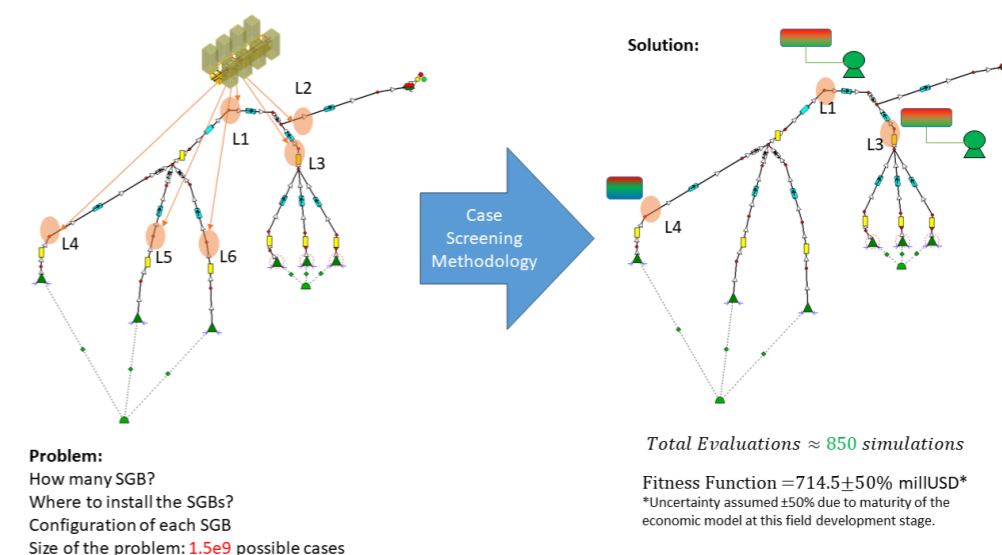

Figure 2: Example of defining the field architecture of a given development using the screening methodology



# Methods for early-phase field development



PhD student:  
**Diana Gonzalez**



PhD student:  
**Leonardo Sales**

## INTRODUCTION

In these two PhD projects, new methodologies to provide decision support during early field development using integrated value chain models, optimization and quantifying uncertainty have been developed and tested (Figure 7). The methods allow to compute probabilistic distributions of project economic value, optimal production and drilling schedules that maximize economic value. This information can be used as a base to e.g. determine optimal development concept, capacity of processing facilities and to decide whether to go forward or not with the development.

The methods create a proxy of the field's production performance using interpolation on data points generated using the output of complex and detailed models. The optimization on the proxy runs fast which allows to consider multiple uncertainties using sampling or stochastic optimization. The method was tested and demonstrated using three use cases: a remote low energy offshore oil reservoir (proposed by Equinor), a synthetic 3-reservoir field in the North Sea (proposed by Aker Solutions) and an Offshore Brazilian deepwater field (available in the literature). The research results triggered follow-up research in the BRU21 research program.

PhD researcher Leonardo Sales also worked on decision support methods using model-based optimization to decide on layout, configuration and requirements of subsea systems with processing equipment. The methods were demonstrated on a synthetic case based on the Goliat field. Some key findings are that accounting for reliability and maintenance have a significant impact on the results and that a hybrid two-step optimization reduced significantly the running time.

## INNOVATION PROJECT

The PhD project of Diana Gonzalez has been followed up by a 6-month innovation project, which resulted in a server-based tool with a user-friendly interface and implementation of some models in an Aker Solutions software.

## SELECTED PUBLICATIONS

- González, D, Stanko, M., Hoffmann. "A. Decision support method for early-phase design of offshore hydrocarbon fields using model-based optimization". J Petrol Explor Prod Technol (2019). <https://doi.org/10.1007/s13202-019-0613-1>
- Angga, I Gusti Agung Gede; Stanko Wolf, Milan Edvard. "Automated decision support methodology for early planning phase of a multi-reservoir field". Journal of Petroleum Science and Engineering. vol. 205. (2021).
- Leonardo Sales, Johannes Jäschke, Milan Stanko. "Early field planning using optimisation and considering uncertainties: Study case: Offshore deepwater field in Brazil". Journal of Petroleum Science and Engineering, Volume 207, 2021, 109058, ISSN 0920-4105. <https://doi.org/10.1016/j.petrol.2021.109058>.

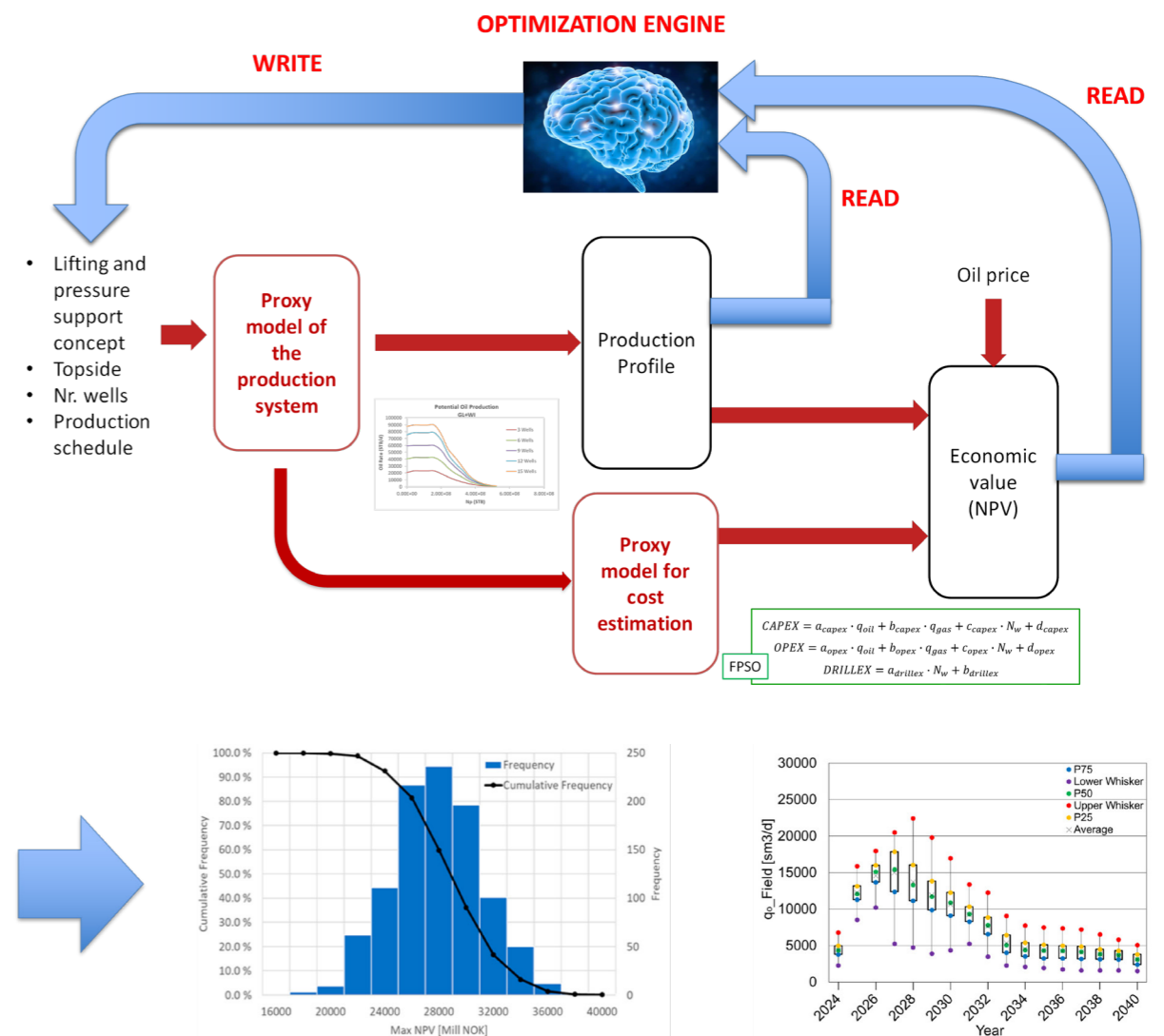

Figure 7 Methodology to provide decision support during early field development using integrated models, optimization and quantification of uncertainty

# Optimizing subsea layout to minimize risk and cost



PhD student/Researcher:  
**Haoge Liu**

## PROJECT BACKGROUND AND RESEARCH MOTIVATION

Subsea layout design plays one of the most important roles in minimizing the overall cost of offshore field developments. From the reservoir to the topside facility, the layout design mainly includes well trajectories, positions of drilling sites/templates and manifolds, flowlines, and cable routing, etc.

In early stages of field development studies, different scenarios or subsea field layouts should be investigated to seek out “the best solution.” However, once the number of wells and manifolds increase, such studies become challenging due to the time and effort involved.

The overall problem consists of two simultaneous optimization tasks. One challenge is to determine what wells (or completion intervals) to allocate to what template/manifold (“location-allocation-problem”) as illustrated below in figure 3.

The next challenge then is to determine the optimal position for each manifold to minimize the drilling cost to the allocated subsurface completion intervals (“1-site-n-wells problem”). The optimal template position is the one that minimizes the sum of the wellbore lengths.

At the same time, the relative positions of the subsea manifolds themselves impact on subsea infrastructure cost through flowlines, control lines and other cost items sensitive to lengths or distances. To handle this, we have to solve the combinatory problem which is well known for its NP-hardness as the location-allocation problem.

## RESEARCH AND RESULTS

The research and results in the form of the new methods developed, are fully documented in the 3 peer-reviewed papers that became the basis for Dr. Liu’s doctoral thesis and dissertation. In the first paper, Dr. Liu gives a comprehensive documentation of his work to extend the “2D Dubins path” to a complete 3D application. The Dubins principle states that the shortest distance between two

directional positions (points and directions) in a plane is a combination of arcs and straight lines. Dr. Liu extended the formulations from 2D to 3D using very compact vector formulations as shown in figure 4. design software to get the cost contour of each well under the complex constraints, then feed the cost contours into the BLP model to decide the optimal layout.

The second major achievement is the development of a novel method to reduce the NP-hard problem formulated as “Mixed-Integer Nonlinear Programming” (MINLP) to one “Binary Linear Programming” (BLP). This results in a 1000-fold increase in computational efficiency. Benchmarking with commercial software for a real use case, Dr. Liu’s BLP-algorithm finds the global minimum in less than half a second compared to the 15 minutes needed for MINLP by the commercial solver.

## INNOVATION GRANT AND CONTINUED DEVELOPMENT PROJECT FOR EQUINOR

Dr. Liu was awarded an innovation grant from SUBPRO. This was used to further develop and qualify computer code and undertake more extensive testing on use cases provided by Equinor. Such testing on real field cases verified the algorithms and proved the time savings using Dr. Liu’s solutions.

At the time of writing, Dr. Liu is now undertaking a development project for Equinor where code is changed into Python and a stand-alone package shall be delivered to Equinor’s specifications for data input and output content and formats. Dr. Liu is now seeking possible partner(s) with the view to commercialize his innovations.

## SELECTED PUBLICATION

- Haoge Liu, Tor Berge Gjersvik, Audun Faanes. “Subsea field layout optimization (part III) - the location-allocation problem of drilling sites”. Journal of Petroleum Science and Engineering. 2021. <https://doi.org/10.1016/j.petrol.2021.109336>

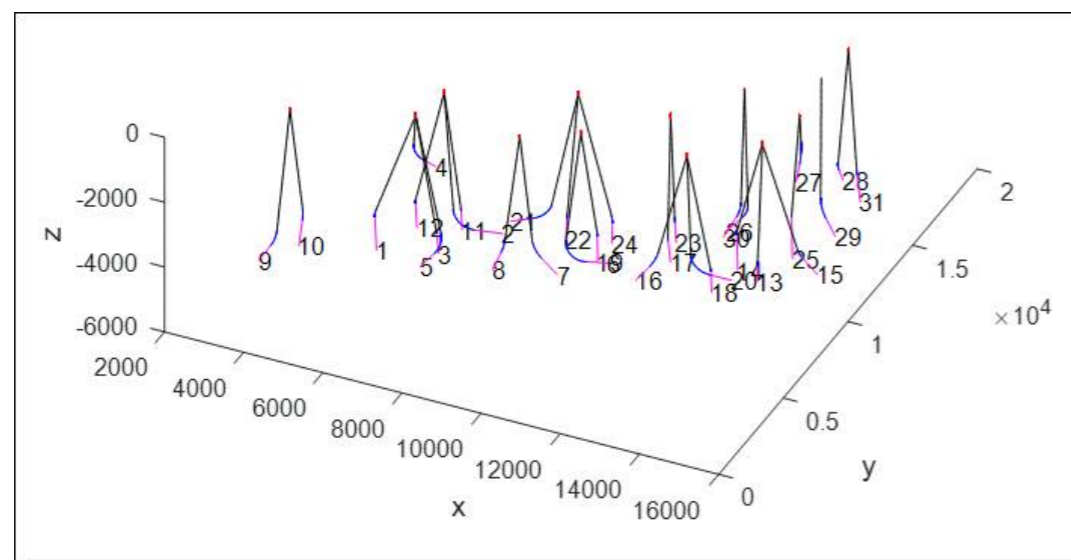

Figure 3: Allocation of wells to templates

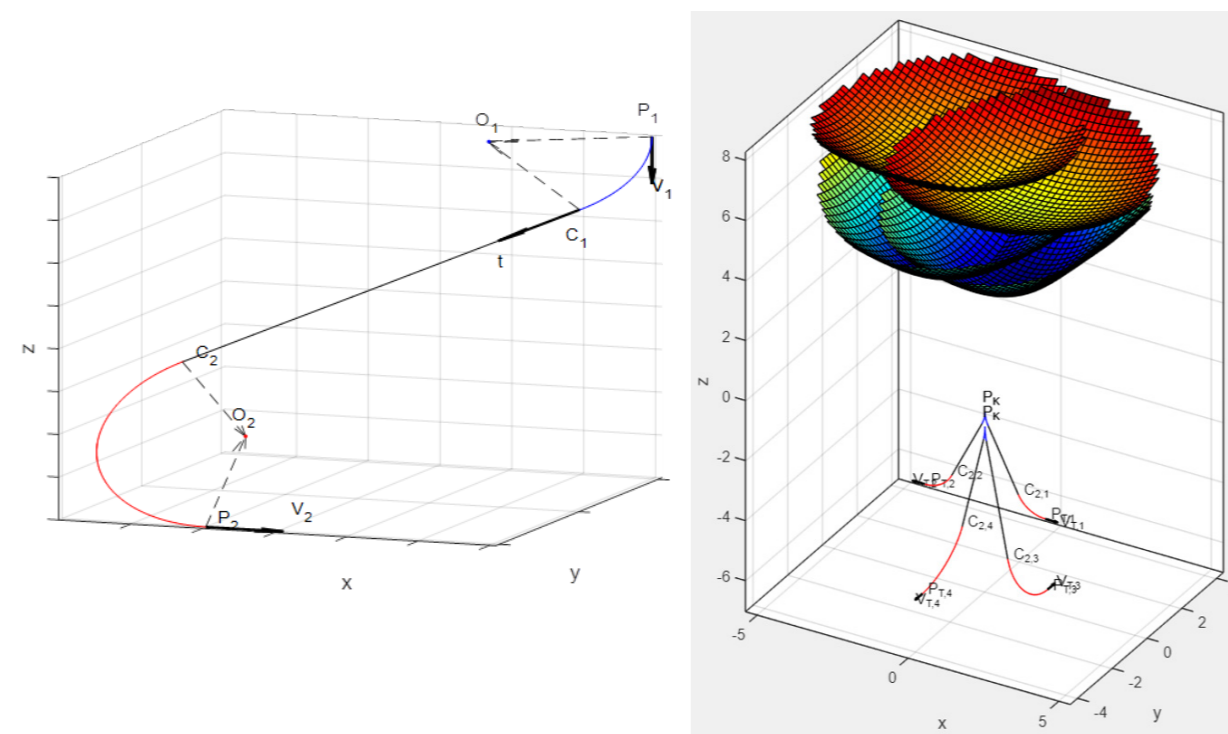

Figure 4: 3D Dubins path



# Enabling technology for low-cost subsea field



Postdoctoral fellow:  
**Lucas C. Sevillano**

## MODULARIZATION OF SUBSEA SYSTEMS

New technologies and novel designs subsea can reduce the amount of marine installation work, and enable the use of smaller, less costly vessels for installation and maintenance operations (Figure 5). Moving some functionalities from the Vertical X-Mas tree (VXT) to the manifold (i.e., choke module, wing valve, etc.); thus extending the barrier envelope to include the manifold and end with the High Pressure Pipeline Protection System (HIPPS), will allow smaller modules to be used while at the same time opening up for changing out for example a barrier valve without having to retrieve the whole VXT – an operation requiring using a full sized and expensive drilling rig.

## SELECTED PUBLICATION

- Sevillano, Lucas; Cantinelli, Sangesland, Sigbjørn; Gjersvik, Tor Berge; Faanes, Audun. "A more accurate approach for the design of subsea chemical storage systems regarding volume requirements of valve leakage tests". 41st International Conference on Ocean, Offshore and Arctic Engineering (OMAE2022); 2022-06-05 - 2022-06-10.

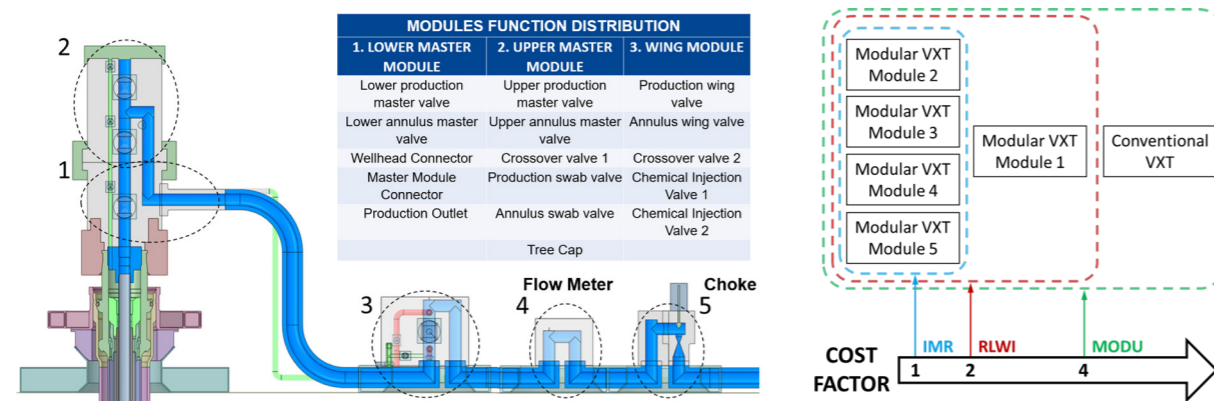

Figure 5. Modular Subsea Production System (SPS) and cost factor for different type of vessels (IMR- Inspection, Maintenance and Repair, RLWI- Riser Less Well Intervention, and MODU- Mobile Offshore Drilling Unit) for installation and replacement of subsea modules

# Valves and materials - design concepts for simplifications



PhD student:  
**Mehman Ahmadli**

## ALTERNATIVE VALVE COATING MATERIALS TO REDUCE ELECTRICAL POWER CONSUMPTION IN VALVE OPERATIONS

Introduction of all-electric subsea systems implies re-design of earlier hydraulic operated components to electric driven components. In this connection the project has studied design options including modelling of barrier valves, alternative coating materials to reduce the friction in the valve mechanism, and simulation of material compatibility due to thermal effects (Figure 6). Material coatings with Wolfram Carbide (WC) and Polycrystalline Diamond Compact (PDC) have been tested in the laboratories at SINTEF. Replacing WC with PDC coating, the tests indicate a reduction in the friction force of the valve by approximately 15%. TotalEnergies has provided valuable background information for the project.

## SELECTED PUBLICATION

- Ahmadli, Mehman; Gjersvik, Tor Berge Stray; Sangesland, Sigbjørn. "Design Assessment and Optimization of a Barrier Valve for Subsea Applications". I: ASME 2023 42nd International Conference on Ocean, Offshore and Arctic Engineering (OMAE 2023); Volume 3 : Materials Technology; Pipelines, Risers, and Subsea Systems. The American Society of Mechanical Engineers (ASME) 2023 ISBN 978-0-7918-8685-4. s. NTNU.

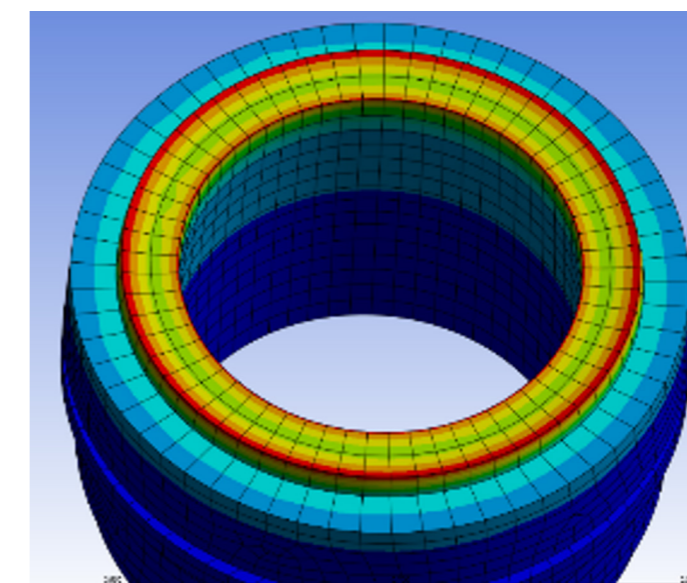

Figure 6 Simulation of material compatibility (stress) due to thermal effects

# Multiphase boosting models



PhD student:  
**Nunez Gilberto**

## SIMPLE MULTIPHASE BOOSTING MODELS TO USE IN INTEGRATED MODELLING OF SUBSEA FIELD SOLUTIONS AND PRODUCTION OPTIMIZATION

Multiphase boosters are often tested in expensive experimental facilities to determine their performance characteristics under realistic fluid and operating conditions. However, this type of data is seldom available during early phases of field development. The main goal of the project was to develop simple multiphase booster models suitable for early phases of field development. Some activities performed in the project (Figure 8) were 1) study of multiphase booster models in commercial software and development of a methodology for technical screening and pre-selection of multiphase helico-axial pumps for subsea boosting systems. 2) creating a model of a wet gas compressor using compressor equations and a homogeneous model, 3) use of computational fluid dynamics (CFD) to generate multiphase flow performance curves for blade cascades with the potential to use them in performance prediction of the complete booster.

## SELECTED PUBLICATIONS

- Nunez, Gilberto; De Andrade, Jesus; Golan, Michael; Sangesland, Sigbjørn. "Modelling the Performance of Subsea Multiphase Boosting". MPUR Europe 2017 (21 September 2017).18
- Nunez, G.; De Andrade, J.; Stanko, M.; Sangesland, S. "Available Technologies and Performance Prediction Models for Multiphase Boosting". ACESS 2016 International conference on advances in subsea engineering, structures & systems; 2016-06-06 - 2016-06-07

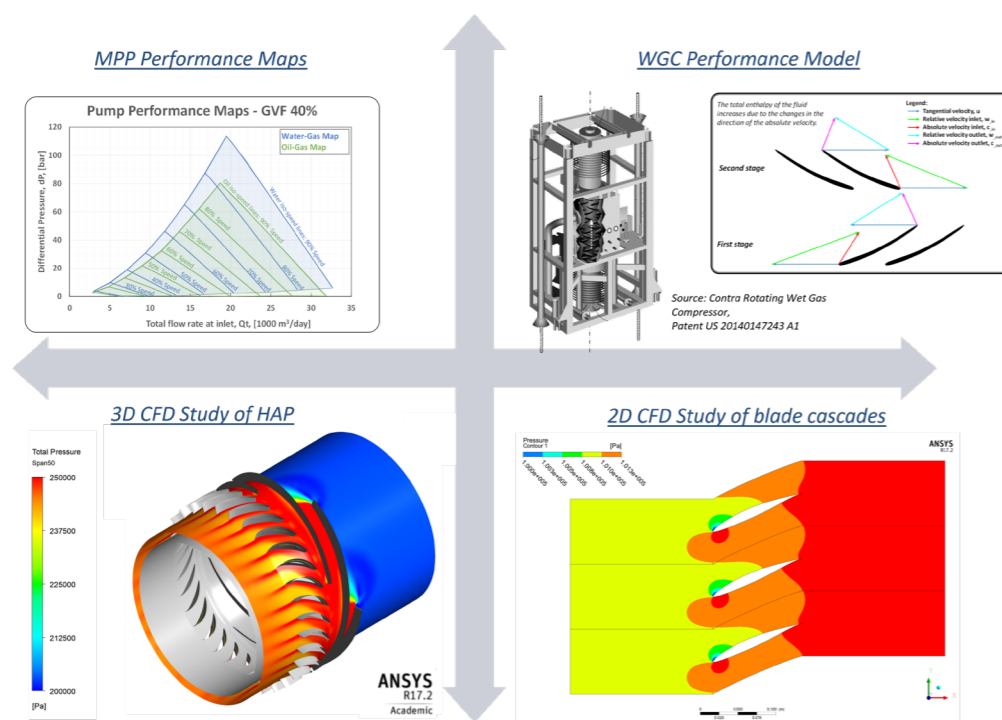

Figure 8 Multiphase boosting – Performance and CFD modelling

# Operation and design of oilfields with power constraints



Researcher:  
**Abraham Parra**

This research project performed a technical feasibility analysis on applying wind power to oil and gas offshore fields. An existing simulation model (from previous works) in the transient process simulator (K-Spice©) from kongsborg Digital was used for the study. The model (Figure 9) had to be improved significantly by adding/modifying the design characteristics of compressors and separators and adding and tuning control elements. The results show that it is possible to vary the produced oil and gas rates through the day to adapt to the variability in power generation of the wind farm. It was also demonstrated that it is possible to keep a constant export of oil and gas by using an export oil tank and pressurizing and depressurizing the export gas pipeline (line-pack).

As a starting point of the project, a literature review was performed on alternative energy generation methods and energy storage methods suitable for powering offshore oil and gas installations. For topside power requirements in the order of 30 MW, the most suitable technologies seem to be wind power for generation and hydrogen for storage.

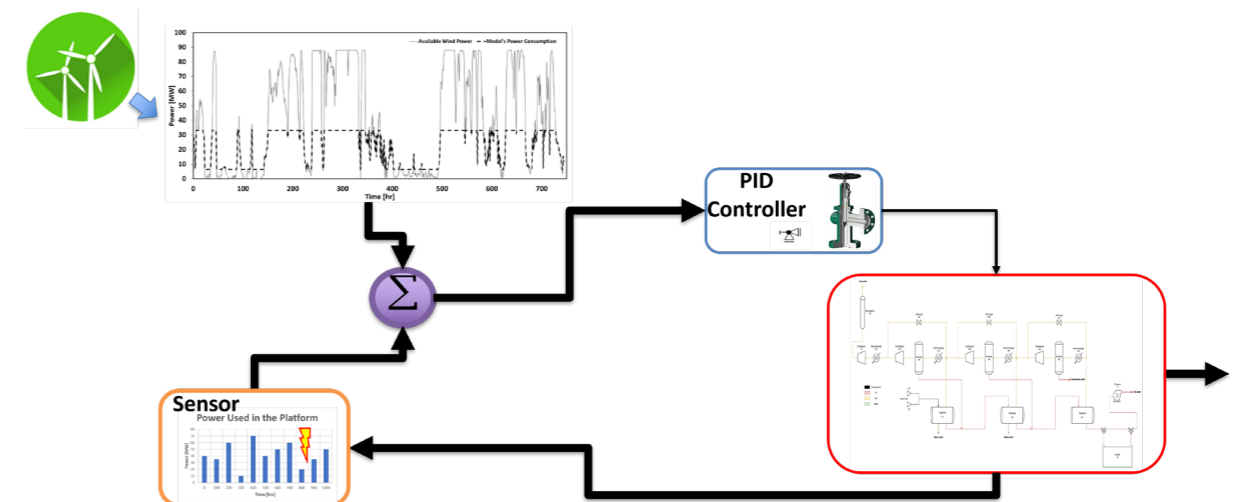

Figure 9 Scheme employed to evaluate varying production rates to adapt to varying power generation using a transient process modeling tool



# CO<sub>2</sub> transport in subsea pipelines



Researcher:  
**Tamires de Souza da Silva**

## SIMPLIFIED CALCULATOR FOR CO<sub>2</sub> TRANSPORT IN SUBSEA PIPELINES

This research project has investigated different one-phase flow models for CO<sub>2</sub> transport in subsea pipelines. A Matlab code has been developed and used for comparison with commercial software. A number of simulations with different seabed topography, pipeline dimensions, etc. have been performed and the simple model shows close agreement with the benchmark software (Olga). (Figure 10). This tool can be used as a simple calculator in an early stage of a field development for transport and injection of CO<sub>2</sub>.

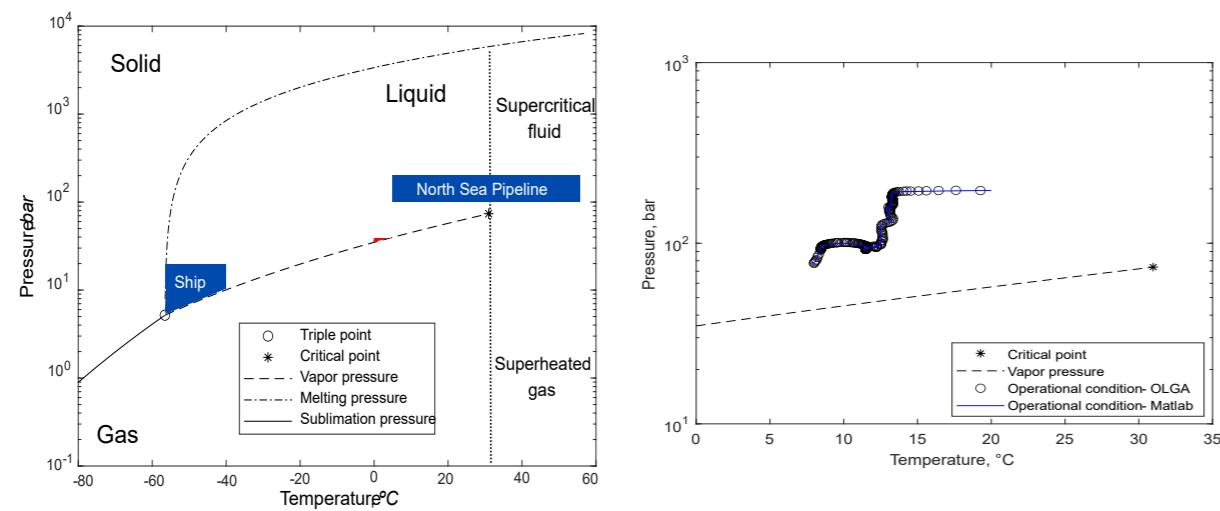
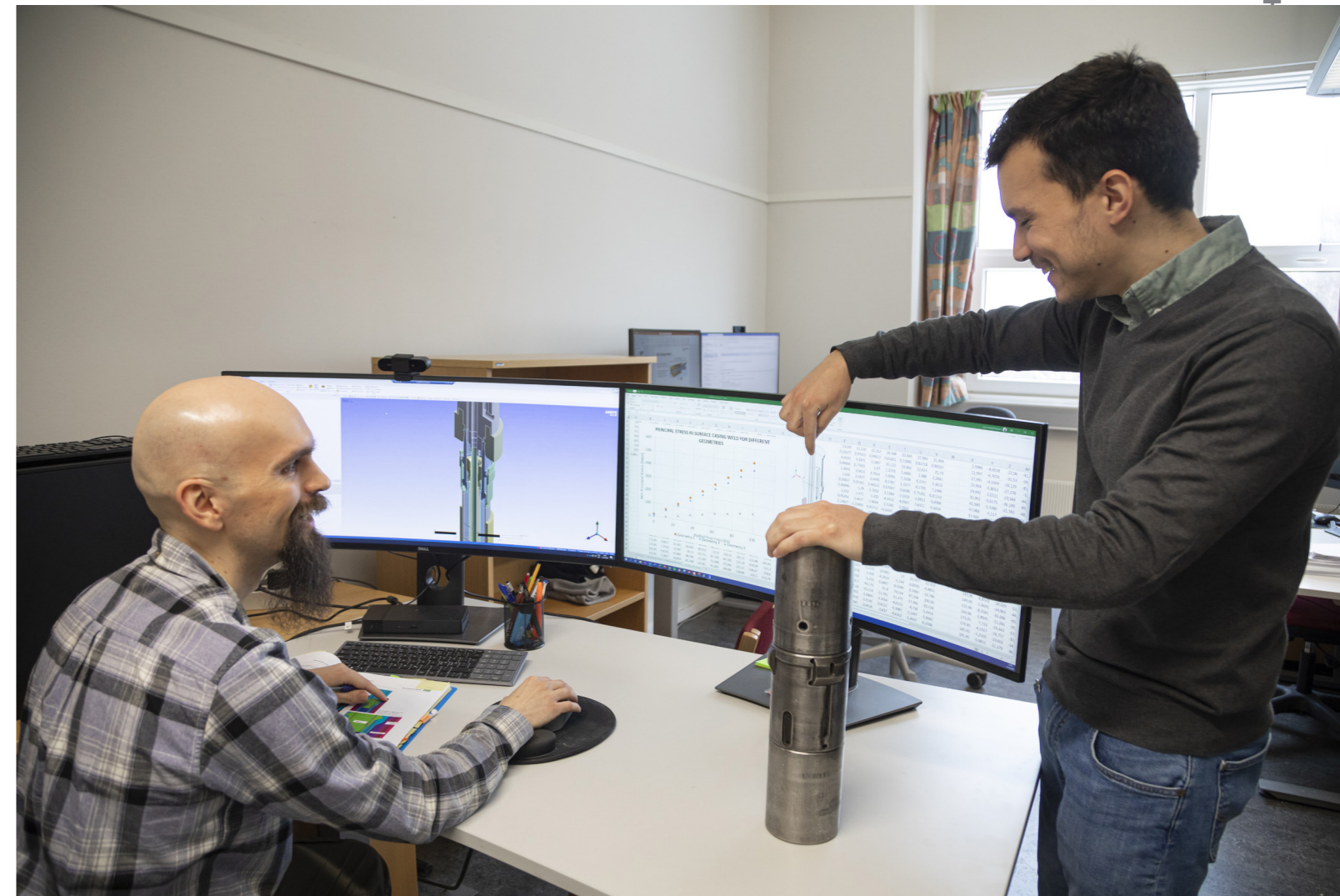

Figure 10 Simulation of pressure drop in CO<sub>2</sub> Trunkline using a simple model vs. benchmark software (Olga).



From the left: Postdoctoral fellow Lucas Cantinelli Sevillano and PhD student Leonardo Sales discussing new methods to develop more efficient subsea fields with lower CO<sub>2</sub> emissions.



RESEARCH AREA

# Reliability, Availability, Maintenance and Safety (RAMS)

Cost efficient solutions without compromising safety and environment.



Professor Mary Ann Lundteigen  
Research Area Manager  
2015-2020  
Department of Engineering Cybernetics, NTNU



Professor Jørn Vatn  
Research Area Manager  
2020-2024  
Department of Mechanical and Industrial Engineering, NTNU

PROJECT MANAGERS AND SUPERVISORS



Professor Jørn Vatn,  
Department of mechanical and industrial Engineering, NTNU



Professor Mary Ann Lundteigen,  
Department of Engineering Cybernetics, NTNU



Prof. Shen Yin,  
Department of mechanical and industrial Engineering, NTNU



Professor Anne Barros,  
Department of mechanical and industrial Engineering, NTNU



Adjunct Professor Gunleiv Skofteland,  
Equinor



Professor Markus Glaser,  
Aalen University



Senior principal Researcher Tore Myhrvold  
(DNV)

SCOPE OF THE RAMS RESEARCH AREA

Subsea developments are mostly based on topside design principles and philosophies. This requires modifications and adaptations where safety demonstration might be demanding since topside proven in use arguments cannot always be used. Focus of subsea projects is on cost efficient solutions tailored for subsea conditions, and with respect to reliability, availability, maintenance, and safety (RAMS) the main perspective is on safety demonstration and production assurance. In particular, we have addressed questions like: i) How can we demonstrate adequate safety of novel technologies? ii) How can we

build confidence about reliability performance in design? iii) How can we reduce maintenance cost and increase reliability by efficient technical health prognostics models, and iv) How can we benefit from machine learning and digital twins for those purposes?

To present a glimpse into the results achieved the following sections present some of the work related to i) health prognostics modelling and ii) safety demonstration.

Project overview

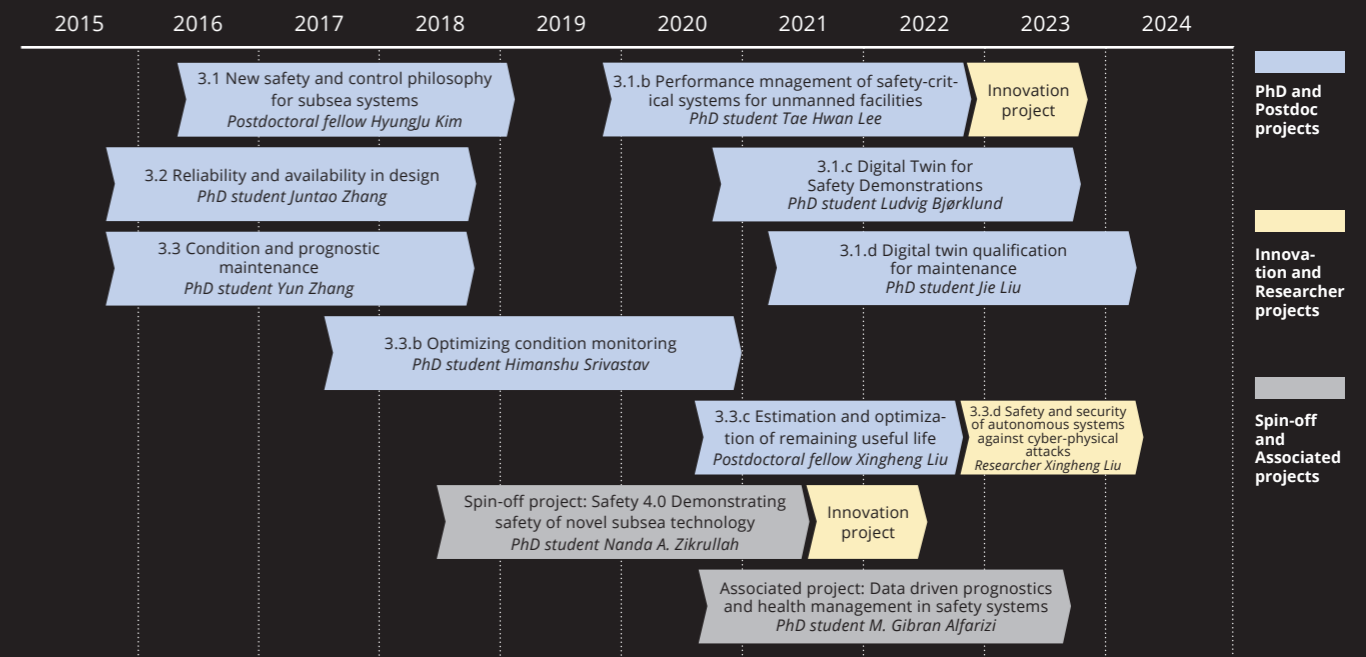

The RAMS team, from the left, around the clock: PhD student Tae Hwan Lee, Professor Jørn Vatn, PhD student Jie Liu, Professor Mary Ann Lundteigen, Researcher Xingheng Liu and associated PhD student Muhammad Gibran Alfarizi.

Professor Shen Yin, Professor Anne Barros - Department of Industrial and Mechanical Engineering, Adjunct Professor Gunleiv Skofteland (Equinor), Professor Markus Glaser (Aalen University) and Senior Principal Researcher Tore Myhrvold (DNV) were not present when the picture was taken.



# Technical health and prognostics modelling



PhD student:  
**Yun Zhang**



Postdoctoral fellow /  
Researcher:  
**Xingheng Liu**



PhD student:  
**Himanshu Srivastav**



PhD student:  
**Jie Liu**

The starting point of maintenance and prognostics modelling in SUBPRO was the project by **PhD student Yun Zhang** (2015-2018) resulting in the thesis "Condition-Based Maintenance Models: Application to Subsea Safety Systems". The main objective was to develop suitable condition-based maintenance (CBM) models for some typical safety systems in subsea. In the first part of the research CBM models for single-unit systems were developed with specific subsea challenges. In particular a delayed maintenance model of a choke valve was developed. The degradation was characterised by a stochastic gamma process where the health indicator of erosion is the difference between the theoretical and estimated valve flow coefficients (Cv).

The common belief is that the erosion of a production choke is monotonic and irreversible. This has been the basis for the gamma process modelling by Yun. However, the historical raw Cv deviation health indicator shows a non-monotonic behaviour. A second project titled "Estimation and optimization of remaining useful life" awarded to **Postdoc Xingheng Liu** (2020-2022) aimed to address this challenge.

In this project it was established that the Cv parameter was influenced not only by the condition of the valve but also by the variable opening position of the valve, and it was assumed that this was the cause of the non-monotonic trend in the raw measured Cv data. By correcting the raw measured Cv values for the contribution from the variable valve opening, the resulting corrected data showed

a monotonic trend, as illustrated in Figure 1 above. Hence, the corrected Cv data appears to provide a better input to the model for the remaining useful life than the raw measured Cv data.

Most of the models during this project have been implemented in a suit of Python scripts with an associated user guide. A webinar was arranged to present the prototype for the SUBPRO partners.

In relation to prognostics modelling the project by **PhD student Himanshu Srivastav** (2017 -2021) is worth mentioning. The thesis title is "Optimizing condition monitoring for dynamic health and risk management". One aspect of this work was to investigate the negative impact of proof-testing. This is typical for safety devices where proof-tests are used to reveal hidden failures or hidden degradation states. Frequent testing is reducing the portion of time a degraded or fault state is unknown but at the cost of extra degradation to the safety device. In the basic model a binary situation was considered, but later the research was extended to a multi-state degradation model applied to a subsea compressor system. This work was conducted together with the System control research area. This is one of many examples of cross discipline collaboration between the research areas of SUBPRO.

Mathematical models developed to support maintenance decisions will hardly be used if they are operated as stand-alone tools. Therefore, these models need to be connected to the physical asset, i.e., there is need for so-called digital twins. A qualification framework for such twins is also important and in **PhD student Jie Liu's** project (2021-2024) such a framework is developed and piloted on maintenance models from the RAMS-lab at NTNU.

## SELECTED PUBLICATIONS

- Srivastav, Himanshu; Barros, Anne; Lundteigen, Mary Ann.  
"Introduction of degradation modeling in qualification of the novel subsea technology".  
Reliability Engineering & System Safety. 2021; 216:  
doi.org/10.1016/j.res.2021.107956
- Liu X., J. Matias, J. Jäschke, J. Vatn.  
"Gibbs sampler for noisy Transformed Gamma process: Inference and remaining useful life estimation".  
Reliability Engineering & System Safety, 2022: 217,  
doi.org/10.1016/j.res.2021.108084

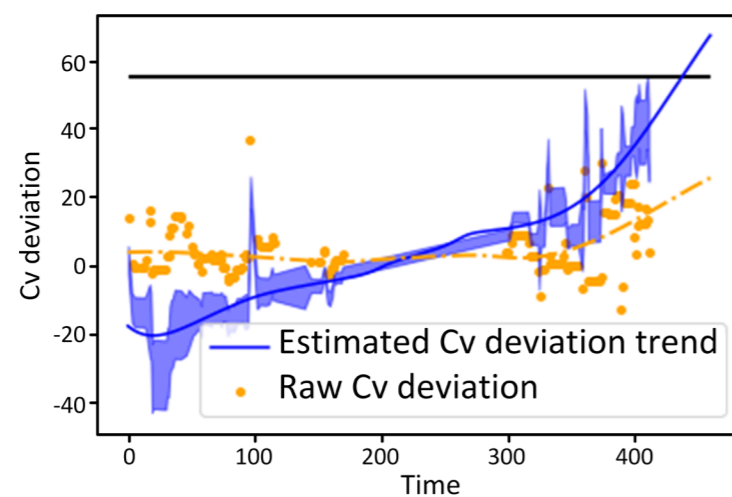

Figure 1 The adjusted and raw Cv deviation

# Demonstrating safety of novel technologies in complex operations



Postdoctoral fellow:  
**Hyungju Kim**



PhD student:  
**Juntao Zhang**



PhD student:  
**Nanda Zikrullah**



PhD student:  
**Ludvig Bjørklund**



PhD student:  
**Tae Hwan Lee**



Postdoctoral fellow /  
Researcher:  
**Xingheng Liu**

The research in this area was motivated by how new technology can be safely introduced and demonstrated for subsea and unmanned operation. Many of the current rules and practices are based on traditional manned installations that may not be optimal in new operational contexts and its risks.

The project on **new safety and control philosophy for subsea systems (2015-2018)** with **Postdoc Hyungju Kim** involved an extensive mapping of regulations, standards, and guidelines applied to current subsea safety systems and their anchoring in topside facility practices and requirements. SUBPRO Industry partners were able to share some experiences from recently installed subsea production and processing facilities, providing some practical examples of implemented solutions. The main contribution was the utilization of the systems theoretic process analysis (STPA) applied in other domains like maritime, aviation, and space systems to identify requirements for safety functions anchored in subsea-specific hazardous and mal-operation scenarios.

The **project on reliability and availability assessment of novel subsea technologies (2015-2018)** with **PhD student Juntao Zhang** developed an approach, named STPA-RAM, where STPA could be combined with quantitative simulation-based methods for availability studies.

The two aforementioned projects identified a need for new industry practices for qualification of novel subsea design concepts for safety systems. The spinoff project Safety 4.0 led by DNV (see separate article) involved a new **project on demonstrating functional safety of novel**

**subsea technologies (2018-2022)** with **PhD student Nanda Zikrullah**. His results were integrated in a text-book published by DNV. The book is being used by master students and in a continuing education course.

The research in Safety 4.0 gain interests outside Norway, for example the high-integrity mechatronic systems group at Aalen University in Germany. Professor Markus Glaser, leading the group, had a research stay with SUBPRO in 2019-2020. During this period, we identified and got funding for a new **project on safety demonstration of all-electric subsea valves using digital twins (2020-2024)** with **PhD student Ludvig Bjørklund**. The main contribution has been a framework for how the digital twins are systematically integrated in different stages of developments to test the control system. The application has focused on the battery management system of a subsea all-electric safety valve shown in Figure 2. The digital twin representation ranges from high-level functions to interfaces and implementation onto field programmable gate arrays (FPGAs).

The project on **performance management of safety critical systems for unmanned facilities (2019-2024)** with **PhD student Tae Hwan Lee** has focused on developing a decision-support system for safety instrumented systems (SIS,) called SIS advisor shown in Figure 3, using machine learning (ML). The simulation tool K-Spice from Kongsberg Digital has been used to complement the training of the model to create data for unlikely hazardous scenarios. The main contributions relate to how to manage the datasets in the training process and the choice of a suitable performance measure.

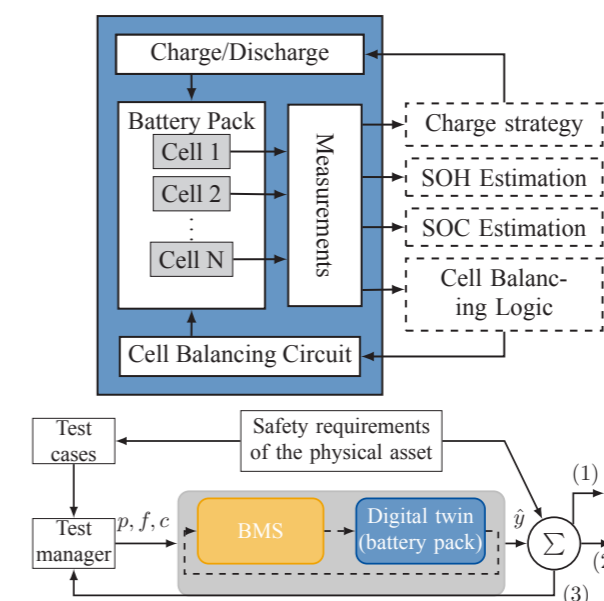

Figure 2. Testing the battery management system using digital twin

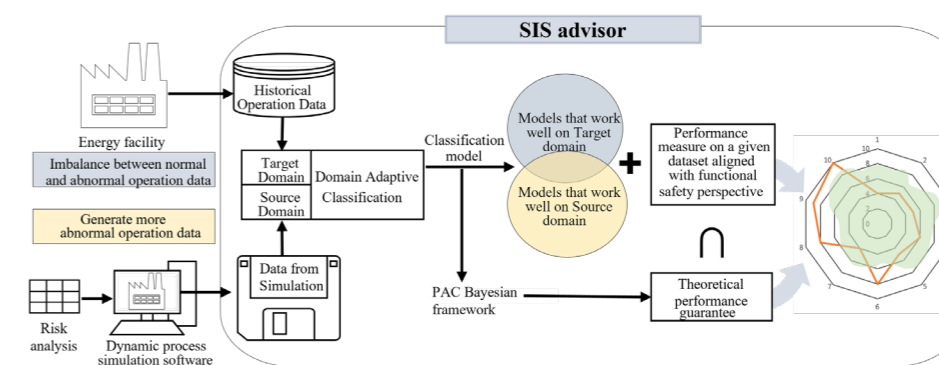

Figure 3. Overview of the SIS advisor framework

The project **Safety and security of autonomous systems against cyber physical attacks (2022-0223)** by **researcher Xingheng Liu** has explored safety and security aspects of operation and maintenance of equipment in the Autonomous Vehicles Research Studio at NTNU.

## SELECTED PUBLICATIONS

- Bjørklund, Ludvig Jonathan; Schick, Johannes; Lundteigen, Mary Ann; Glaser, Markus. "Towards digital twins for safety demonstrations: Interfacing strategies for FPGA-targeted applications". Computers & industrial engineering- (2023) <https://doi.org/10.1016/j.cie.2023.109733>
- Kim H, Lundteigen MA, Hafver A, Pedersen FB. "Utilization of risk priority number to systems-theoretic process analysis: A practical solution to manage a large number of unsafe control actions and loss scenarios". Proceedings of the Institution of Mechanical Engineers, Part O: Journal of Risk and Reliability. 2021;235(1):92-107. doi.org/10.1177/1748006X20939717
- Zhang J, Kim H, Liu Y, Lundteigen MA. "Combining system-theoretic process analysis and availability assessment: A subsea case study".

Proceedings of the Institution of Mechanical Engineers, Part O: Journal of Risk and Reliability. 2019;233(4):520-536. doi.org/10.1177/1748006X18822224

- Zikrullah NA, Kim H, van der Meulen MJ, Skofteland G, Lundteigen MA. "A comparison of hazard analysis methods capability for safety requirements generation". Proceedings of the Institution of Mechanical Engineers, Part O: Journal of Risk and Reliability. 2021;235(6):1132-1153. doi.org/10.1177/1748006X211003463
- Tae Hwan Lee, Gunleiv Skofteland, Mary Ann Lundteigen. "Performance Management of Safety Instrumented Systems for Unmanned Facilities Using Machine Learning: Decision Support System for SIS". In Proceedings of the 31st European Safety and Reliability Conference. 2021. doi.org/10.3850/978-981-18-2016-8\_259-cd
- Liu, Xingheng; Yin, Shen; Liu, Jie; Vatn, Jørn; Bni, Asmae. "Exploring security challenges in enhancing Digital Twins capabilities with ChatGPT". 2023 International Congress on Industrial and Applied Mathematics; 2023-08-20 - 2023-08-25.



# Industry collaboration and impacts

Beyond the scheduled SUBPRO workshops and 1:1 partner meetings, the RAMS area contributed to organizing three full-day seminars: one in 2016, hosted by ABB; one in 2019, hosted by DNV; and one in 2020 as a webinar due to COVID-19. The workshops addressed, for example, regulatory and technology gaps for safety systems on unmanned facilities and the use of digital twins for improved control, condition monitoring, and safety. Results from one of the workshops resulted in a conference paper (doi: 10.3850/978-981-18-2016-8\_246-cd).

DNV who collaborated with the RAMS area throughout the whole SUBPRO period made the following statement during the SUBPRO final symposium: *"For DNV the most valuable outcome from SUBPRO, has been the Safety 4.0 IPN spin-off project which we initiated together with Mary Ann Lundteigen. The PhD student, Nanda Zikrullah, is now working for DNV. Our CEO turned to us and the Safety 4.0 project, to initiate DNV's recommended practice for AI which was published in November."*

*Test rig for condition monitoring of rotating equipment, used in PhD student Jie Liu's Master project, prior to the PhD project.*

*From the left: PhD student Jie Liu, Postdoctoral fellow/Researcher Xingheng Liu and PhD student Tae Hwan Lie*

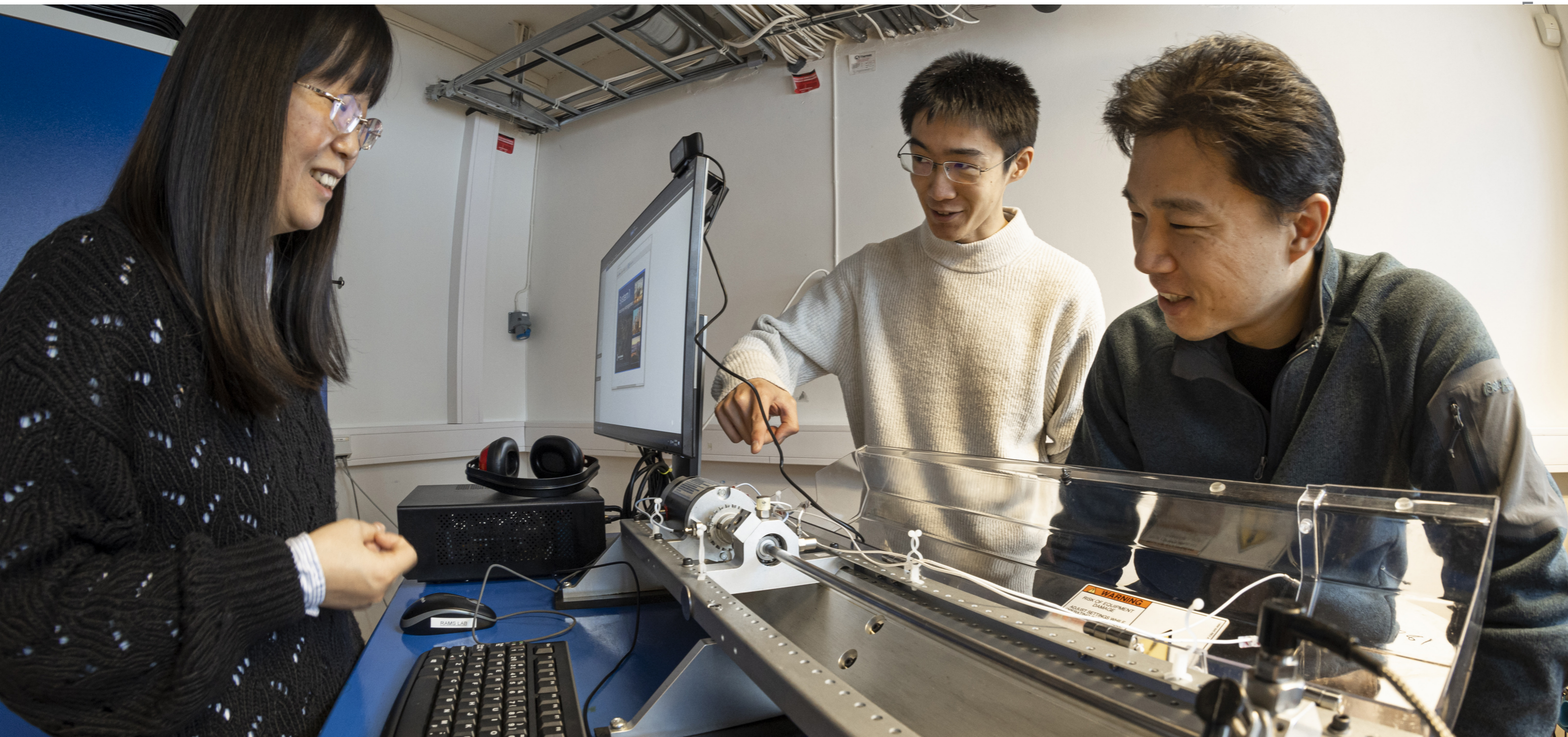



RESEARCH AREA

# Separation - Fluid characterization

8 years of fluid characterization in SUBPRO, implications for subsea production and processing



**Professor Gisle Øye**  
Research Area Manager  
Department of Chemical Engineering

## PROJECT MANAGERS AND SUPERVISORS



Professor Johan Sjøblom,  
Department of Chemical Engineering,  
NTNU



Assoc. Prof. Brian A. Grimes,  
Department of Chemical Engineering,  
NTNU

### SCOPE OF THE RESEARCH AREA SEPARATION - FLUID CHARACTERIZATION

Successful subsea installations require high efficiency and minimal maintenance of the processing equipment. This means that the behavior of the fluids must be well understood. Efficient separation of gas, oil and water and reliable transport of the hydrocarbons are central for optimization of subsea processes. Since the behavior of the fluids is strongly linked to their chemical composition, it is essential with proper fluid characterization that provides fundamental understanding of the microscopic phenomena, like attachment of oil drops to gas bubbles and precipitation of wax crystals. This knowledge can lead to more efficient separation and transport processes.

The major topic in this research area has been experimental studies of produced water treatment and reinjection (4 PhD and 2 post.doc projects). In addition, coalescence and separation models have been studied theoretically (1 PhD and 1 post.doc project), and wax formation/flow assurance has been investigated experimentally (2 PhD projects).

## Project overview

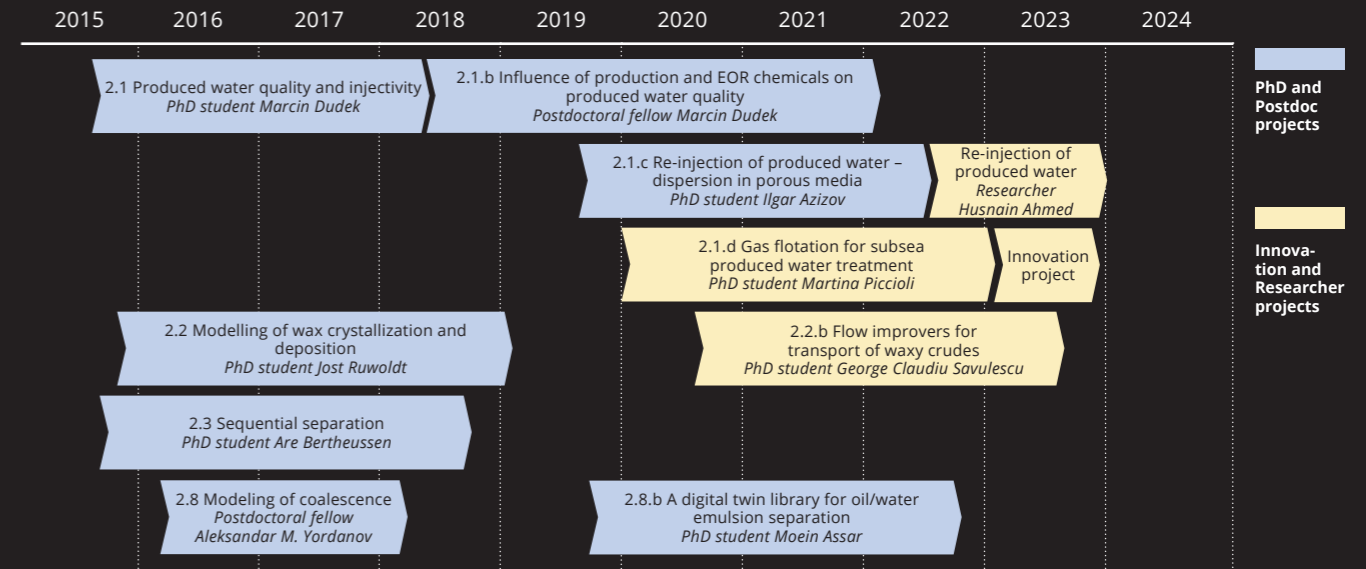

**The Fluid Characterization team:**

From the left: PhD student Moein Assar, Dr. Sebastien Charles Simon, Professor Gisle Øye, PhD student George Claudiu Savulescu and PhD student Ilgar Azizov.

Professor Johan Sjøblom and Associate Professor Brian A. Grimes were not present when the picture was taken.



# Subsea produced water management

## Subsea separation and gas flotation



PhD student:  
**Martina Piccoli**



PhD student:  
**Are Berheussen**

The large amounts of produced water can bottleneck the petroleum production process. Subsea separation and treatment of the produced water (i.e. processing closer to the well) can mitigate the issue by reducing the volume of fluids pumped to the platform for processing, and thereby reducing CO<sub>2</sub> emissions. Moreover, the separation of the produced fluids should be easier at the high pressure and temperature conditions available at short distance from the wellhead.

With respect to produced water treatment, we have particularly focused on gas flotation as a potential treatment method at subsea conditions. The process has been studied both macroscopically, in a gas flotation setup run at elevated pressure and temperature, and microscopically (Figure 1A), by developing novel microfluidic techniques (Figure 1B) to follow attachment of oil drops to gas bubbles (Figure 1C) and coalescence of oil drops and gas bubbles (Figure 1D) in detail. Promoting these microscopic phenomena are essential for achieving good oil removal efficiency in gas flotation units.

The most important knowledge about the treatment of produced water fluids that was gained in SUBPRO can be summarized as follows:

- pH determines the amount and type of acidic and basic oil components that partition into the water phase (Bertheussen et al. 2017).
- It has been demonstrated microscopically that dissolved organic components in the water phase adsorb onto gas bubbles and slow down bubble-bubble coalescence and drop-bubble attachment (Dudek et al. 2018).
- It has been demonstrated microscopically that increased temperature enhances bubble-bubble coalescence and drop-bubble attachment (Piccoli et al. 2023).
- The trends for macroscopic oil removal by gas flotation was the same as observed microscopically, which confirmed the scalability of the microscopic observations (Piccoli et al.)

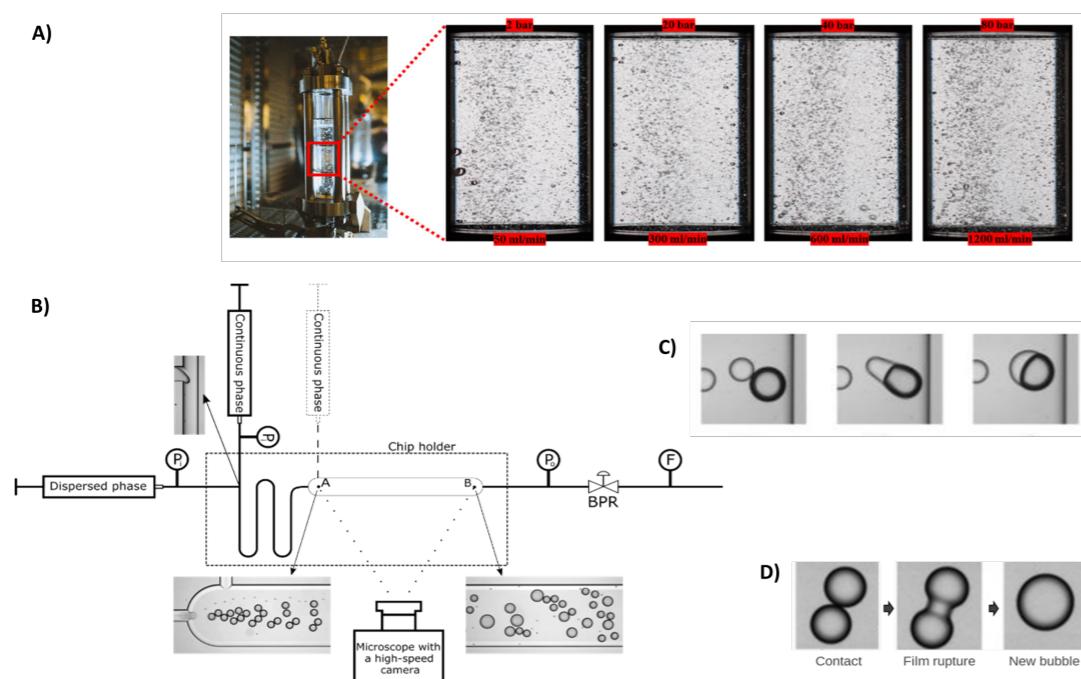

Figure 1: A) Image of gas flotation column with gas bubbles formed at different pressures, B) design of microfluidic chip for following coalescence and drop-bubble attachments, C) attachment of an oil drop to a gas bubble, and D) coalescence of two bubbles. Both types of studies can be carried out up to 80°C and 80 bar.

## Re-injection of produced water



PhD student / Postdoctoral fellow:  
**Marcin Dudek**



PhD student:  
**Ilgar Azizov**



Researcher:  
**Husnain Ahmed**

Re-injection of produced water was another topic considered in this research area. This process is environmentally attractive as it limits the need for discharging the produced water into the sea. However, a major limitation for implementation of produced water re-injection is often the risk of uncontrolled permeability decline of a formation due to clogging by particles and droplets present in the water. In SUBPRO we established a microfluidic methodology for visually following the transport and retention of dispersed oil and particles in porous media, improving the understanding of clogging mechanisms (Azizov et al. 2022). It was for example demonstrated that the presence of small amounts of surfactants (i.e. remains of production chemicals) in the water phase had huge influence on how solid particles were retained in the porous medium (Figure 2)

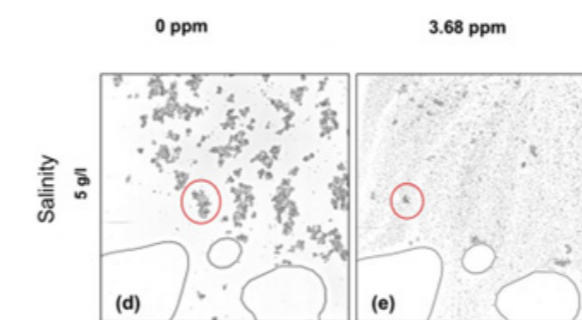

Figure 2: Silica particles retained as aggregates in the porous medium (left) and silica particles after exposure to small amounts of surfactant (i.e. simulating production chemicals) retained primarily as single particles in the porous medium (right).

### SELECTED PUBLICATIONS

- Azizov, M. Dudek, G. Øye. "Studying droplet retention in porous media by novel microfluidic methods". *Chemical Engineering Science*, 248, 117152 (2022). <https://doi.org/10.1016/j.ces.2021.117152>
- M. Dudek, G. Øye. "Microfluidic Study on the Attachment of Crude Oil Droplets to Gas Bubbles". *Energy & Fuels* 32(10): 10513-10521. (2018). <https://doi.org/10.1021/acs.energyfuels.8b02236>
- M. Piccoli, R. A. G. Larsen, M. Dudek, S. V. Aanesen, G. Øye. "Combined Influence of High Pressure and High Temperature on the Removal of Crude Oil from Water during Laboratory-Scale Gas Flotation". *Energy Fuels* 2023, 37, 5644–5651. (2023). <https://doi.org/10.1021/acs.energyfuels.2c04058>
- M. Piccoli, D. Kouranou, M. Dudek, G. Øye. "The effect of temperature and dissolved organic components on the film thinning between droplets and bubbles". (submitted 2024)
- Bertheussen, S. Simon, j. Sjøblom. "Equilibrium partitioning of naphthenic acids and bases and their consequences on interfacial properties". *Colloids and Surfaces A: Physicochemical and Engineering Aspects*, 529, 45-56. (2017). <https://doi.org/10.1016/j.colsurfa.2017.05.068>

# Flow assurance



PhD student:  
**Just Ruwolt**



PhD student:  
**George-Claudiu Savulescu**

Subsea production and processing often involve transport of crude oil at low temperatures. Challenges can emerge due to paraffin wax in the crude oil, as cold temperatures induce wax crystallization and precipitation. This can further lead to decreased productivity, issues during pipeline restart, and even pipeline blockage. Prevention of wax crystallization and precipitation and remediation therefore plays an important role in flow assurance. In SUBPRO the goal was to improve understanding of wax crystallization and precipitation, as well as the mechanisms of wax inhibitors to facilitate the management and prevention of wax related issues. In particular new NMR (Nuclear magnetic resonance) and AFM (Atomic force microscopy) methods (Figure 3) were developed to obtain this (Ruwoldt et al. 2019, Savulescu et al. 2023). It was demonstrated that both indigenous crude oil components (i.e. asphaltenes) and added pour point depressants influenced both the crystallization rate and crystal structure of the precipitated wax (Figure 4).

### SELECTED PUBLICATIONS

- Ruwoldt, J., Humborstad Sørland, G., Simon, S., Oschmann, H., & Sjöblom, J. "Inhibitor wax interactions and PPD effect on wax crystallization: New approaches for GC/MS and NMR, and comparison with DSC, CPM, and rheometry". Journal of Petroleum Science and Engineering, 177, 53-68. (2019). <https://doi.org/10.1016/j.petrol.2019.02.046>
- G. C. Savulescu, S. Simon, G. Sørland, G. Øye. "Novel NMR techniques to assess the wax precipitation evolution in crude oil systems". Energy & Fuels, 37 (1), 291-300. (2023). <https://doi.org/10.1021/acs.energyfuels.2c03309>

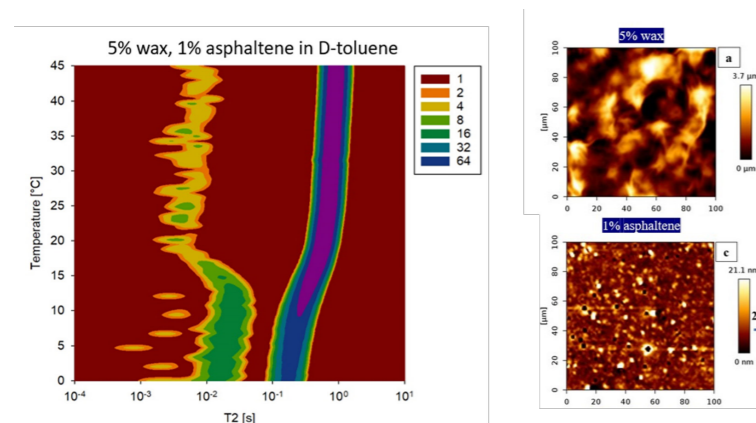

Figure 3: Left: Low-field NMR map of co-precipitation of asphaltenes and wax and right: AFM images of deposited wax (top) and asphaltenes (bottom).

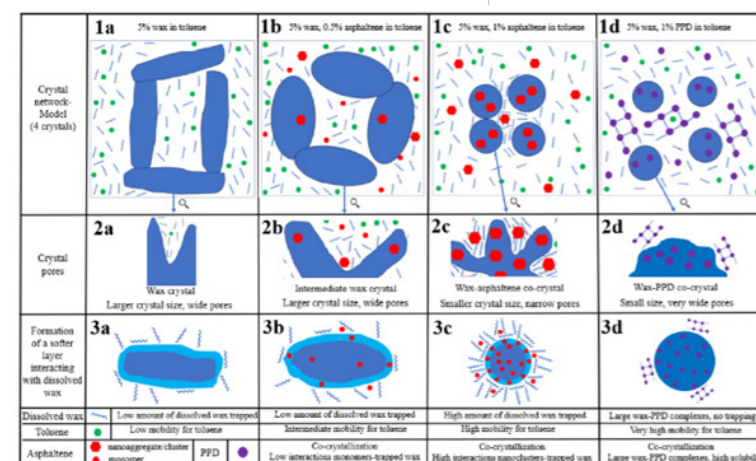

Figure 4: Model schematics for crystal networks and liquid phases for wax and wax-asphaltene systems at 0 °C.

# Separation model



Postdoctoral fellow:  
**Aleksander Yordanov**



PhD student:  
**Moein Assar**

The development of fundamentally advanced yet simply implemented models for the separation and transport of multiphase fluids is a valuable tool for process and system engineers tasked with developing, controlling, and optimizing new subsea transport and separation processes. For processes involving crude oil/water emulsions, a C++ model library for fast and robust computation of PBMs (Population balance models) with various complexities has been developed. Based on the level of sophistication and the external dimensions involved, three distinct modules are envisaged for simulating different applications (Figure 5). The model was applied in oil-water separation studies (Assar et al. 2023)

### SELECTED PUBLICATIONS

- M. Assar, S. Simon, G. Sørland, G., B. A. Grimes. "A theoretical and experimental investigation of batch oil-water gravity separation". Chemical engineering research & design; 194; 136-150. (2023). <https://doi.org/10.1016/j.cherd.2023.04.029>
- A.Y. Mehandszhiyski, B. A. Grimes. "Calculation of the probability for ionic association and dissociation reactions by molecular dynamics and umbrella sampling". Molecular Physics, Volume 114, 2016-Issue 11. (2016). <https://doi.org/10.1080/00268976.2016.1155776>

Aleksandar Yordanov developed a non-equilibrium molecular dynamics simulation for the disjoining pressure between coalescing droplets as a function of surfactant concentration after completing his PhD on the subject of naphthenic acid - calcium precipitation chemistry.

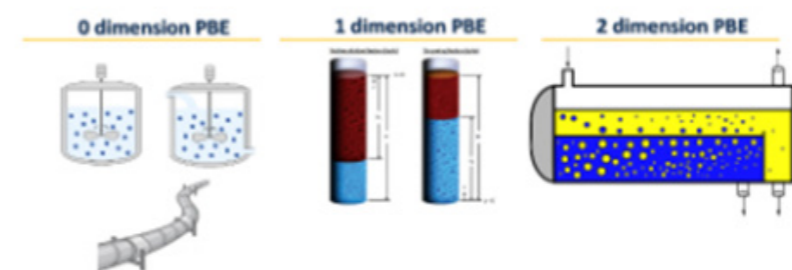

Figure 5: 0, 1 & 2 dimensional PBE (population balance equations) applications



## Industrial involvement in the research area as a whole

Beyond reference group meetings with the industrial partners, two of the PhD projects have had co-supervisors from Equinor (Svein Viggo Aanesen and Audun Faanes). In addition, we have had several individual meetings with AkerSolutions in the gas flotation projects. This has resulted in several joint publications with partners.

*PhD student/Postdoctoral fellow Marcin Dudek engaged in a micro-fluid experiment.*





RESEARCH AREA

# Separation - Process concepts

The aim of the research area Separation – Process Concepts is to develop fundamental knowledge and technical solutions for subsea separation and fluid treatment, to meet pipeline specifications and enabling direct delivery of fluids to pipelines or local storage.



**Professor Hugo Atle Jakobsen**  
Research Area Manager  
Department of Chemical Engineering, NTNU



Professor Hugo Jakobsen, Department of Chemical Engineering, NTNU  
 Professor Liyuan Deng, Department of Chemical Engineering, NTNU  
 Professor Magne Hillestad, Department of Chemical Engineering, NTNU  
 Professor Hanna Knuutila, Department of Chemical Engineering, NTNU  
 Associate Prof. Milan Stanko, Department of Geoscience and Petroleum and Department of Chemical Engineering, NTNU  
 Dr. Eivind Johannessen, Equinor

**SCOPE OF THE RESEARCH AREA SEPARATION –PROCESS CONCEPTS**

The research comprises the following processing tasks:

- Natural gas dehydration and hydrogen sulphide removal
- Subsea production of low carbon hydrogen
- Fluid particle separation
- Compact Oil/water separation

**Project overview**

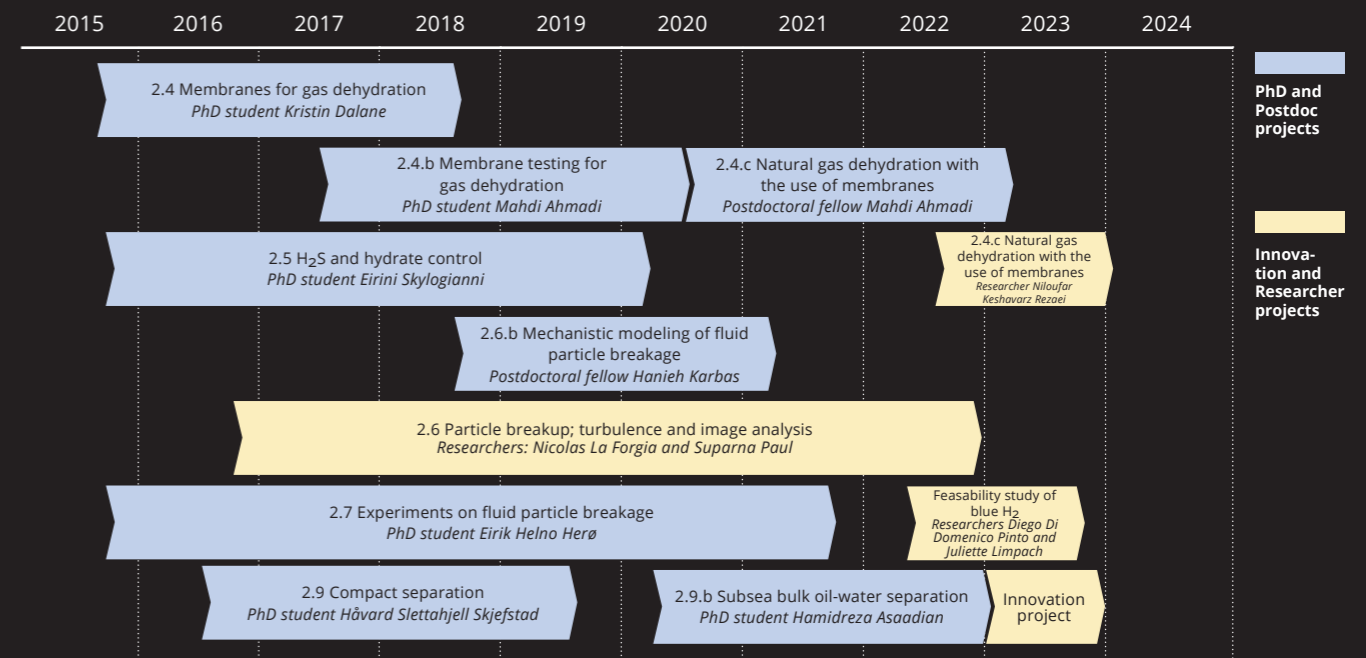

This figure shows an overview of all projects within the research area.



**The Separation – Process concepts team.** From the left: PhD student Hamidreza Asaadian, Postdoctoral fellow Mahdi Ahmadi, Researcher Nicolas La Forgia, Associate Professor Milan Stanko, Professor Hugo Jakobsen.

Professor Magne Hillestad, Professor Liyuan Deng, Professor Hanna Knuutila, and Dr. Eivind Johannessen were not present when the picture was taken.



# Combined hydrogen sulphide removal and hydrate control by blend of monethylene glycol (MEG) and methyldiethanolamine (MDEA)



PhD student:  
**Eirini Skylogianni**

During natural gas treatment, CO<sub>2</sub> and H<sub>2</sub>S, and water are removed to avoid hydrate formation, to meet the pipeline specifications, and environmental requirements. Non-regenerative chemicals, so called scavengers, are commonly used to remove H<sub>2</sub>S from natural gas. However, their transportation, use is not ideal for fields far from the shore and they cannot treat high H<sub>2</sub>S concentrations. Further, oil and gas fields experience increased sulfur content due to Enhanced Oil Recovery. This project aimed to substitute the scavengers by a single regenerable solvent blend to control both H<sub>2</sub>S and water content simultaneously in a subsea process. Various experimental studies were conducted.

## MAIN RESULTS

The experiments showed that the proposed solvent could simultaneously remove H<sub>2</sub>S and water. The project also demonstrated that although CO<sub>2</sub> does not react with pure MEG, it does react with MEG in the presence of MDEA due to MEG autoprotolysis.

## SELECTED PUBLICATION

- Skylogianni, E., Mundal, I., Pinto, DDD., Coquelet, C., Knuutila, HK.  
*"Hydrogen sulfide solubility in 50 wt% and 70 wt% aqueous methyldiethanolamine at temperatures from 283 to 393 K and total pressures from 500 to 10000 kPa"*.  
Fluid Phase Equilibria, Volume 511, 2020, 112498.  
<https://doi.org/10.1016/j.fluid.2020.112498>

# Feasibility study of offshore production of low carbon H<sub>2</sub>



Researcher:  
**Diego Di Domenico Pinto**



Researcher:  
**Juliette Limpach**

H<sub>2</sub> is acknowledged to play a role in the energy transition. Steam-methane reforming (SMR) is state-of-the-art technology for H<sub>2</sub> production where natural gas is reacted with steam at high temperature and pressure, producing H<sub>2</sub> and CO<sub>2</sub>. This project studied the technological and financial opportunities of combining SMR with CO<sub>2</sub> capture at an offshore production plant. If located near a reservoir where CO<sub>2</sub> can be reinjected, CO<sub>2</sub> transportation costs could be reduced compared to onshore CCS.

Simulation and cost estimation studies performed investigated the optimal configuration of CO<sub>2</sub> capture using different solvent-based CO<sub>2</sub> capture technologies, and oxy-fuel-based hydrogen production.

## MAIN RESULTS

Heat integration was essential for all cases. SMR is a steam exporting process, and the steam could be redirected to the needs of the carbon capture plant, reducing the need for additional heat. The results showed that high CO<sub>2</sub> capture rates can reduce the carbon intensity of the process while keeping the production cost low.

## SELECTED PUBLICATION

- Pinto, DDD., Limpach, JM., Knuutila, HK.  
*"Simulation-based assessment of the potential of offshore blue hydrogen production with high CO<sub>2</sub> capture rates with optimized heat recovery"*.  
Gas Science and Engineering, Volume 121, 2024, 205177.  
<https://doi.org/10.1016/j.jgsce.2023.205177>

# Fundamental investigation of single fluid particle breakage phenomena for efficient phase separation



PhD student:  
**Eirik Helno Herø**



Researcher:  
**Nicolás La Forgia**



Researcher:  
**Suparna Paul**



Postdoctoral fellow:  
**Hanieh Karbas**

Knowledge on fluid particle size distribution in turbulent flows is essential for enabling efficient phase separation (large particles are easier to separate than small particles). When the fluid passes locations with high turbulence, large particles may break into smaller particles, causing adverse effects on the separation efficiency. The project has studied the mechanisms of such particle breakage. Potential applications of the novel knowledge are related to produced water treatment, gravity separators, scrubbers, other separator designs and pipeline flow assurance.

A novel experimental rig was designed and built at NTNU, as sketched in Figure 1, in order to perform Single drop/bubble breakage experiments. Two definitions of particle breakage events were studied; initial breakage and cascade breakage.

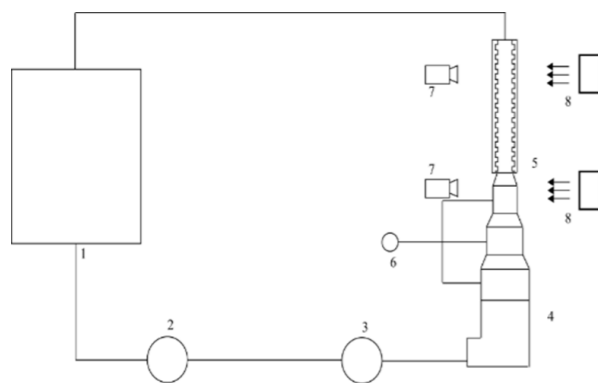

Figure 1. Schematic drawing of the experimental setup. 1. Water tank and phase separator, 2. water pump, 3. flow meter, 4. drop-let generation section, 5. breakage section, 6. oil syringe pump, 7. two cameras, 8. illumination.

In known turbulent flows characterized by LDA measurements (Laser Doppler Anemometry), these studies enable improved accuracy in population balance modeling (PBM) by determining:

- The average number of daughter particles produced
- The breakage time
- The breakage probability
- The breakage frequency
- The daughter size distribution

## MAIN RESULTS

A model energy spectrum was employed in order to develop a model for the structure function for the whole spectrum. The spectrum changes in shape as a function of the Reynolds number. A breakage closure model for the PBM has been developed based on the single bubble data gathered from the rig. By use of the breakage closures determined using the experimental data obtained for single bubble experiments, model validation was performed comparing the model predictions with independent bubble breakage data found in the literature. As shown in Figure 2, the model predictions are in good agreement with the experimental data.

A similar closure model for droplet breakage is under development and is planned to be published in 2024.

## SELECTED PUBLICATIONS

- Herø, E. H., La Forgia, N., Solsvik, J., Jakobsen, H. A. «Single Drop Breakage in Turbulent Flow: Statistical Data Analysis». Chem Eng Sci: X, 8, 100082, 2020. <https://doi.org/10.1016/j.cesx.2020.100082>
- Foroushan, HK and Jakobsen, HA. "Experimental study of single bubble breakage in turbulent flow field: Evaluation of breakage models". Chem Eng Sci 253, 117584. (2022).

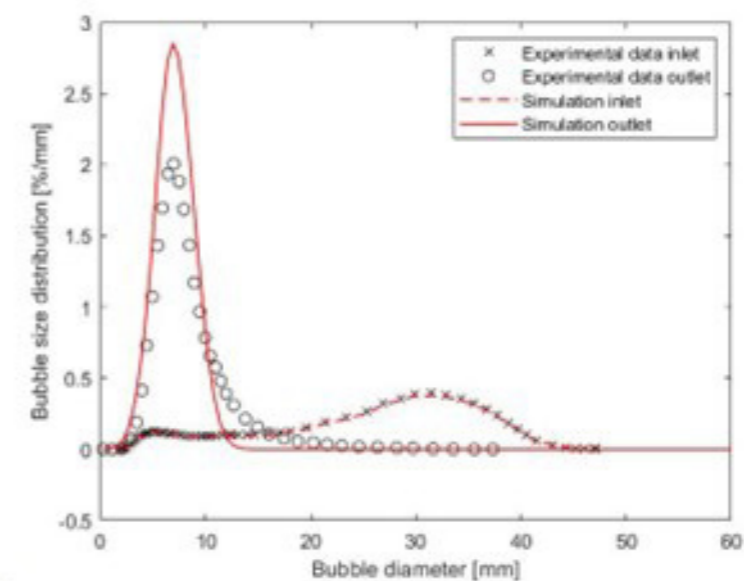

Figure 2. Breakage model validation.



# Membrane process for subsea natural gas dehydration: Modeling and experimental studies



PhD student:  
**Kristin Dalane**



PhD student/Postdoctoral fellow:  
**Mahdi Ahmadi**



Researcher:  
**Niloufar Keshavarz Rezaei**

Natural gas (NG) streams must be dehydrated before transportation, to avoid corrosion and hydrate formation in pipelines. Currently, triethylene glycol (TEG) absorption is employed for NG dehydration, the performance of which, however, is limited by the water/TEG vapor-liquid-equilibrium (VLE). Its complex process also makes it impossible to operate subsea. Membrane separation is advantageous for its modular and compact system and small footprint. Hence, a closed-loop membrane process was proposed to replace TEG absorption. The process includes a membrane contactor for NG dehydration and a thermopervaporation unit for TEG regeneration (Figure 3 (a)). This project aimed to design, optimize, and evaluate the proposed membrane process by modeling and experiments.

## THE MAIN RESULTS

1. Membrane contactors were modeled and validated with experimental results. Composite membranes consisting of thin Teflon AF2400 layers (~2 $\mu$ m) on porous support were developed; low water content in the outlet (dew point of below -20 °C) was achieved. TEG loss of < 0.008 liter/MSm<sup>3</sup> was documented, three orders of magnitude less than the maximum TEG loss allowed by pipeline specifications. The membranes under subsea NG conditions exhibited stable long-term operation during laboratory testing.
2. Thermopervaporation process conditions and membrane design parameters were optimized. The water recovered from the wet TEG has a purity of above 99.98, implying that the removed water may be discharged

directly into the sea. High separation factors were obtained for all feed solutions at the studied operating temperatures, outperforming VLE-based separation (Figure 3 (b)).

3. Process optimization and evaluation of the closed-loop membrane process were carried out by modeling and simulation. A new process design using a gas membrane (dry NG as the sweep gas) to replace thermopervaporation was also evaluated for solvent regeneration.

## SELECTED PUBLICATIONS

- M Ahmadi, A Lindbråthen, M Hillestad, L Deng. "Subsea natural gas dehydration in a membrane contactor with turbulence promoter: An experimental and modeling study". Chemical Engineering Journal 2021, 404, 126535. <https://doi.org/10.1016/j.cej.2020.126535>
- K Dalane, NT Josefsen, L Ansaloni, M Hillestad, L Deng. "Thermopervaporation for regeneration of triethylene glycol (TEG): Experimental and model development". Journal of Membrane Science 2019, 588, 117205. <https://doi.org/10.1016/j.memsci.2019.117205>

## INDUSTRY COLLABORATION

The above research projects have cooperated with Aker Solutions, TotalEnergies and Equinor on design and supervision of the research projects, and on co-authoring of scientific papers.

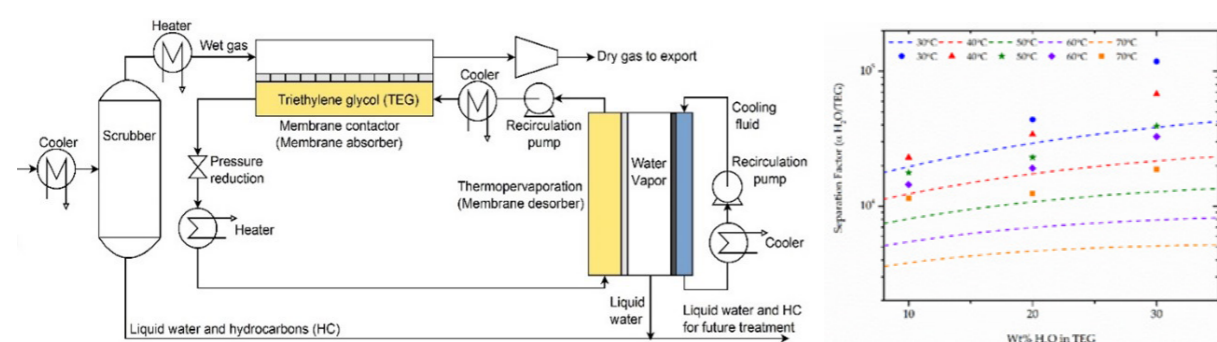

Figure 3: (a) Proposed subsea NG dehydration process diagram and (b) Separation factor in thermopervaporation compared to VLE-based separation. Symbols are for thermopervaporation at varying conditions, and dash lines are VLE-based separation.

# Compact oil-water separation



PhD student:  
**Håvard S. Skjefstad**  
Compact separation concepts



PhD student:  
**Hamidreza Asaadian**  
Subsea bulk oil-water separation

Oil fields usually produce large amounts of water when they mature, which bottlenecks topside facilities, and cause additional energy losses. A technology that can be used to mitigate this issue is compact subsea separation using parallel pipes. This technology aims to remove as much water as possible from the inlet stream while honoring the specified maximum allowed oil-in-water concentration (that depends on the destination of the separated stream). It is a modular and adaptative concept that is especially attractive for deep waters. However, velocities in the separator are usually higher than those in gravity vessels which makes it more sensitive to operational conditions and fluid properties, and consequently makes it difficult to accurately predict separation performance. Expensive big-scale test campaigns are often required to verify their suitability.

These two PhD projects studied experimentally and numerically compact bulk oil-water separation in parallel pipes suitable for subsea deployment with the overall goal of increasing the technology readiness level. The PhD project of Håvard Skjefstad proposed a separator design, built the experimental facilities and a medium-scale prototype, did performance measurements with model oil and model oil with surfactants, optimized the design, and performed numerical simulations using computational fluid dynamics (CFD). The PhD project of Hamidreza Asaadian did performance measurements using model oil spiked with crude and with small amounts of air, measured the separation performance of a tapping point for different operating conditions, and developed and tuned models and methods to perform separator design. Some novel elements are: using crude spiking to mimic separation characteristics of real crude-water mixtures, gathering of experimental data from small scale (droplet distributions) to big scale (separation efficiency), development and verification of the drainage potential curve concept to characterize tapping point separation performance.

The experimental facilities represent an investment of approximately 1.5 MNOK, of which SUBPRO contributed with roughly one half.

The project results provide 1) an "open source" bulk oil-water separator design backed up by 2) open, comprehensive and extensive high quality experimental data sets also suitable for pipe oil-water flow model development and validation and 3) a method using numerical modeling for designing the multi parallel pipe separator. The results can be useful for other bulk oil-water parallel separator designs like the Dual Pipe Separator (DPS) and SpoolSep. For example, the experiments show that parallel pipes can experience flow maldistribution, and solutions are provided to eliminate this phenomenon.



Figure 4a) Photo of the experimental facilities, depicting the separator, control station and flow meters on the top floor and pumps, storage tank on the ground floor.

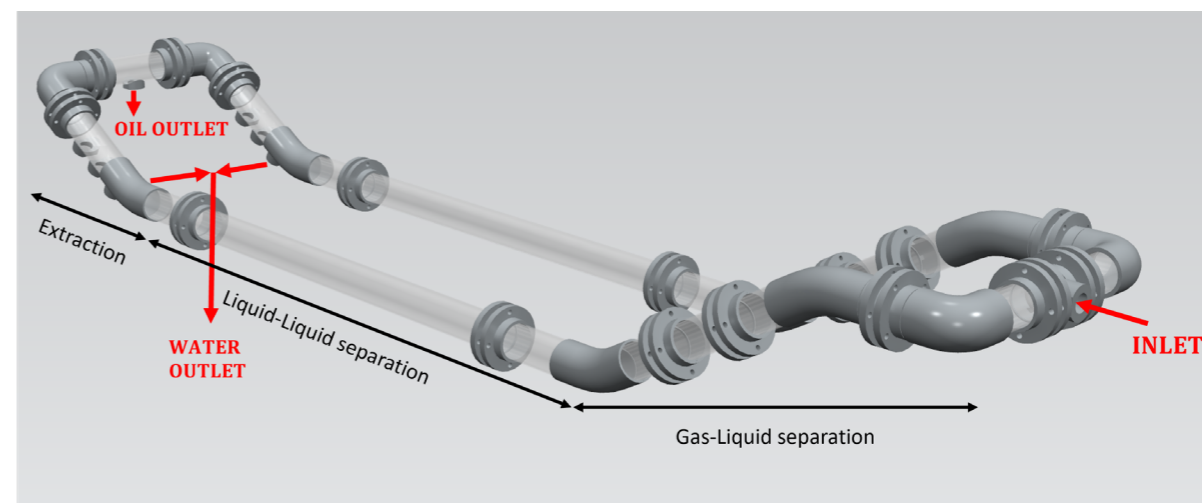

Figure 4b) 3D drawing of the separator prototype studied.

	no crude spiking				185 ppm crude spiking				400 ppm crude spiking				400 ppm crude spiking and air			
total flow rate [L/min]	78,8	79,1	93,2	98,4	44,8	72,1	88,6	99,3	39,8	67,4	84,9	98,3	31,4	63,0	80,8	93,1
500	90,5	98,0	99,0	99,5	65,8	90,4	97,5	99,3	67,7	86,6	95,3	98,1	37,4	66,2	88,3	97,2
300	98,2	99,8	100,0	100,0	95,8	99,9	100,1	100,0	91,8	97,7	98,9	99,4	75,0	77,2	97,2	99,2
	30,0	50,0	70,0	90,0	30,0	50,0	70,0	90,0	30,0	50,0	70,0	90,0	30,0	50,0	70,0	90,0
	Water cut [%]															

Figure 4c) deterioration of separation efficiency values (for several combinations of total flow rates and water cuts) when transitioning from model oil to model oil spiked with crude and adding air.



Left pipe



Right pipe

Fig. 5 A side picture of the separator branches showing maldistribution phenomenon, instead of exhibiting identical flow distribution, the left branch shows stratification while the right branch shows an emulsion layer



## INDUSTRY COLLABORATION

Equinor, TotalEnergies and AkerSolutions provided continuous input to the project during its execution. Subsea 7 had high interest in using the separation concept for the wax cold flow unit that requires upstream water separation.

## SELECTED PUBLICATIONS

- Skjefstad, H.; Stanko, M.  
*“Experimental performance evaluation and design optimization of a horizontal multi-pipe separator for subsea oil-water bulk separation”*.  
Journal of Petroleum Science and Engineering, Volume 176, 2019, Pages 203-219, ISSN 0920-4105.  
<https://doi.org/10.1016/j.petrol.2019.01.027>.
- Asaadian, H., Stanko, M.  
*“Experimental quantification of the performance of a horizontal multi-pipe bulk separator of water and oil with crude spiking”*.  
J Petrol Explor Prod Technol (2023).  
<https://doi.org/10.1007/s13202-023-01672-9>
- Asaadian, H., Stanko, M.  
*“Experimental quantification of the performance of a horizontal multi-pipe bulk separator of water and oil with crude spiking”*.  
J Petrol Explor Prod Technol (2023).  
<https://doi.org/10.1007/s13202-023-01672-9>
- Asaadian, Hamidreza; Harstad, Sigurd; Stanko Wolf, Milan Edvard.  
*“Drainage Potential Curves of Single Tapping Point for Bulk Oil-Water Separation in Pipe”*.  
Energies 2022 ;Volum 15.(19) s.

*From the left: PhD student/Postdoctoral fellow Mahdi Ahmadi and PhD student Eirini Skylogianni working with the membrane thermopervaporation setup for gas dehydration testing.*





RESEARCH AREA

# System Control

The System control research area has focused on methods for systematically designing control systems and digital twins to realize intelligent autonomous production systems that ensure safe and optimal operation of subsea production and processing systems.



**Professor Johannes Jäschke**  
Research Area Manager  
Department of Chemical Engineering, NTNU

## PROJECT MANAGERS AND SUPERVISORS

Professor Johannes Jäschke, Department of Chemical Engineering, NTNU	Professor Sigurd Skogestad, Department of Chemical Engineering, NTNU	Associate prof. Christian Holden, Department of Mechanical and Industrial Engineering, NTNU	Associate Prof. Milan Stanko, Department of Geoscience and Petroleum and Department of Chemical Engineering, NTNU	Associate prof. Idelfonso Nogueira, Department of Chemical Engineering, NTNU	Assistant Prof. Dinesh Krishnamoorthy, Department of chemical Engineering, NTNU	Adjunct Prof. Gunleiv Skofteland, Equinor

### SCOPE OF THE RESEARCH AREA SYSTEM CONTROL

Subsea production and processing systems such as sub-sea separators, boosters and fluid transport systems are difficult to access, and rely on remote operation. As intervention is limited and very costly, it is important to have robust and reliable automatic methods for controlling and optimizing these processes under fluctuating varying and uncertain conditions. Further, it is essential to remotely monitor and predict the condition and performance of the process equipment, to optimize the performance and enable condition-based maintenance. The four focus areas in the research area Systems control aim to address these challenges that come with operating processes subsea:

1. Development of simplified control-oriented models for subsea processes
2. Production optimization
3. Novel control approaches
4. Estimation of unmeasured variables and virtual flow metering

Altogether, 11 PhD students, 2 postdoctoral researchers, and 1 researcher worked in these research areas. Each of the PhD students and postdoctoral researchers were assigned one main focus area but contributed also to other areas.

## Project overview

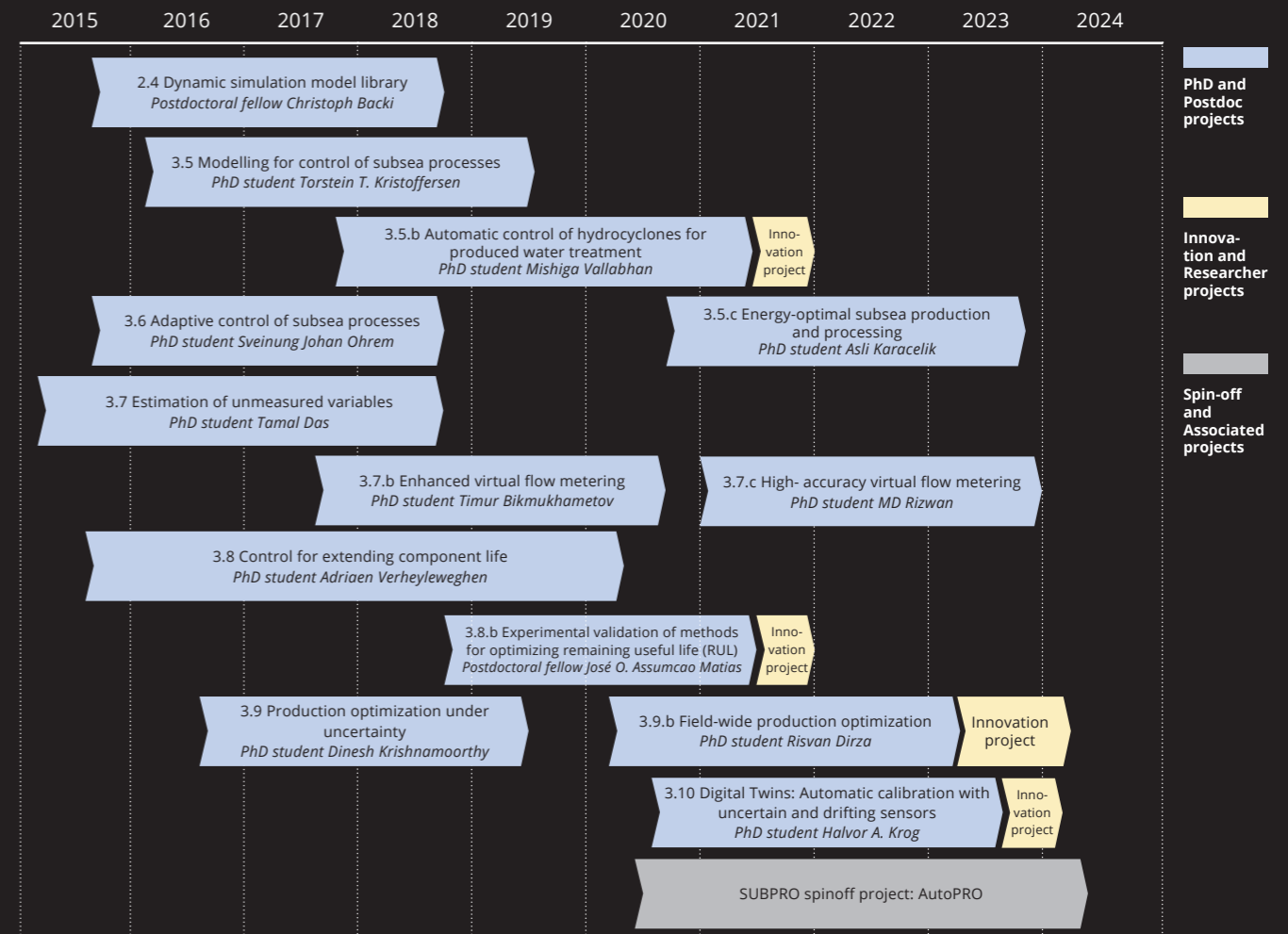

The System Control team at the compact subsea separator test rig.

From the left: Associate Professor Christian Holden, PhD student Md Rizwan, PhD student Halvor Aarnes Krog, Professor Johannes Jäschke, Professor Sigurd Skogestad, PhD student Risvan Dirza, PhD student Asli Karacelik.

Adjunct Professor Gunleiv Skofteland (Equinor), Associate Professor Milan Stanko, Assistant Professor Dinesh Krishnamoorthy and Associate Prof. Idelfonso Nogueira were not present when the picture was taken.



# Development of simplified control-oriented models for subsea processes



Postdoctoral fellow:  
**Christoph Backi**



PhD student:  
**Tamal Das**



PhD student:  
**Mishiga Vallabhan**



PhD student:  
**Sveinung J. Ohrem**

For control and optimization of large-scale process systems, it is not necessary to develop models that capture all phenomena in the process. By developing simple-control oriented models that capture the essential behavior of the process, while omitting unnecessary details, one achieves optimal operation with significantly reduced efforts and costs for developing and maintaining the models.

We have focused on modelling of subsea separators, such as gravity separators, cyclonic separators, and flotation units as well as compressors, and development of simplified models for larger production systems that can be combined and used for overall system optimization.

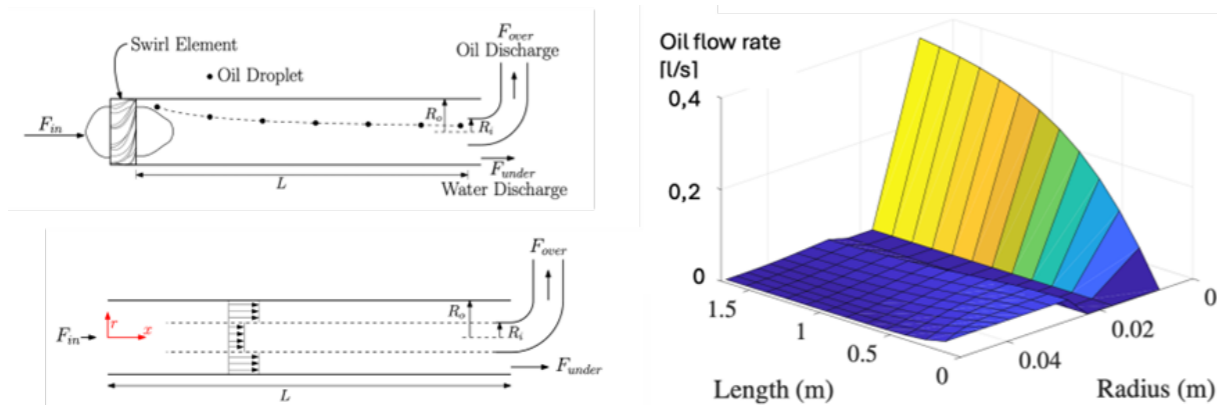

Figure 1: Example of a control-oriented model of an in-line cyclonic separator for purifying water. The general concept is given on the left top, and a very simplified velocity profile is assumed to make the model easy to solve. Right: Oil flow rate along the length and the cross-section of the separator.

# Production optimization



PhD student:  
**Adriaen Verheyleweghen**



PhD student:  
**Dinesh Krishnamoorthy**



PhD student:  
**José Otavio Assumpcao Matias**



PhD student:  
**Asli Karacelik**



PhD student:  
**Risvan Dirza**

Optimizing operation conditions to increase production has very large economic benefits. We have considered model-based and model free approaches for developing methods for production optimization. Important challenges such as handling uncertainty, degrading equipment and computational complexity were addressed. Examples include decentralized approaches for produced water purification (Das et al, 2019), and implementation of distributed feed-back based Real-time optimization methods (Dirza et al, 2022).

A variety of production optimization methods has been developed and taken closer to industrial application by testing them on an experimental rig that emulates gas-lift optimization, and that also allows for testing algorithms that account for equipment degradation (Matias et al., 2022, Verheyleweghen & Jäschke 2017).

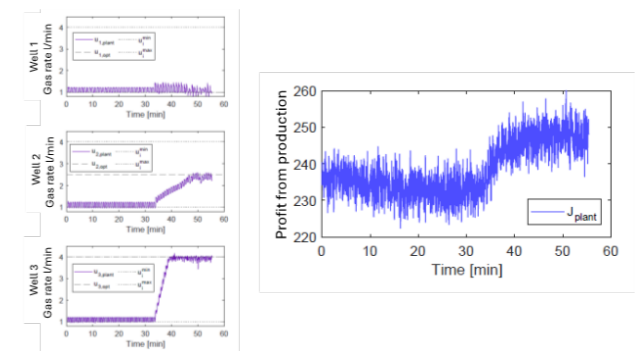

Figure 3: Example of a model-free production optimization algorithm tested in the experimental production optimization rig. The algorithm is switched on after ca 35 minutes of the test run and adjusts the three gas injection rates (left) optimally to maximize the profit and reach the maximum production rate.

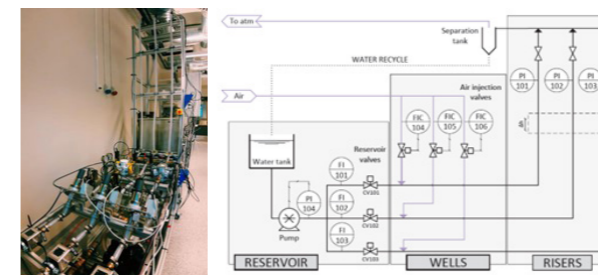

Figure 2: The experimental rig for testing optimization of gas-lift, including monitoring of equipment degradation

# Control approaches



PhD student:  
**Torstein Kristoffersen**



PhD student:  
**Sveinung J. Ohrem**



PhD student:  
**Mishiga Vallabhan**

In this focus area, we studied general methods for controlling subsea processes, such as compact separation, compression and pumping. Selected control algorithms were validated in a subsea separation lab which was designed and constructed as part of this project.

Adaptive control approaches and simplified uncertainty-aware robust model predictive control methods were developed and tested by simulation compared to lab experiments.

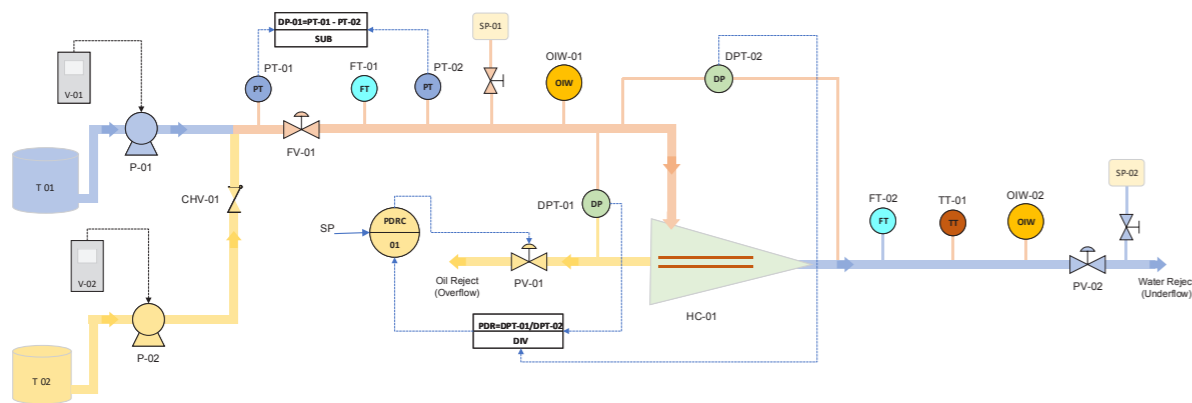

Figure 4: Simplified flow sheet of the compact separation lab



Figure 5: SUBPRO Compact separation lab for testing control algorithms

# Estimation of unmeasured variables and virtual flow metering



PhD student:  
**Tamal Das**



PhD student:  
**Timur Bismukhametov**



Postdoctoral fellow:  
**Christoph Backi**



PhD student:  
**Halvor A. Krog**



Researcher:  
**Carine de Menez Rebello**

A common challenge in industrial subsea production and processing systems is that some important variables cannot be measured directly and must be estimated indirectly using alternative available measurements combined with calculation and modelling. For example, it is important to know the flow rates of the produced oil, gas and water phases in order to allocate production for optimal reservoir depletion. Estimates of other unmeasured variables, such as fluid densities, or pump efficiencies are also important to ensure that digital twins match the real production system.

The research projects have developed hybrid methods that combine novel algorithms for estimation and machine learning with simple first-principles (physical) models, and development of advanced dynamic state estimation methods.

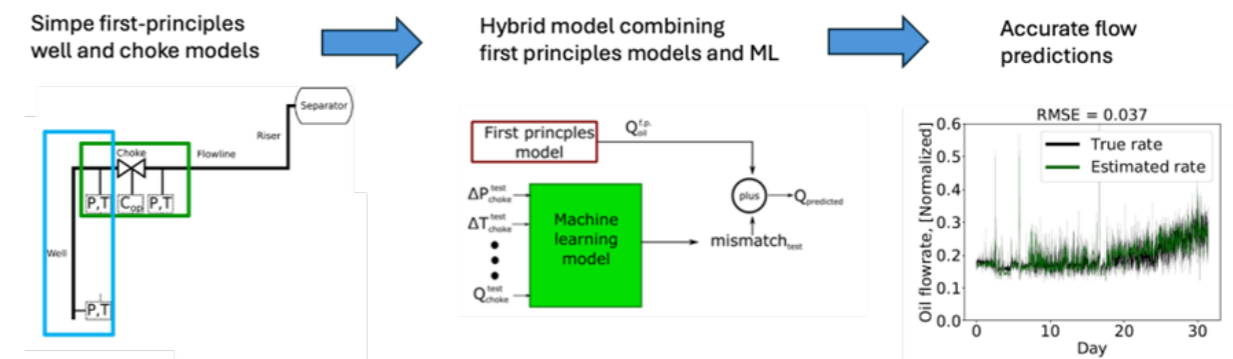

Figure 6: Estimation example: Simplified knowledge-based models for a well and a choke were combined with machine learning (ML) approaches to accurately estimate the hydrocarbon flow rates. The method was tested on field data provided by Equinor



# Industrial collaboration and innovation projects

All projects were set up and conducted in close collaboration with industrial partners. Phd students and postdocs presented their work to the industry partners twice a year in common meetings, often more frequently, and received feedback to ongoing research.

In discussion with the industry partners, promising research results were selected for further development in innovation projects, where the results were further developed in close collaboration with industry for a provided case study.

The research area has collaborated closely with Kongsberg Digital, and used their process simulators K-Spice and Ledaflo as a basis for further developments.

The following innovation projects were selected to further mature the research results:

- *Estimation of liquid flowrate and sensor drift on subsea booster pump.*  
In this project we applied the methods for calibration of digital twin process models developed by PhD candidate Halvor A. Krog to the Åsgard subsea processing system, based on models and data provided by Equinor, Aker Solutions and Kongsberg Digital. Results on accurate estimation of a pump curve were obtained in close collaboration with industry partners.
- *Production optimization with data from Aker BP.*  
(PhD candidate Risvan Dirza).
- *Experimental Studies in Gas-lift optimization.*  
The rig for studying production optimization with eroding elements was modified by postdoc Jose Matias to study gas-lift optimization algorithms.
- *Control for extending remaining component life.*  
Preparing for experimental verification of algorithms to predict and optimize component life. (PhD candidate Adriaen Verheyleweghen).
- *Production optimization under uncertainty.*  
Connecting SUBPRO projects to ongoing technology development in Equinor and establishing/providing collaboration between SUBPRO projects and Equinor (PhD candidate D. Krishnamoorthy).
- *Automatic control of subsea separation*  
(PhD candidate M. Vallabhan, J.), Experimental testing of new control schemes for hydrocyclones.

*The spin-off AUTOPRO (see below) was initiated by SUBPRO in collaboration with AKER BP.*

## 1. RESEARCH EXCELLENCE

Researchers from the Systems and control group received recognition internationally for their work:

For his excellent PhD work, **PhD student Dinesh Krishnamoorthy** received Dimitri. N. Chorafas Foundation Award, the Excellence in Computer-Aided Process Engineering (CAPE) PhD Award by the European Federation of Chemical Engineers (EFCE), and the NTNU Faculty of Natural Sciences Best PhD Thesis Award, and he was invited to give a keynote presentation at the IFAC Adchem.

- **PhD student Adriaen Verheyleweghen** received the Young Author award finalist.
- **Spin-off project AutoPRO:** Keynote lecture at Adchem.

## SELECTED PUBLICATIONS

- C.J. Backi, B.A. Grimes, S. Skogestad.  
*"A control-and estimation-oriented gravity separator model for oil and gas applications based upon first-principles"*. Industrial & Engineering Chemistry Research, 2018, DOI: 10.1021/acs.iecr.7b04297.
- T. Das, S.J. Heggheim, M. Dudek, A. Verheyleweghen, and J. Jäschke.  
*"Optimal Operation of a Subsea Separation System Including a Coalescence Based Gravity Separator Model and a Produced Water Treatment Section"*. Industrial & Engineering Chemistry Research 2019 58 (10), 4168-4185, DOI: 10.1021/acs.iecr.8b04923.
- D. Krishnamoorthy, B. Foss, S. Skogestad.  
*"Steady-state real-time optimization using transient measurements"*. Computers & Chemical Engineering, Volume 115, 2018, Pages 34-45, ISSN 0098-1354, DOI: 10.1016/j.compchemeng.2018.03.02.
- Verheyleweghen, J. Jäschke.  
*"Framework for Combined Diagnostics, Prognostics and Optimal Operation of a Subsea Gas Compression System"*. IFAC-PapersOnLine, Volume 50, Issue 1, 2017, Pages 15916-15921, ISSN 2405-8963, DOI:10.1016/j.ifacol.2017.08.2365.
- T. Bikmukhametov, J. Jäschke.  
*"Combining machine learning and process engineering*

*physics towards enhanced accuracy and explainability of data-driven models"*. Computers & Chemical Engineering, Volume 138, 2020, 106834, ISSN 0098-1354, DOI:10.1016/j.compchemeng.2020.106834.

- Mishiga Vallabhan K G, Christian Holden, and Sigurd Skogestad.  
*"A First-Principles Approach for Control-Oriented Modeling of De-oiling Hydrocyclones"*. Industrial & Engineering Chemistry Research 2020 59 (42), 18937-18950 DOI:10.1021/acs.iecr.0c02859.
- S.J. Ohrem, H.S Skjefstad, M. Stanko, and C. Holden.  
*"Controller Design and Control Structure Analysis for a Novel Oil-Water Multi-Pipe Separator"*. Processes 7, no. 4: 190. DOI: 10.3390/pr7040190-(2019).
- T.T. Kristoffersen, C. Holden.  
*"Modelling and control of a wet-gas centrifugal compressor"*. IEEE Transactions on Control Systems Technology 29 (3), pp1175-1190, DOI:10.1109/TCST.2020.2993224
- R. Dirza, J. Matias, S. Skogestad, D. Krishnamoorthy.  
*"Experimental validation of distributed feedback-based real-time optimization in a gas-lifted oil well rig"*. Control Engineering Practice, Volume 126, 2022, 105253, ISSN 0967-0661, https://doi.org/10.1016/j.conengprac.2022.105253
- J. Matias, J.P.C. Oliveira, G.A.C. Le Roux, J. Jäschke.  
*"Steady-state real-time optimization using transient meas-*

*urements on an experimental rig"*. Journal of Process Control, Volume 115, 2022, Pages 181-196, ISSN 0959-1524, https://doi.org/10.1016/j.jprocont.2022.04.015

- H. A. Krog, J. Jäschke.  
*"The Simple Solution for Nonlinear State Estimation of Ill-Conditioned Systems: The Normalized Unscented Kalman Filter"*. IFAC-PapersOnLine, Volume 56, Issue 2, 2023, Pages 5951-5956, ISSN 2405-8963, https://doi.org/10.1016/j.ifacol.2023.10.626

# AutoPRO: Digitalization for autonomous prognosis and production optimization in offshore production systems

A SUBPRO SFI spin-off project 2020-2024



**Professor Johannes Jäschke,**  
NTNU Systems Control,  
Project leader and PhD supervisor

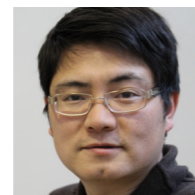

**Professor Yiliu Liu,**  
RAMS Systems Control  
NTNU, PhD supervisor



**Edmary Altamiranda,**  
Aker BP, Industrial PhD supervisor

The collaboration between SUBPRO and the industry partners resulted in the spin-off project AutoPRO, funded by the Norwegian Research Council and Aker BP. The project involves the Department of Chemical Engineering and the RAMS group from Department of Mechanical and Industrial Engineering at NTNU, and is a collaboration project between NTNU, Aker BP and 3 Chinese Universities: China Univ. of Petroleum (East China), Ocean University of China, and Beihang University. On the Chinese side, the industrial partners are Yantai Jereh and the Chinese National Offshore Oil Cooperation (CNOOC).

The primary research question addressed in AutoPRO is:

*How can digitalization help to synchronize and provide optimal production and maintenance decisions in subsea oil and gas production systems?*

The AutoPRO project develops new technologies to facilitate the digital transformation in the oil and gas industry. More specifically, we use methods from big data, artificial intelligence and machine learning, combined with in-depth domain knowledge, to develop new approaches for optimal decision-making in operations, control and maintenance.

In AutoPRO, there are two ongoing PhD projects and one postdoc project at NTNU. The projects are associated to the Systems Control Group and the RAMS group in SUBPRO:

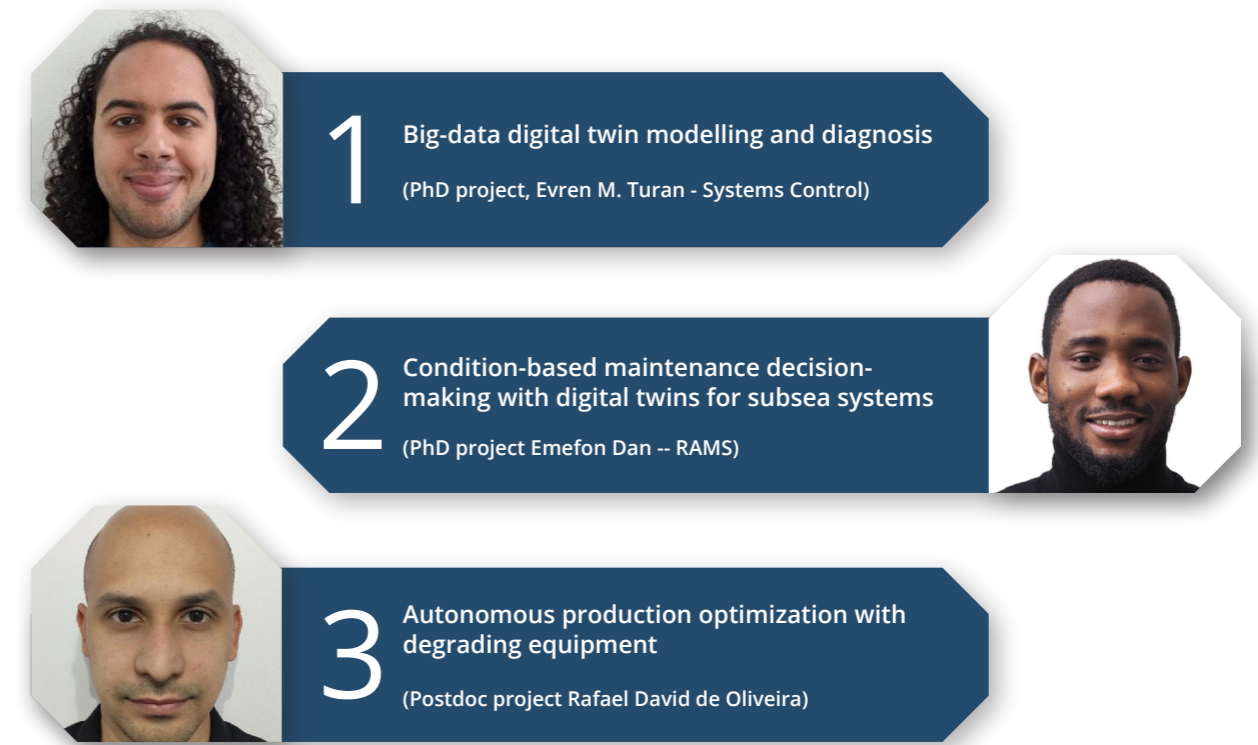

## AutoPRO overview

IKTPLUS Forskningsrådet

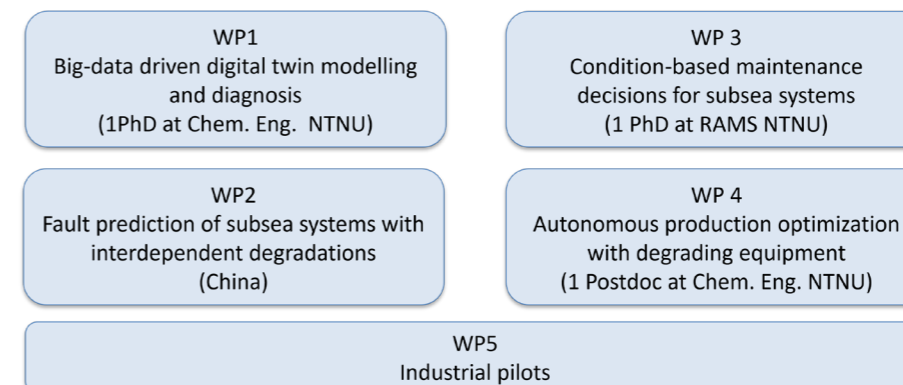

Figure 1 AutoPRO Project organization.

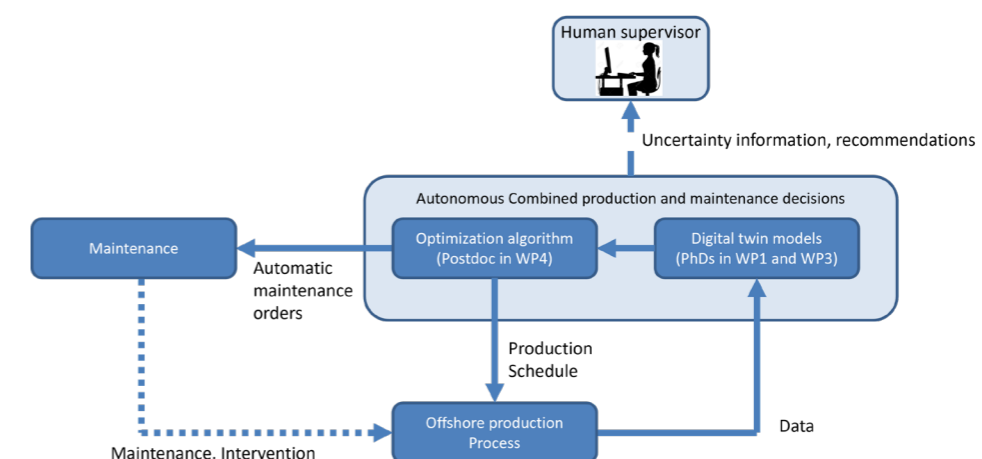

Figure 2 AutoPRO concept for realizing autonomous production, including automatic maintenance planning. Only high-level information is passed to the human supervisor



# PhD education

**Being a PhD student in SUBPRO has given a broad experience with industry oriented and cross discipline research in an international environment.**

In SUBPRO it has been a goal that the students shall not only become specialists in their own field, but also learn about implementation of their project results in the industry, working in teams, sharing of knowledge across disciplines and participation in international networks. This has prepared the students for jobs both in the industry and academia.

## INDUSTRIAL EXPOSURE

The SUBPRO PhD students were exposed to an industrial context from day one.

They have followed an introductory course in subsea production and processing, to get an overview of the field. In the later years, this course was conducted by Equinor.

Many of the research projects had close cooperation with the industry partners through case studies, discussion about research design, application of results etc.

The students presented their work and results for the industry partners in reference groups twice a year, where they participated in discussions about industrial relevance and possible applications of their scientific achievements.

The PhD students also presented their work at national and international industrial conferences like ESREL, Subsea Valley and Underwater Technology Conference (UTC).

Once a year the researchers in SUBPRO, including the PhD students usually went for an excursion to one of the industry partner's industrial sites.



**Kimberly Mayes**

**Senior advisor, The Research Council of Norway**

*«SUBPRO has educated a significant number of PhD students and post-docs who understand the needs of the Norwegian industry.*

*The students are well connected to the industrial partners. In connection with the Midway evaluation of SUBPRO in 2019, several of the PhD students and postdocs met with the evaluation team. The PhD students and postdocs, were impressive, both individually and as a group. They articulated very clearly the many benefits of being in the Centre, including opportunities for industry collaboration, group site visits, international exchanges and social activities.»*

## CROSS DISCIPLINE WORK

SUBPRO has been a cross disciplinary project, involving four departments and three faculties at NTNU, and a broad range of industrial challenges across technical disciplines. The industry urged the researchers to put their heads together and create synergies between the projects. This became the working culture of SUBPRO. Several projects cooperated on laboratory experiments, modelling and writing of common papers. Also, senior staff at NTNU increasingly collaborated across departments to initiate new cross discipline projects.

The PhD students arranged internal technical seminars (PhD forums) at regular intervals, getting to know other fields of research and relating to other projects

## INTERNATIONAL COLLABORATION

The PhD students had the opportunity to go on work visits and exchange periods at other universities and research institutions around the world.

## SOCIAL EXPERIENCE

SUBPRO arranged social excursions annually (except during the Corona epidemic), where the whole project team went to recreational sites to do outdoor sports activities and socialize. This was combined with technical sessions. From 2019, the social events were arranged jointly for SUBPRO and BRU 21, a sister project on subsea technology at NTNU.

Also the fact that the researchers in SUBPRO came from all corners of the world (representing about 15 different nationalities) made it a good arena for learning about other cultures.



PhD student Leonardo Sales presenting his project for the industry partners in a Reference group Teams meeting February 2022.



SUBPRO researchers attending the BN Subsea Operations 3rd workshop in Brazil - November 2022.



# Industry collaboration and innovation

## ACTIVE INDUSTRY INVOLVEMENT IN RESEARCH PROJECTS

SUBPRO has been an important arena for collaboration between the industry and NTNU.

The industry partners have been actively involved in the research activities, through:

- Guiding the direction of the research projects
- Sharing knowledge, industrial experience and operational challenges with the research projects
- Offering case projects, development tools and materials for laboratory experiments
- Supervision and training of PhD students and Master students
- Co-authoring of scientific papers

## INNOVATION

Leveraging the academic research results to industrial innovation is at the core of SUBPRO, being a center for research based innovation.

The innovation processes in SUBPRO have been conducted in several ways:

- **Innovation projects**, where PhD students have received extra grants for extending their research into industrial applications, in close collaboration with industry partners
- **Commercial and in-house innovation initiatives** from the industry partners side, where project results have been implemented in commercial systems and in in-house technology
- **Spin-off projects** with active participation of the industry
- **Recruitment of PhD candidates and Master candidates** to the industry partners and to the energy sector as a whole

The Reference group for System control, with industry partner representatives and NTNU researchers, visiting the compact separation lab at Department of Geoscience and Petroleum during a biannual meeting in Trondheim

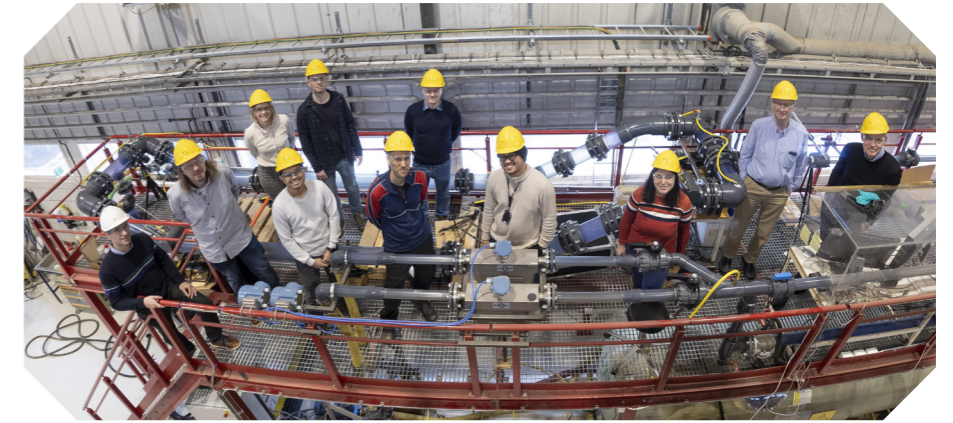

**Adrien Godard**  
Subsea all electrical & process tech leader  
TotalEnergies

«The presence of young students with new eyes and new ideas is also needed for our industry to move ahead.»

«We have two examples of innovation in TotalEnergies, based on SUBPRO results:

- **Virtual flow metering.** The filtering development from SUBPRO has been integrated into TotalEnergies, in all our fields for monitoring of flow.
- **Field Architecture – automated subsea field layout.** In 2023, we integrated in our inhouse tool, the code developed by SUBPRO for automated subsea field layout. So far, the results look good, and the users are happy with it.»



**Edmary Altamiranda**  
Control Systems Lead Technology  
Aker BP

“For Aker BP, SUBPRO has been a valuable arena to explore and progress novel solutions, foster cross industry-academia collaboration and push boundaries on the state of the art in the different research areas to address industry needs with very good results.”

“An example of innovation is a Postdoctoral Research Co-Supervision initiative with Aker BP resulting in OFFA “Optimal and Flexible Field Architectures”, a solution that uses evolutionary algorithms to generate, screen and optimize concept scenarios, using decentralized subsea processing, considering production potential and development cost. This has continued the development internally and it is being implemented and qualified as a commercial software solution.”



**Odd Ivar Haugen**  
Principal Researcher  
DNV

“For DNV the most valuable outcome from SUBPRO, has been the Safety 4.0 IPN spin-off project which we initiated together with Professor May Ann Lundteigen, NTNU. The PhD student, Nanda Zikrullah, is now working for DNV. Our CEO turned to us and the Safety 4.0 project, to initiate DNV’s recommended practice for AI which was published in November 2023.»



**Gunleiv Skofteland**  
Chief Researcher Facilities  
Equinor

“SUBPRO has been a fantastic arena for us to engage with the university, the students and the professors. We have been able to present our challenges and topics, to help forming the research projects».



**Olav Dolonen**  
Lead Field Development Engineer  
Neptune Energy Norge AS

“For Neptune, the research results in SUBPRO have improved our overall understanding of issues regarding subsea processing and hydrocarbon flowline transport. We have utilized some of the findings in our field development work.”



# International collaboration

## 1. SUMMARY

International collaboration has been a major part of SUBPRO research working culture. SUBPRO has organized collaborative research activities in different forms, i.e. SUBPRO/NTNU has been collaborating with Brazilian universities through the INTPART project Brazilian-Norwegian Subsea Operations Consortium SUBPRO. In addition, the PhD students have the opportunity to visit or work for periods at other universities and research institutions around the world. Likewise, visits of international researchers and exchange of academic personal from several renowned international universities was taking place.

In total, through the eight years life span of SUBPRO, there has been active cooperation with at least 18 reputable universities and research institutions across the globe:

**Brazil:**  
 Federal university of Rio de Janeiro /COPPE  
 Federal University of Rio Grande do Sul and Petrobras/ CENPES Research Centre  
 University of Sao Paulo  
 Federal university of Sanat Catarina  
 University of Campinas

**USA:**  
 MIT Boston  
 Carnegie Mellon university

**France:**  
 Mines ParisTech  
 University of Troyes

**The UK:**  
 Imperial College London

**Germany:**  
 University of Aalen

**The Netherlands:**  
 University of Wageningen  
 Eindhoven University of Technology (TU Eindhoven)

**Switzerland:**  
 ETH Zürich

**Denmark:**  
 Aalborg University

**China:**  
 China University of Petroleum  
 Ocean University of China  
 Beihang University

**In addition to:**  
 Some exchange through IAESTE from Czech Republic, Greece and several conferences worldwide such as in Colombia, Dublin, The UAE and Indonesia.

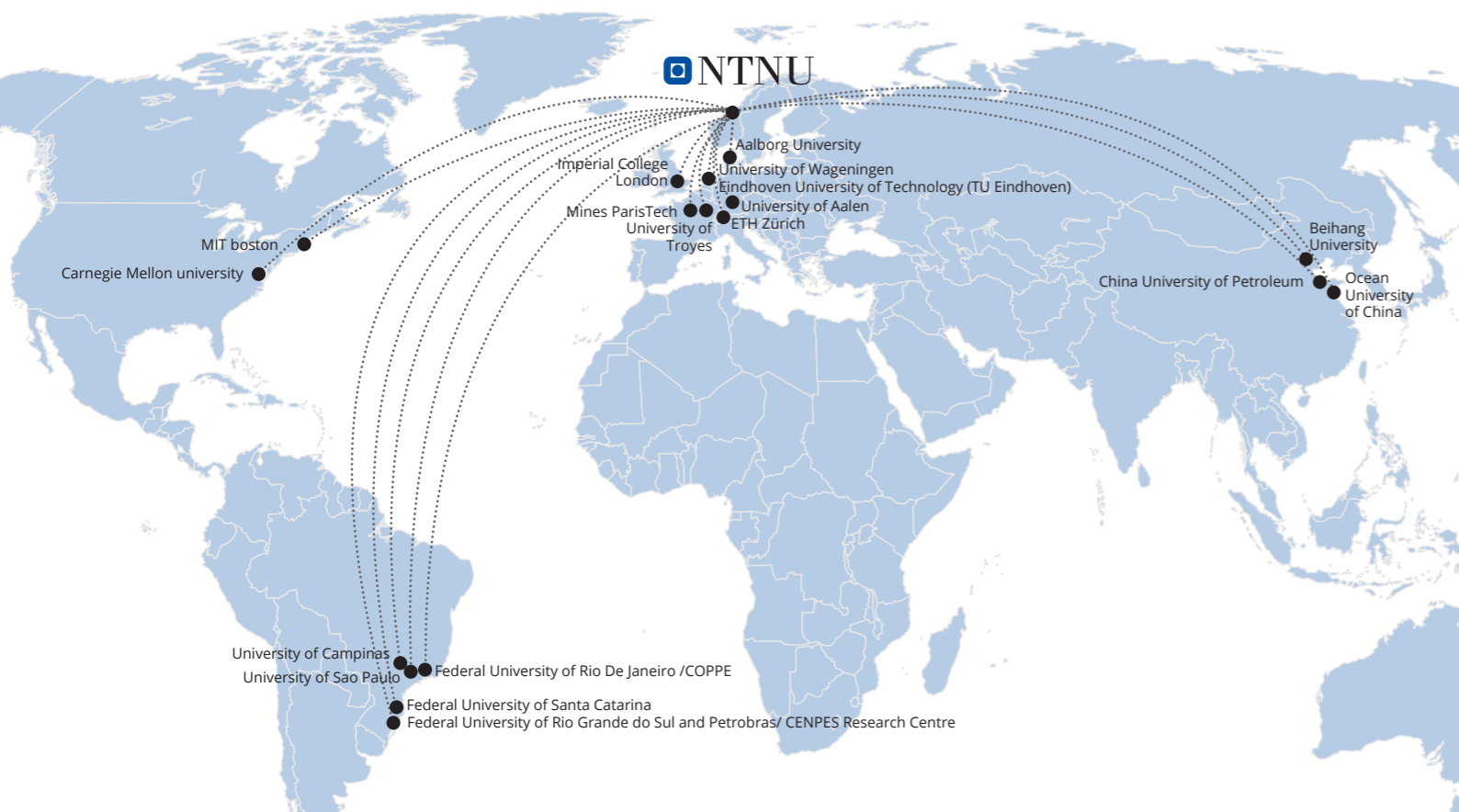

## 2. BRAZILIAN-NORWEGIAN SUBSEA OPERATIONS CONSORTIUM

(BN-SOC) Intpart1, 2017- 2020, and Intpart2, 2022- 2024 RCN, Intpart2 project number. 309880

### Background

Subsea operations have been important for decades, and both countries are at the forefront of this field. The objective of this consortium has been to enable the development of a sustainable and broad collaboration within subsea operations education, research and development, between leading academic and industrial actors in Brazil and Norway.

Through the current consortium, we have assembled a group of leading subsea actors from both academia and industry. Our Brazilian university partners include the top universities in the country: The University of São Paulo (USP), the Federal University of Rio de Janeiro (UFRJ), and the University of Campinas (Unicamp). In addition, Petrobras (Brazil) and Equinor (Norway) have been active members from the industry in the consortium, as well as the engineering company, GCE Ocean Technology (Norway). At NTNU, BN-SOC is coordinated by the Department of Geoscience and Petroleum (IGP) and attached with two Centers for Research-based Innovation – SFI SUBPRO (primary affiliation) and SFI MOVE (sub-project with NTNU in Ålesund and USP).

SFI SUBPRO <https://www.ntnu.edu/subpro/>  
 SFI Move <https://www.ntnu.edu/move>

BN-SOC2 is also attached to the recently formed SUBPRO-Zero initiative, a new center based on SUBPRO that will contribute to net-zero emissions for the offshore industry.  
 SUBPRO- Zero <https://www.ntnu.edu/subpro-zero>

Activities in BN-SOC Intpart programs have been centered around the mobility as a major activity, to facilitate multi-disciplinary collaboration.

During the project period, the consortium has a plan for approximately 20 reciprocal visits and 3 short-term stays per year, from Norway to Brazil and vice versa.

During the project period, the consortium has facilitated approximately 125 reciprocal visits and approx. 33 short-term stays to date, from Norway to Brazil and vice versa. The short-term stays have been instrumental in achieving

joint supervision of Master students, in ensuring valuable research exchange for PhD- and Postdoc.-candidates and joint publications of scientific articles and technical reports. BN-SOC has brought many excellent students from Brazil to Norway, many of whom we still cooperate with independently of the INTPART program. Several MSc. students that have been on exchange from Brazil have later been hired in PhD positions at NTNU, and one PhD candidate from NTNU has been hired in a Postdoc.-position at Unicamp. In addition, these stays have facilitated short courses held at USP, UFRJ and Unicamp through visiting faculty.

To date, 8 journal articles have been published as a result of BN-SOC activity, with additional articles currently under production and / or review, as well as approximately 125 additional conference papers and presentations produced. The BN-SOC programs has hosted 6 workshops in Trondheim (Norway) and 2 in Rio de Janeiro (Brazil). The consortium has been an active participant group in the "November Conference on Brazilian-Norwegian Energy Research" for several years running, including being responsible for hosting sessions, contributing with presentations, and through NTNU, in the planning of the conference.

Through reciprocal visits and regular workshops, BN-SOC's partners have developed and submitted new joint project proposals as a direct result of the project.

Our cooperation through BN-SOC has led to Brazilian partner involvement the newly submitted FME application which is an extension of the SFI project SUBPRO

Our overall conclusion is that the BN-SOC has been a very successful program, which has led to a close cooperation with our Brazilian partners within this field, as well as having been of great value to SFI SUBRO and SFI MOVE.

Trondheim March 6, 2024

Sigbjørn Sangesland

Professor, NTNU



# Governance and Organization

## PROJECT MANAGEMENT STRUCTURE - 2023

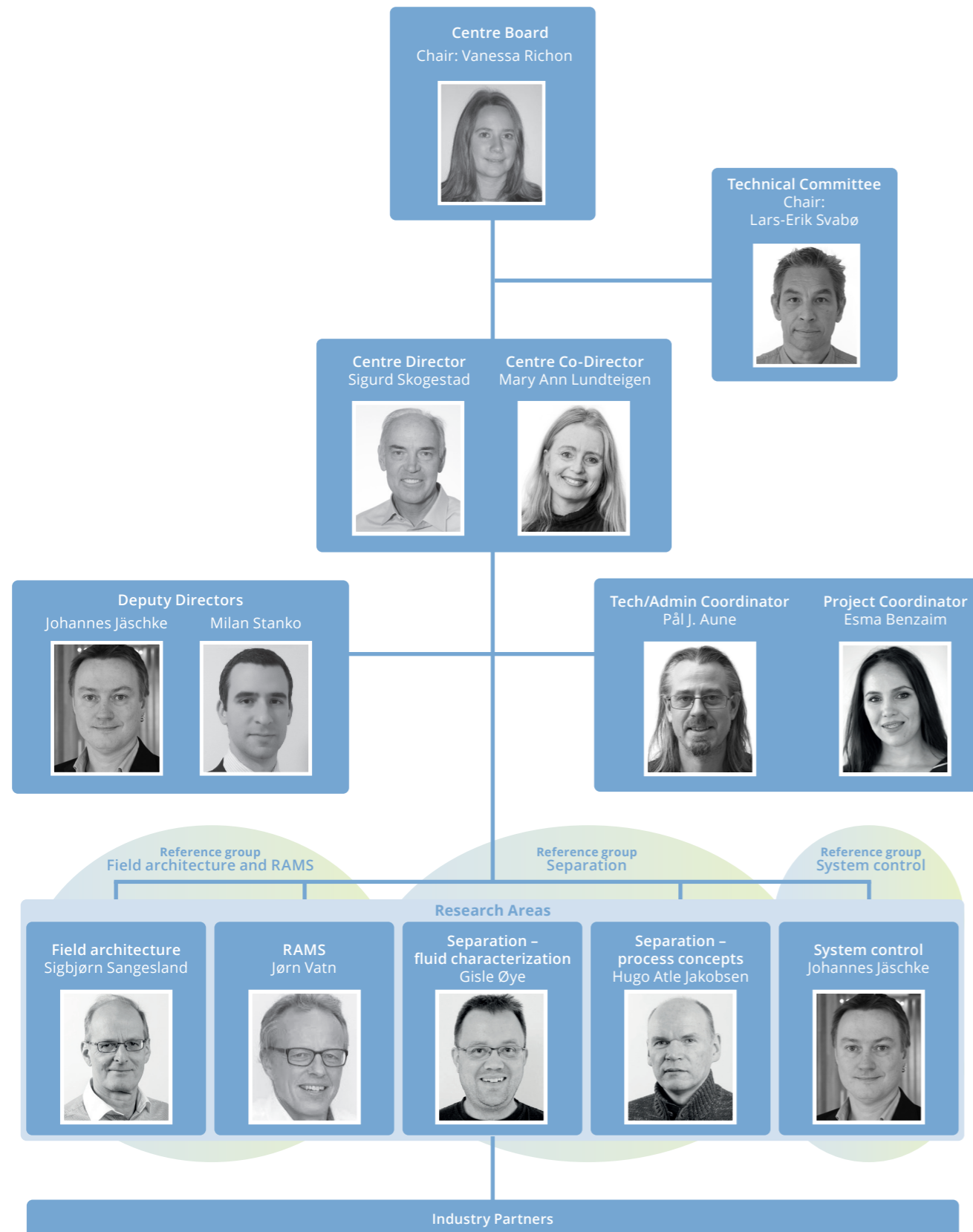

### CENTRE BOARD

The Centre board has one representative from each partner. The board adopts goals and strategies for the Centre and makes decisions about the project portfolio and annual budgets.

### TECHNICAL COMMITTEE

The Technical Committee has typically 1–2 members from each partner. It monitors the technical quality and industrial relevance of the Centre activities and gives technical advice to the Centre board.

### SCIENTIFIC ADVISORY COMMITTEE

The Scientific Advisory Committee was actively involved from 2018 until 2022. It consisted of 1 expert on each of the research areas. The committee assessed the quality of the ongoing research activities and gave advice for further planning of research projects.

### Other collaborative events organized between SUBPRO and the industry partners:

### REFERENCE GROUPS MEETINGS

Three different project reference groups, one for each of the major research areas of SUBPRO, meet the researchers twice a year, for presentation of projects results and giving feedback to continued activities, with special emphasis on innovation.

### THE SUBPRO DAY: TECHNICAL CONTRIBUTIONS TO THE RESEARCH ACTIVITIES

The SUBPRO day is a yearly meeting held in the month of October, where SUBPRO staff, industry partners and other interested parties get an overview of ongoing and new projects and give their input and comments.

### INDUSTRY PARTNER INVOLVEMENT IN RESEARCH PROJECTS

The industry partners are actively involved in the research projects through technical discussions and technical transfer of knowledge, providing advice, co-supervision of PhD students, co-authoring of scientific papers and industrial cases using field data for testing models and software.

### INNOVATION PROJECTS: RESEARCHERS FROM SUBPRO WORKING WITH THE INDUSTRY PARTNERS ORGANIZATIONS

An Innovation project is an extension of a PhD project, funded by SUBPRO, to enable implementation of project results in the industry.

More than 10 innovation projects have been taking place since the start of SUBPRO.

## CHAIRMEN OF THE CENTRE BOARD



Audun Faanes,  
Leading Engineer  
Subsea Technology,  
Equinor  
2015-2017



Stig Lyder Støme  
Chief Subsea  
Engineer  
Lundin Norway  
2017-2019



Frank Børre  
Pedersen  
Vice President and  
Programme Director  
DNV  
2019-2021



Trine Boyer  
Engineer Research  
and Development  
Stavanger Research  
Centre,  
TotalEnergies E&P  
Norge  
2021-2022



Vanessa Richon  
R&D Asset Decarbon-  
ization Manager,  
Stavanger Research  
Centre,  
TotalEnergies EP  
Norge AS  
2022-2023



# Key figures 2015 - 2023

PUBLICATIONS 2015 - 2023	
Journal and conference papers	189

PROJECT DURATION AUGUST 2015 - AUGUST 2023			
Total annual budget (Annual average, 2015-2023)	32 mill. NOK		
Personnel	Expected 2015-2023	Engaged 2015-2023	Female percentage
PhD students	34 <sup>1</sup>	35 <sup>1</sup>	23 %
Postdoctoral scholars	9 <sup>1</sup>	11 <sup>1</sup>	27 %
Researchers (full or part time)	7 <sup>1</sup>	11 <sup>1</sup>	45 %
Professors	22 <sup>1</sup>	22 <sup>1</sup>	27 %
Master students educated (per year)	25	15	30 %

<sup>1</sup> Accumulated over 8 years

## Employment of PhD graduates of SUBPRO

BY SUBPRO PARTNERS	BY OTHER COMPANIES	BY PUBLIC ORGANIZATION	BY UNIVERSITY	BY RESEARCH INSTITUTE	OUTSIDE NORWAY	OTHER	TOTAL
5	15	0	1	3	5	6	35

# Cost Distribution and Funding 2015 - 2023

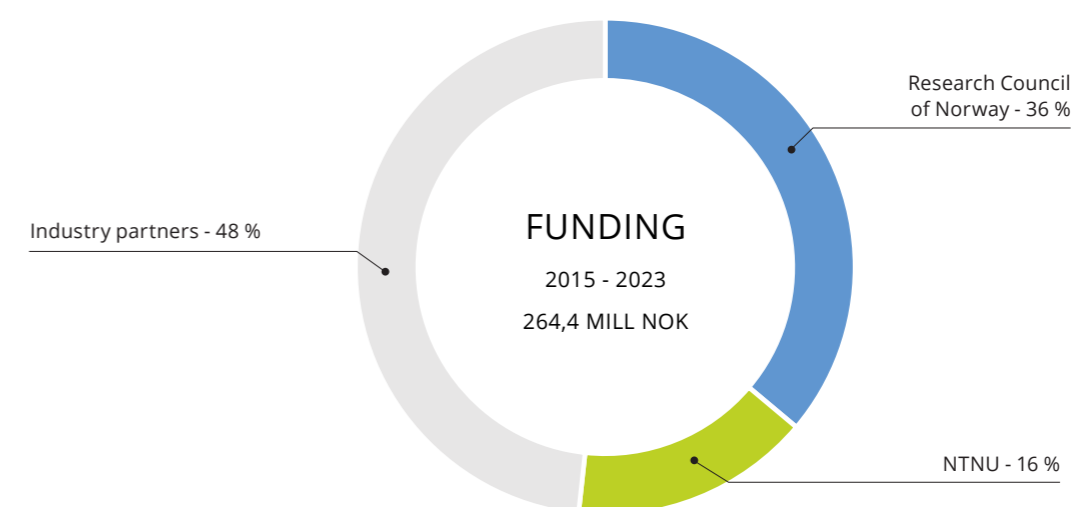
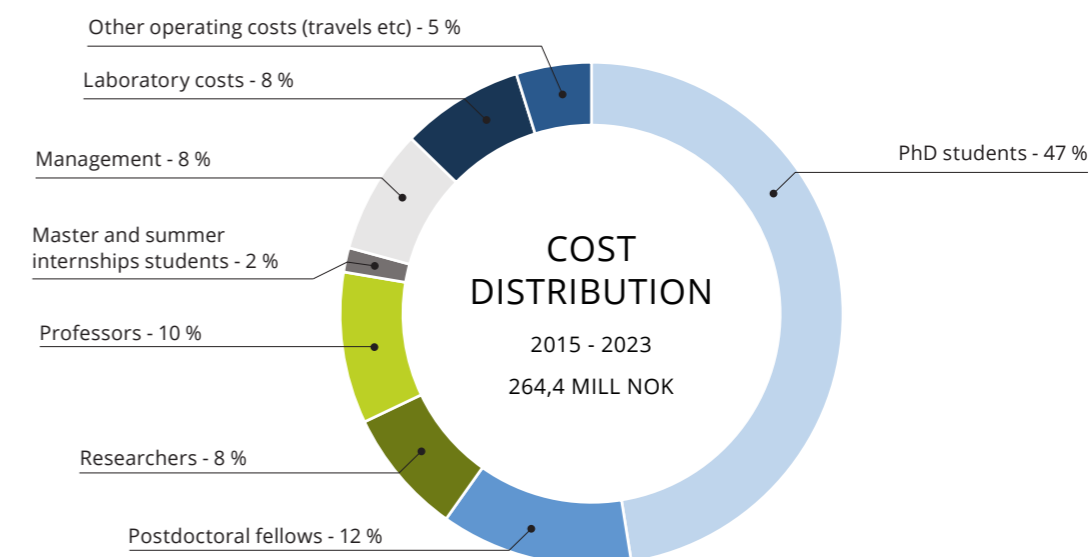

CONTRIBUTOR	CASH	IN-KIND	TOTAL
Host		41 211	41 211
Research partners			
Companies	122 600	5081	127 681
Public partners			
RCN	95 531		95 531
Sum	218 131	46 292	264 423

Numbers in 1000



# Health Security and Environment

## Reported events during 2015 - 2023

There has been no reported HSE accidents connected to SUBPRO staff and laboratories during the lifespan of the project, except few minor incidents which were immi- nently followed-up by the HSE engineer and the Campus service office.

All SUBPRO personnel is required to report HSE incidents that have occurred in their projects. This brings learnings from the events and from general HSE work at the for departments at NTNU which are involved in SUBPRO:

- Department of Chemical Engineering.
- Department of Geoscience and Petroleum.
- Department of Mechanical and Industrial Engineering.
- Department of Engineering Cybernetics.

In case of a reported incident both the HSE engineer, and the Campus service office have the responsibility to follow up on the incident and to mitigate adequate measure- ments and solutions.

### HSE PROCEDURES FOR SUBPRO ACTIVITIES

All PhD students, Postdoctoral fellows and Master stu- dents who work in laboratory projects in SUBPRO receive a two-level safety training; basic HSE training and HSE training for specific equipment.

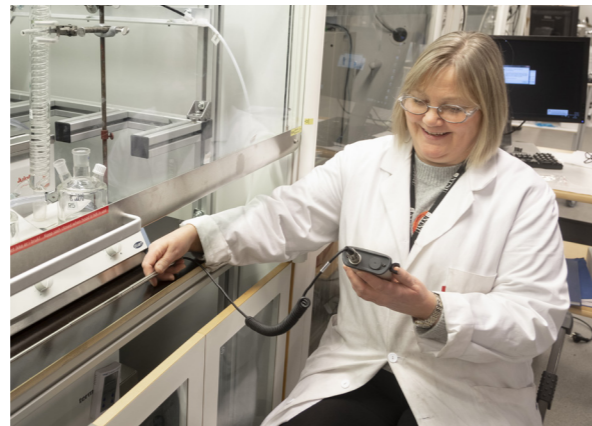

*Gunn Torill Wikdahl, Senior HSE Engineer at NTNU, inspecting an extractor hood in the laboratory*

SUBPRO follows NTNU's HSE system and reports possible events and mitigations to the SUBPRO Centre board twice a year.

From 2018 an annual HSE learning report has been dis- tributed to all personnel at SUBPRO who work in experi- mental projects. The report has also been distributed to the Centre board.

The industry partners have the right to visit the work sites whenever desired.

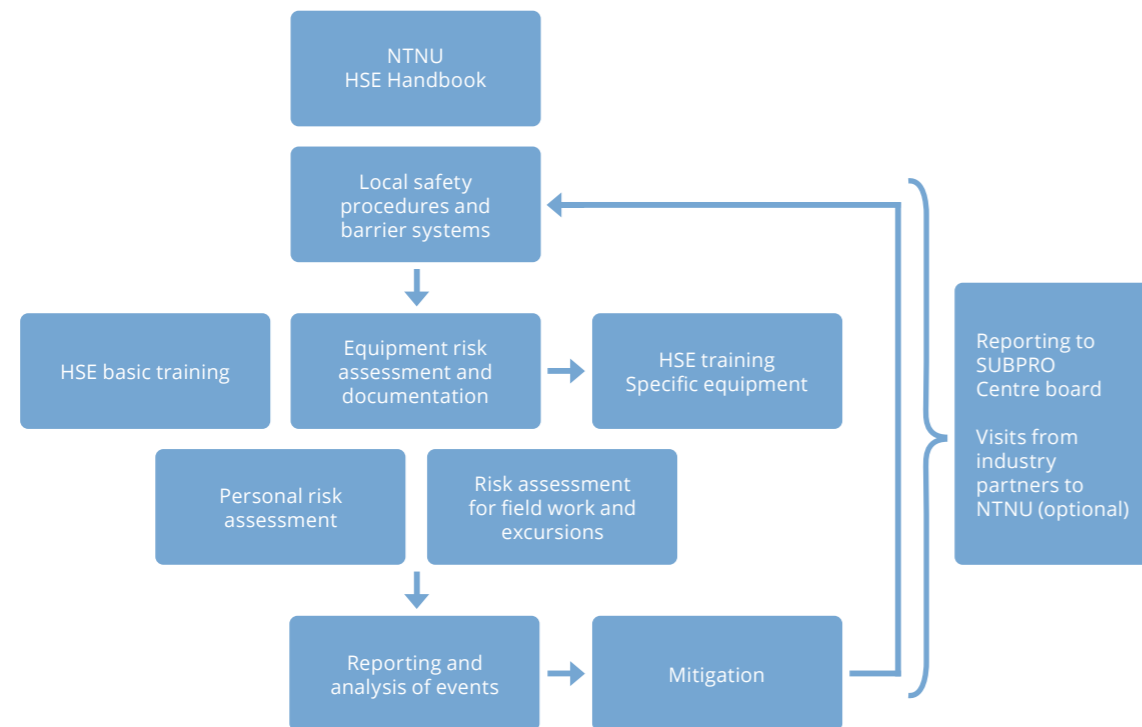

*Figure 1. NTNU/SUBPRO HSE system*

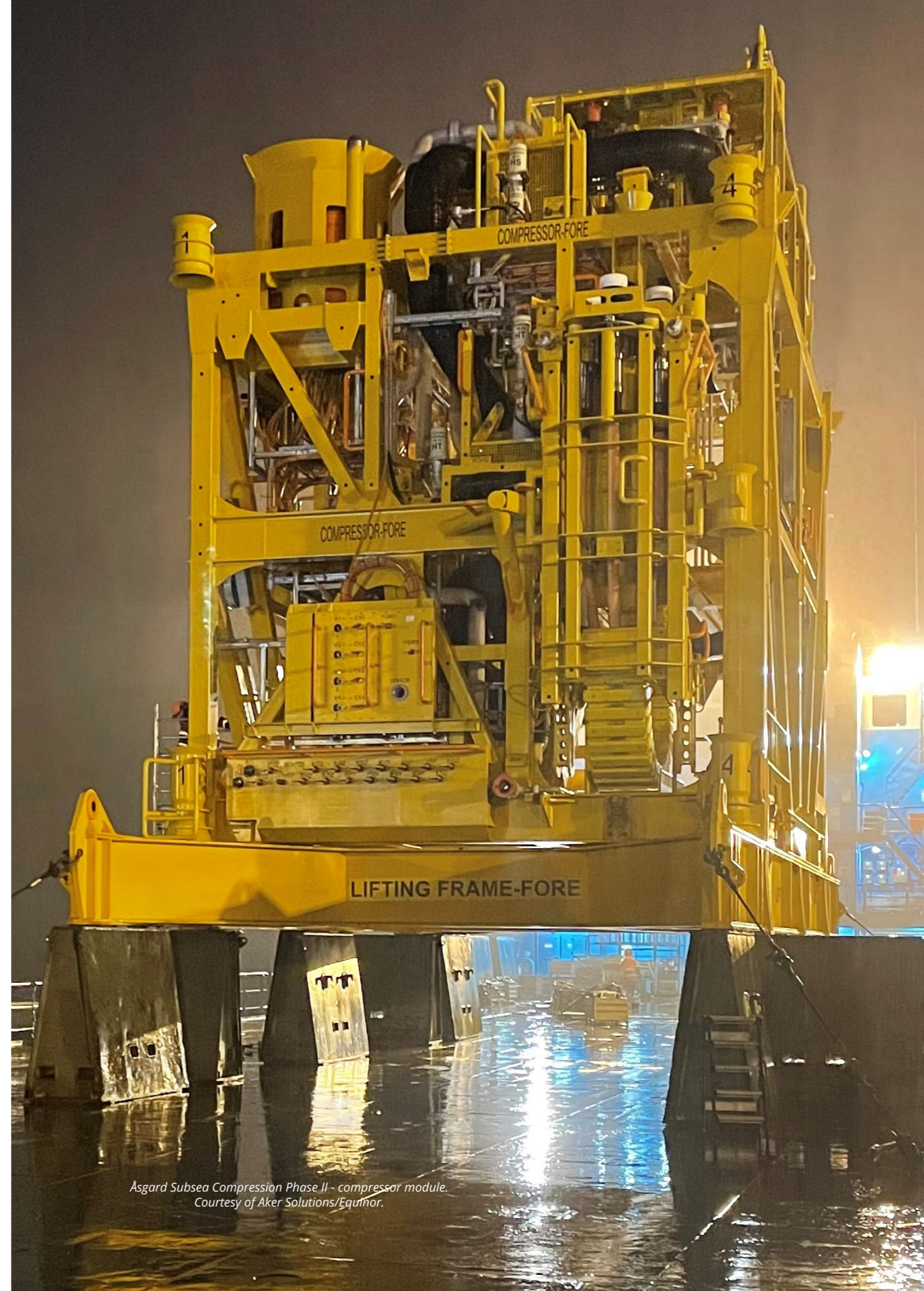

*Åsgard Subsea Compression Phase II - compressor module. Courtesy of Aker Solutions/Equinor.*



# Dissemination of Results

The results from the SUBPRO research projects have been disseminated to three main groups of users:

- Academia
- Subsea industry
- SUBPRO Industry partner

## ACADEMIA

SUPBRO has produced 189 journal papers and reviewed conference papers in renowned scientific journals and international conferences. SUBPRO researchers have given several keynote speeches and received many awards, as mentioned in connection with the various projects in this report. In several cases, representatives from the industry partners have been co-authoring the papers together with SUBPRO researchers.

A complete list of scientific journal publications within each Research Area can be found in the section «Publications» In this report.



PhD student Mehman Ahmadli presenting his project for a Reference Group meeting on Field Architecture.

## OFFSHORE INDUSTRY

Industry related results have been disseminated to the offshore industry through industrial conferences, like Subsea Valley, Underwater Technology Conference (UTC) and the Brazil-Norway Subsea Operations workshops in Brazil. In addition, and this is probably the most important means of dissemination and knowledge transfer, most of the graduated PhD and Postdoc candidates work in the offshore industry (see Table “Employment of PhD graduates of SUBPRO» page 70 of this report).

## SUBPRO INDUSTRY PARTNERS

Transfer of research results to the industry partners has been an essential goal for SUBPRO. We have established several arenas for such knowledge transfer and feedback, where not only the SUBPRO researchers, but also the industry partners have presented recent advances in knowledge and technology.

**Reference group meetings** have been arranged biannually within each Research Area to disseminate project results to the industry partners.

**Annual Technical Committee meetings** have reviewed new project results and given feedback from the industry partners to the researcher teams.

**A SUBPRO day** has been arranged annually to share project results across disciplines and research projects with the industry partners.

**Local project meetings and seminars** have been arranged with industry partners within specific topics.

Project results have also been shared through development and application of new technology in collaboration between research teams and industry partners.

**Sharepoint project result database.** The industry partners have had access to all technical reports and scientific papers through a Sharepoint database.



The System control team together with the Norwegian delegation at the DYCOPS conference in Florianopolis in Brazil - 2019

The annual reports of SUBPRO have been delivered yearly to the Research Council of Norway, the industry partners and other stakeholders. Eight editions in total, which all can be found on this link from the official webpage of SUBPRO: <https://www.ntnu.edu/subpro/aboutsubpro>

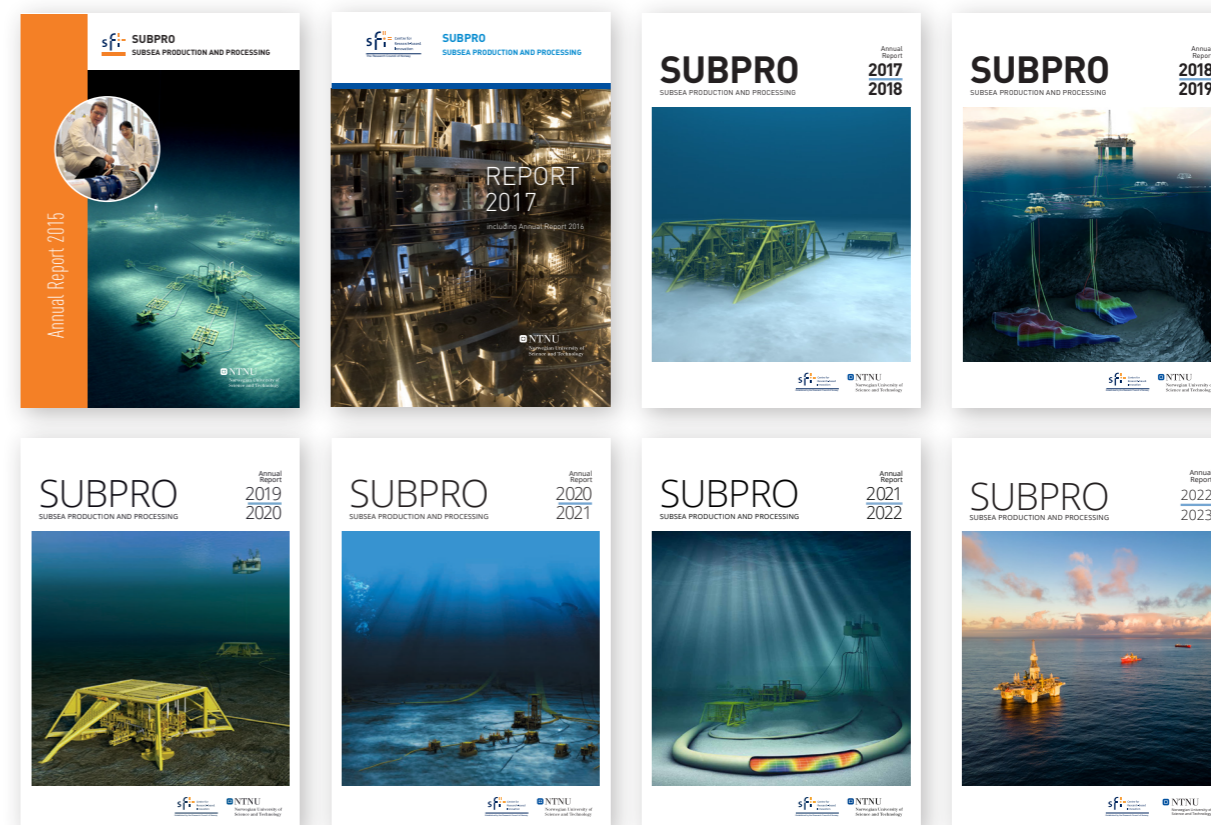



# Publications

## Journal and conference papers published from 2015 to 2023.

### FIELD ARCHITECTURE

**Ahmadli, M, Gjersvik, TB, & Sangesland, S.**

*“Design Assessment and Optimization of a Barrier Valve for Subsea Applications”.*

ASME 2023 42nd International Conference on Ocean, Offshore and Arctic Engineering (OMAE 2023); Volume 3: Materials Technology; Pipelines, Risers, and Subsea Systems; ISBN: 978-0-7918-8685-4; 8 pages; Melbourne, Australia; June 11–16, 2023.

**Ahmadli, M., Gjersvik, T. B., Sangesland, S., and C. Reynes.**

*“Analysis of All-Electric Subsea Gate Valve Designs and System Overview”.*

SPE Norway Subsurface Conference, Bergen, Norway, April 2024.

**Ahmadli, M, Gjersvik, TB, Sangesland, S, & Reynes, C.**

*“Enhancing Subsea Ball Valve Performance: A Material and Design Approach.”*

ASME 2024 43rd International Conference on Ocean, Offshore and Arctic Engineering; 2024.

**Diaz Arias, Mariana JC; Stanko, Milan; Sangesland, Sigbjørn.**

*“Exploring New Concepts in Subsea Field Architecture”.*

Offshore Technology Conference; 2018-04-30 - 2018-05-03.

**Diaz Arias, Mariana JC; Stanko, Milan; Sangesland, Sigbjørn.**

*“The subsea gate box: an alternative subsea field architecture”.*

SPE Norway the First Magazine; Vol 1 pp. 38-43-2018.

**Diaz Arias, Mariana JC; dos Santos, Allyne Machado; Altamiranda, Edmary.**

*“Evolutionary Algorithm to Support Field Architecture Scenario Screening Automation and Optimization Using Decentralized Subsea Processing Modules”.*

Proceses; Vol 9. (1); 2020.

**Gonzalez Rengifo, Diana Carolina; Stanko, Milan; Golan, Michael.**

*“Numerical Feasibility Study of a Wax Cold Flow Approach for Subsea Tie-In Flowlines Using a 1D Mechanistic Multiphase Flow Simulator”.*

Engineering; Vol 10. (3) pp. 109-123; 2018.

**Gonzalez Rengifo, Diana Carolina; Stanko, Milan; Golan, Michael.**

*“Numerical Feasibility Study of Electric Heating Strategies for Subsea Tie-In Flowlines Using a 1-D Mechanistic Multiphase Flow Simulator”.*

Engineering; Volume 10. (9) pp. 531-571; 2018.

**González, D., Stanko, M. & Hoffmann, A.**

*“Decision support method for early-phase design of offshore hydrocarbon fields using model-based optimization”.*

J Petrol Explor Prod Techno; Vol 10 pp. 1473–1495 ; 2019.

**Liu, Haoge; Gjersvik, Tor Berge; Faanes, Audun.**

*“Subsea field layout optimization (Part I) – directional well trajectory planning based on 3D Dubins Curve”.*

Journal of Petroleum Science and Engineering; Vol 208. (B); 2021.

**Liu, Haoge; Gjersvik, Tor Berge; Faanes, Audun.**

*“Subsea field layout optimization (part II)–the location-allocation problem of manifolds”.*

Journal of Petroleum Science and Engineering; Vol 208. (A); 2021.

**Liu, Haoge; Gjersvik, Tor Berge; Faanes, Audun.**

*“Subsea field layout optimization (part III) --- the location-allocation problem of drilling sites”.*

Journal of Petroleum Science and Engineering; Vol 208. (B); 2021.

**Nunez, Gilberto; De Andrade, Jesus; Stanko, Milan; Sangesland, Sigbjørn.**

*“Available technologies and performance prediction models for multiple boosting”.*

International Conference on advances in Subsea Engineering, Structures & Systems; (10pages). Glasgow, June 6 – 7, 2016.

**Sales, Leonardo de Pádua Agripa; Jäschke, Johannes; Stanko, Milan.**

*“Early field planning using optimization and considering uncertainties - Study case: Offshore deepwater field in Brazil”.*

Journal of Petroleum Science and Engineering; Vol 207; 2021.

**Sales, Leonardo; Jäschke, Johannes; Stanko, Milan.**

*“Designing Subsea Processing Systems Using a Hybrid Genetic Algorithm”.*

41st International Conference on Ocean, Offshore and Arctic Engineering (OMAE2022); Vol 1; 7 pages; (2022-06-05 - 2022-06-10).

**Sales, Leonardo; Jäschke, Johannes; Stanko, Milan.**

*“Superstructure optimization of subsea processing layouts”.*

Journal of Petroleum Exploration and Production Technology; Vol 13 pp. 1575- 1589; 2023.

**Sales, Leonardo; Thomas, Stolpnes; Stanko, Milan; Faanes, Audun.**

*“Subsea Processing Optimization Considering Reliability and Maintenance”.*

42nd International Conference on Ocean, Offshore and Arctic Engineering (OMAE2023); ISBN: 978-0-7918-8685-4; 9 pages; (2023-06-11 - 2023-06-16).

**Sevillano, Lucas Cantinelli; Sangesland, Sigbjørn; Gjersvik, Tor Berge; Faanes, Audun.**

*“Enabling technologies for low-cost subsea field development”.*

Proceedings of the ASME 2021 40th International Conference on Ocean, Offshore, and Arctic Engineering. Volume 4: Pipelines, Risers, and Subsea Systems. Virtual; Online. ISBN: 978-0-7918-8514-7; (June 21–30, 2021).

**Sevillano, Lucas Cantinelli; Sangesland, Sigbjørn; Gjersvik, Tor Berge; Faanes, Audun.**

*“A more accurate approach for the design of subsea chemical storage systems regarding volume requirements of valve leakage tests”.*

41st International Conference on Ocean, Offshore and Arctic Engineering (OMAE2022); ISBN: 978-0-7918-8595-6; 9 pages; (2022-06-05 - 2022-06-10).

### RELIABILITY, AVAILABILITY, MAINTENANCE AND SAFETY (RAMS)

**Alfarizi, Muhammad Gibran; Bikmukhametov, Timur; Stanko, Milan.**

*“Well Control Optimization in Waterflooding Using Genetic Algorithm Coupled with Artificial Neural Networks”.*

Journal of Upstream oil and gas technology; Vol 9; March 2022.

**Alfarizi, Muhammad Gibran; Tajiani, B; Vatn, Jørn; Yin, Shen.**

*“Optimized random forest model for remaining useful life prediction of experimental bearings”.*

IEEE Transactions on Industrial Informatics, Vol 19. (6) pp.7771-7779, 2023.

**Alfarizi, Muhammad Gibran; Ustolin, F; Vatn, Jørn; Yin, Shen; Paltrinieri, N.**

*“Towards accident prevention on liquid hydrogen: A data-driven approach for releases prediction”.*

Reliability Engineering & System Safety, Vol 236, 109276, 2023.

**Alfarizi, Muhammad Gibran; Vatn, Jørn; Yin, Shen.**

*“An extreme gradient boosting aided fault diagnosis approach: A case study of fuse test bench”.*

IEEE Transactions on Artificial Intelligence, 4. (4): 661-668, 2023.

**Björklund, Ludvig; Glaser, Markus; Skofteland, Gunleiv; Lundteigen, Mary Ann.**

*“A Comparison of Different Approaches for Verification and Validation of Software in Safety-critical Systems”.*

Proceedings of the 31st European Safety and Reliability Conference; ISBN 978-981-18-2016-8; p 2878-2885; 2021.

**Björklund, Ludvig; Lundteigen, Mary Ann; Imle, Sebastian; Glaser, Markus.**

*“Design of a digital twin of gate valves for partial stroke testing”.*

ESREL 2022; p 2578-2585; ISBN: 978-981-18-5183-4; (2022-08-28 - 2022-09-01).

**Björklund, Ludvig Jonathan; Haugen, Odd Ivar; Lundteigen, Mary Ann.**

*“Life-Cycle Considerations for Trusting a Digital Twin for Safety Demonstrations”.*

ESREL 2023; p 2534 – 2541; ISBN: 978-981-18-8071-1; (2023-09-03 - 2023-09-07).

**Kim, Hyungju; Lundteigen, Mary Ann; Hafver, Andreas; Pedersen, Frank Børre; Skofteland, Gunleiv.**

*“Application of System-Theoretic Process Analysis to the isolation of subsea wells: Opportunities and challenges of applying STPA to subsea operations”.*

Offshore Technology Conference; Vol 6 pp. 4351-4361; (2018-04-30 - 2018-05-03).

**Kim, Hyungju; Lundteigen, Mary Ann.; Hafver, Andreas; Pedersen, Frank Børre; Skofteland, Gunleiv; Holden, Christian; Ohrem, Sveinung.**

*“Application of systems-theoretic process analysis to a subsea gas compression system”.*

Safety and Reliability - Safe Societies in a Changing World -Proceedings of the 28th International European Safety and Reliability Conference; ESREL 2018; pp. 1467 – 1475; ISBN: 9781351174657; 2018, Trondheim, Norway.

**Kim, Hyungju; Lundteigen, Mary Ann; Hafver, Andreas; Pedersen, Frank Børre.**

*“Utilization of risk priority number to systems-theoretic process analysis: A practical solution to manage a large number of unsafe control actions and loss scenarios. Proceedings of the Institution of Mechanical Engineers”.*

Part O, Journal of risk and reliability; Vol 235. (1)- pp. 92-107; 2020.

**Lee, Tae Hwan; Skofteland, Gunleiv; Lundteigen, Mary Ann.**

*“Performance Management of Safety Instrumented Systems for Unmanned Facilities Using Machine Learning: Decision Support System for SIS”.*

Proceedings of the 31st European Safety and Reliability Conference; pp. 2878-2885; ISBN: 981-973-0000-00-0; Singapore; 2021.

**Liu, Jie; Liu, Yiliu; Yin, Shen; Vatn, Jørn.**

*“Evaluation of Remain Useful Life Prediction Models from a Resilience Perspective”.*

Proceedings of the 32nd European Safety and Reliability Conference; pp. 2734-2740; ISBN: 978-981-18-5183-4; Dublin, Ireland (ESREL 2022).

**Liu, Jie; Vatn, Jørn; Pedersen, Viggo Gabriel Borg; Yin, Shen; Tajiani, Bahareh.**

*“A comparison study for bearing remaining useful life prediction by using standard stochastic approach and digital twin”.*

International Journal of Reliability and Safety; Vol 17. (2) pp. 103-122; 2023.

**Liu, Jie; Xingheng, Liu, Jørn, Vatn; Shen, Yin.**

*“A generic framework for qualifications of digital twins in maintenance.”*

Journal of Automation and Intelligence; vol 2 pp. 196-203; 2023.

**Liu, Xingheng; Vatn, Jørn.**

*“Filtering Noisy Gamma Degradation Process: Genz Transform Versus Gibbs Sampler”.*

Proceedings of the 31st European Safety and Reliability Conference.



Research Publishing Services; ISBN 978-981-18-2016-8; pp. 109-115; 2021.

**Liu, Xingheng; Vatn, Jørn; Zhang, Aibo.**  
“Modeling subsea choke valve erosion with a production-driven shock-associated degradation process”.  
The 11th International Conference on Quality, Reliability, Risk, Maintenance, and Safety Engineering & The 4th International Conference on Reliability Systems Engineering; pp. 1718-1724; 2021.

**Liu, Xingheng; Assumpcao Matias, Jose Otavio; Jäschke, Johannes; Vatn, Jørn.**  
“Gibbs sampler for noisy Transformed Gamma process: Inference and remaining useful life estimation”.  
Reliability Engineering & System Safety; Vol 217. (108084); 2022.

**Liu, Xingheng; Vatn, Jørn.**  
“Erosion state estimation for subsea choke valves considering valve openings”.  
The 32nd European Safety and Reliability Conference; pp. 1243-1250; ISBN: 978-981-18-5183-4; 2022.

**Liu, Xingheng; Vatn, Jørn; Yin, Shen; Maithani, Vinay.**  
“Performance of ChatGPT on CMRP: Potential for Assisting Maintenance and Reliability Professionals Using Large Language Models”.  
IECON 2023- 49th Annual Conference of the IEEE Industrial Electronics Society; pp. 1-7; Singapore, 2023.

**Liu, Xingheng; Lunde, Erling; Diehl, Fabio; Zhang, Aibo; Vatn, Jørn; Yin, Shen.**  
“Degradation modeling under time-varying operating conditions: Inference and prognosis with particle filter”.  
Reliability Engineering & System Safety; Vol 245. (109965); 2024.

**Srivastav, Himanshu; de Azevedo Vale, Guilherme; Barros, Anne; Lundteigen, Mary Ann; Pedersen, Frank Børre; Hafver, Andreas; Oliveira, Luiz F.**  
“Optimization of periodic inspection time of SIS subject to a regular proof testing”.  
Safety and Reliability - Safe Societies in a Changing World - Proceedings of the 28th International European Safety and Reliability Conference; pp. 1125 – 1132; ISBN: 9781351174657; Trondheim, Norway; 2018.

**Srivastav, H.; Barros, A.& Lundteigen, M A.**  
“Modelling framework for performance analysis of SIS subject to degradation due to proof tests”.  
Reliability Engineering & System Safety; Vol 195. (106702) pp. 1-15; 2019.

**Srivastav, Himanshu; Lundteigen, Mary Ann; Barros, Anne.**  
“Introduction of degradation modeling in qualification of the novel subsea technology”.  
Reliability Engineering & System Safety; Vol 216; 2021.

**Zhang, Yun; Rauzy, Antoine; Barros, Anne; Lunde, Erling.**  
“A modelling methodology for the assessment of preventive maintenance on a compressor drive system”.

Safety and Reliability - Safe Societies in a Changing World - Proceedings of the 28th International European Safety and Reliability Conference; pp. 555 - 564; ISBN: 9781351174657; Trondheim, Norway; 2018.

**Zhang, Juntao; Liu, Yiliu; Lundteigen, Mary Ann; Bouil-laut, Laurent.**  
“Using Bayesian Networks to quantify the reliability of a subsea system in the early design”.  
Risk, Reliability and Safety: Innovating Theory and Practice: Proceedings of ESREL 2016; 404 – 411; ISBN: 978113802997; Glasgow, Scotland; (25-29 September 2016).

**Zhang, Juntao; Liu, Yiliu; Lundteigen, Mary Ann.**  
“Framing Reliability Specification in Early Design Phase of Subsea Systems”.  
Proceedings of the 23rd ISSAT International Conference on Reliability and Quality in Design; pp. 44 - 48; ISBN: 978-0-9910576-4-1; 2017.

**Zhang, Juntao; Haskins, Cecilia; Liu, Yiliu; Lundteigen, Mary Ann.**  
“A systems engineering-based approach for framing reliability, availability, and maintainability: A case study for subsea design”.  
Systems Engineering; Volume 21. (6) pp. 576-592; 2018.

**Zhang, Juntao; Kim, Hyungju.; Liu, Yiliu & Lundteigen, Mary Ann.**  
“Combining system-theoretic process analysis and availability assessment: A subsea case study. Proceedings of the Institution of Mechanical Engineers”.  
Part O, Journal of risk and reliability; Vol 233. (4) pp. 520-536; 2019.

**Zikrullah, Nanda Anugrah; Kim, Hyungju; Lundteigen, Mary Ann. & Van der Meulen, Meine J. P.**  
“Clarifying Implementation of Safe Design Principles in IEC 61508: Challenges of Novel Subsea Technology Development”.  
Proceedings of the 29th European Safety and Reliability Conference (ESREL); ISBN 978-981-11-2724-3; pp. 2928-2936; Hannover, Germany (22 - 26 September 2019).

**Zikrullah, Nanda Anugrah; van der Meulen, Meine J. P.; Kim, Hyungju & Lundteigen, Mary Ann.**  
“Clarifying Implementation of Safe Design Principles in IEC 61508: Challenges of Novel Subsea Technology Development”.  
29th European Safety and Reliability Conference; pp. 2928 – 2936; ISBN: 978-981-11-2724-3; 2019-09-22- 2019-09-26.

**Zikrullah, Nanda Anugrah; Kim, Hyungju; Van der Meulen, Meine J. P.; Skofteland, Gunleiv; Lundteigen, Mary Ann.**  
“A comparison of hazard analysis methods capability for safety requirements generation”.  
Proceedings of the Institution of Mechanical Engineers. Part O, Journal of risk and reliability; Vol 235. (6) pp. 1132-1153; 2021.

## SEPARATION – FLUID CHARACTERIZATION

**Assar, Moein; Grimes, Brian Arthur.**

“A new approach to analyze the equilibrium and transient behaviors of particulate systems and the subsequent application to multiphase fluid systems”.  
Chemical Engineering Research and Design; Volume 188; Page 1083-1096; 2022.

**Assar, Moein; Simon, Sebastien Charles Roger; Sørl-land, Geir; Grimes, Brian Arthur.**  
“A theoretical and experimental investigation of batch oil-water gravity separation”.  
Chemical engineering research & design; Vol 194 pp. 136-150; 2023.

**Assar, Moein; Grimes, Brian Arthur.**  
“Geometrically transformed spectral methods to solve partial differential equations in circular geometries, application for multi-phase flow”.  
Mathematics and Computers in Simulation; Vol 215; pp. 456-475; 2024.

**Azizov, Ilgar; Dudek, Marcin; Øye, Gisle.**  
“Emulsions in porous media from the perspective of produced water re-injection – A review”.  
Journal of Petroleum Science and Engineering; Vol 206 (117152); 2021.

**Azizov, Ilgar; Dudek, Marcin; Øye, Gisle.**  
“Studying droplet retention in porous media by novel microfluidic methods”.  
Chemical Engineering Science (CES); Vol 248; 2022.

**Bertheussen, Are; Simon, Sebastien Charles; Sjøblom, Johan.**  
“Equilibrium Partitioning of Naphthenic Acids and Bases and their Consequences on Interfacial Properties”.  
Colloids and Surfaces A: Physicochemical and Engineering Aspects; Vol 529 pp. 45-56; 2017.

**Bertheussen, Are; Simon, Sebastien Charles; Sjøblom, Johan.**  
“Equilibrium Partitioning of Naphthenic Acid Mixture, Part 1: Commercial Naphthenic Acid Mixture”.  
Energy & Fuels; Vol 32. (7) pp. 7519-7538; 2018.

**Bertheussen, Are; Simon, Sebastien Charles; Sjøblom, Johan.**  
“Equilibrium Partitioning of Naphthenic Acid Mixture Part 2: Crude Oil-Extracted Naphthenic Acids “.  
Energy & Fuels; Vol 32. (9) pp. 9142-9158; 2018.

**Dudek, Marcin; Kancir, Eugènie; Øye, Gisle.**  
“Influence of the Crude Oil and Water Compositions on the Quality of Synthetic Produced Water”.  
Energy & Fuels; Vol 31(4) pp. 3708-3716; 2017.

**Dudek, Marcin; Bertheussen, Are; Dumaire, Thomas; Øye, Gisle.**  
“Microfluidic tools for studying coalescence of crude oil droplets in produced water”.  
Chemical Engineering Science; Vol 191 pp. 448-458; 2018.

**Dudek, Marcin; Muijlwijk, Kelly; Schroën, Karin; Øye, Gisle.**  
“The effect of dissolved gas on coalescence of oil drops studied with microfluidics”.

Journal of Colloid and Interface Science; Vol 528 pp. 166-173; 2018.

**Dudek, Marcin; Øye, Gisle.**  
“Microfluidic Study on the Attachment of Crude Oil Droplets to Gas Bubbles”.  
Energy & Fuels; Vol 32. (10) pp. 10513-10521; 2018.

**Dudek, M.; Chicault, J. & Øye, G.**  
“Microfluidic Investigation of Crude Oil Droplet Coalescence: Effect of Oil/Water Composition and Droplet Aging”.  
Energy & Fuels; Vol 34 (5) pp. 1-11; 2019.

**Dudek, Marcin; Fernandes, Diana; Herø, Eirik Helno; Øye, Gisle.**  
“Microfluidic method for determining drop-drop coalescence and contact times in flow”.  
Colloids and Surfaces A: Physicochemical and Engineering Aspects; Vol 586 (124265); 2020.  
**Dudek, Marcin; Ullaland, Hanne Skudal; Wehrle, Amandine; Øye, Gisle.**  
“Microfluidic testing of flocculants for produced water treatment: Comparison with other methodologies”.  
Water Research X; Vol 9 pp. 1-11; 2020.

**Dudek, Marcin; Vik, Eilen Arctander; Aanesen, Svein Viggo; Øye, Gisle.**  
“Colloid chemistry and experimental techniques for understanding fundamental behavior of produced water in oil and gas production”.  
Advances in Colloid and Interface Science; Vol 276. (102105); 2020.

**Dudek, Marcin; Ruwoldt, Jost; Øye, Gisle.**  
“Characterization and assessment of wax and wax inhibitors systems in microfluidic oil-in-water coalescence experiments”.  
Colloids and Surfaces A: Physicochemical and Engineering Aspects; Vol 636. (128186); 2022.

**Piccioli, Martina; Aanesen, Svein Viggo; Zhao, He; Dudek, Marcin; Øye, Gisle.**  
“Gas Flotation of Petroleum Produced Water: A Review on Status, Fundamental Aspects, and Perspectives”.  
Energy & Fuels; Vol 34. (12) pp. 15579-15592; 2020.

**Piccioli, Martina; Gjelsten Larsen, Robert André; Dudek, Marcin Jan; Aanesen, Svein Viggo; Øye, Gisle.**  
“Combined Influence of High Pressure and High Temperature on the Removal of Crude Oil from Water during Laboratory-Scale Gas Flotation”.  
Energy & Fuels; Vol 37 pp. 5644-5651; 2023.

**Ruwoldt, Jost; Simon, Sebastien Charles; Norrman, Jens; Oschmann, Hans-Jörg; Sjøblom, Johan.**  
“Wax-Inhibitor Interactions Studied by Isothermal Titration Calorimetry and Effect of Wax Inhibitor on Wax Crystallization”.  
Energy & Fuels; Vol 31. (7) pp. 6838-3847; 2017.

**Ruwoldt, Jost; Kurniawan, Muh; Oschmann, Hans-Jörg.**  
“Non-linear dependency of wax appearance temperature on cooling rate”.  
Journal of Petroleum Science and Engineering; Vol 165 pp. 114-126; 2018.

**Ruwoldt, Jost; Subramanian, Sreedhar; Simon, Sebastien Charles; Oschmann, Hans-Jörg; Sjøblom, Johan.**

*“Asphaltene fractionation based on adsorption onto calcium carbonate: Part 3. Effect of asphaltenes on wax crystallization”.*

Colloids and Surfaces A: Physicochemical and Engineering Aspects; Vol 554 pp. 129-14; 2018.

**Ruwoldt, J.; Kurniawan, M.; Sørland, G.; Simon, S C. & Sjøblom, J.**

*“Influence of wax inhibitor molecular weight: Fractionation and effect on crystallization of polydisperse waxes”.*

Journal of Dispersion Science and Technology; Vol 41. (8) pp. 1201-1216; 2019.

**Ruwoldt, J.; Sørland, G.; Simon, S C.; Oschmann, H-J. & Sjøblom, J.**

*“Inhibitor-wax interactions and PPD effect on wax crystallization: New approaches for GC/MS and NMR, and comparison with DSC, CPM, and rheometry”.*

Journal of Petroleum Science and Engineering; Vol 177 pp. 53-68; 2019.

**Savulescu, George Claudiu; Simon, Sebastien Charles; Sørland, Geir; Øye, Gisle.**

*“New Nuclear Magnetic Resonance approaches on the evolution of wax mobility during wax crystallization”.*

Energy & Fuels ; Vol 36. (1) pp. 350-360 ; 2022.

**Savulescu, George Claudiu; Simon, Sebastien Charles; Sørland, Geir Humborstad; Øye, Gisle.**

*“Novel Nuclear Magnetic Resonance Techniques to Assess the Wax Precipitation Evolution in Crude Oil Systems”.*

Energy & Fuels ; Vol 37. (1) pp. 291-300 ; 2023.

**Savulescu, George Claudiu ; Simon, Sebastien Charles ; Sørland, Geir Humborstad; Øye, Gisle.**

*“Understanding the effect of asphaltenes and wax inhibitors on wax crystallization by improved NMR techniques”.*

Ind. Eng. Chem.Res; Vol 62. (44) pp. 18251-18262 ; 2023.

Savulescu, George Claudiu; Simon, Sebastien Charles; Øye, Gisle.

*“Alterations in paraffin wax crystal networks induced by asphaltenes and pour point depressants, investigated by atomic force microscopy”.*

Colloids and Surfaces A: Physicochemical and Engineering Aspects; Vol 691. (133843); 2024.

**Sjøblom, Johan; Mhatre, Sameer; Simon, Sebastien Charles; Skartlien, Roar; Sørland, Geir.**

*“Emulsions in external electric fields”.*

Advances in Colloid and Interface Science; Vol 294. (102455); 2021.

**Simon, Sebastien Charles; Ruwoldt, Jost; Sjøblom, Johan.**

*“A critical update of experimental techniques of bulk and interfacial components for fluid characterization with relevance to well fluid processing and transport”.*

Advances in Colloid and Interface Science; Vol 277. (102120); 2020.

**Skjefstad, Håvard Slettahjell; Dudek, Marcin; Øye, Gisle; Stanko, Milan.**

*“The effect of upstream inlet choking and surfactant addition on the performance of a novel parallel pipe oil-water separator”.*

Journal of Petroleum Science and Engineering; Vol 189. (106971); 2020.

## SEPARATION – PROCESS CONCEPTS

**Ahmadi, Mahdi; Janakiram, Saravanan; Dai, Zhongde; Ansaloni, Luca; Deng, Liyuan.**

*“Performance of mixed matrix membranes containing porous two-dimensional (2D) and three-dimensional (3D) fillers for CO<sub>2</sub> separation: A review”.*

Membranes; Vol 8:50. (3) pp. 1-46; 2018.

**Ahmadi, Mahdi; Lindbråthen, Arne; Hillestad, Magne; Deng, Liyuan.**

*“Subsea natural gas dehydration in a membrane contactor with turbulence promoter: An experimental and modeling study”.*

Chemical Engineering Journal; Vol 404. (126535); 2020.

**Ahmadi, Mahdi; Ansaloni, Luca; Hillestad, Magne; Deng, Liyuan.**

*“Solvent Regeneration by Thermopervaporation in Subsea Natural Gas Dehydration: An Experimental and Simulation Study”.*

Industrial Engineering Chemistry Research; Vol 60. (17) pp. 6262-6276; 2021.

**Asaadian, Hamidreza; Harstad, Sigurd; Stanko Wolf, Milan Edvard.**

*“Drainage Potential Curves of Single Tapping Point for Bulk Oil–Water Separation in Pipe”.*

Energies; Vol 15. (19); 6911; 2022.

**Asaadian, Hamidreza, Stanko, Milan.**

*“Experimental Characterization and Evaluation of Crude Spiking Influence on Oil/Water Dispersed Flow in Pipe”.*

Molecules; Vol 28. (17); 6363; 2023.

**Asaadian, Hamidreza, Stanko, Milan.**

*“Experimental quantification of the performance of a horizontal multi-pipe bulk separator of water and oil with crude spiking”.*

Journal of Petroleum Exploration and Production Technology, Vol 13. (11) pp. 2283-2302; 2023.

**Dalane, Kristin; Dai, Zhongde; Mogseth, Gro; Hillestad, Magne; Deng, Liyuan.**

*“Potential applications of Membrane Separation for Subsea Natural Gas Processing: A Review”.*

Journal of Natural Gas Science and Engineering; Vol 39 pp. 101-117; 2017.

**Dalane, Kristin; Svendsen, Hallvard Fjøsne; Hillestad, Magne; Deng, Liyuan.**

*“Membrane contactor for subsea natural gas dehydration: Model development and sensitivity study”.*

Journal of Membrane Science; Vol 556 pp. 263-276; 2018.

**Dalane, K.; Hillestad, M. & Deng, L.**

*“Subsea natural gas dehydration with membrane processes: Simulation and process optimization”.*

Chemical engineering research & design; Vol 142 pp. 257-267; 2019.

**Herø, E H.; La Forgia, N.; Solsvik, J. & Jakobsen, H A.**

*“Determination of Breakage Parameters in Turbulent Fluid-Fluid Breakage”.*

Chemical Engineering & Technology; Vol 42. (4). pp. 903-909; 2019.

**Herø, Eirik Helno; La Forgia, Nicolas; Solsvik, Jannike; Jakobsen, Hugo Atle.**

*“Single Drop Breakage in Turbulent Flow: Statistical Data Analysis”.*

Chemical Engineering Science: X; Vol 8. (100082) pp. 1-23; 2020.

**Herø, E. H., La Forgia, N., Solsvik, J., Jakobsen, H. A.**

*“Single oil drop breakage in water: Impact of turbulence level in channel flow”.*

Chemical Engineering Science: X, Vol 12. (100111) pp. 1-26; ISSN: 2590-1400; 2021.

**Karbas Foroushan, Hanieh; Jakobsen, Hugo Atle.**

*“On the dynamics of fluid particle breakage induced by hydrodynamic instabilities: A review of modelling approaches”.*

Chemical Engineering Science (CES); Vol 219 pp. 1-20; 2020.

**Karbas Foroushan, Hanieh; Jakobsen, Hugo Atle.**

*“On the Instability of Fluid Particle Interface and Shape Oscillations”.*

International Journal of Multiphase Flow; Vol 136 pp. 1-32; 2020.

**Karbas Foroushan, Hanieh.; Lunde, Bjørnar; Ytrehus, Jan David; Saasen, Arild.**

*“Cement Placement: An Overview of Fluid Displacement Techniques and Modelling”.*

Energies; Vol 14. (3) pp. 1-33; 2021.

**La Forgia, Nicolas; Herø, Eirik Helno; Solsvik, Jannike; Jakobsen, Hugo Atle.**

*“Dissipation rate estimation in a rectangular shaped test section with periodic structure at the walls”.*

Chemical Engineering Science; Vol 195 pp. 159-178; 2018.

**La Forgia, N., Herø, E. H., Jakobsen, H. A.**

*“High-speed image processing of fluid particle breakage in turbulent flow”.*

Chem Eng Sci: X; Vol 12 pp. 1-21; 100117 2021.

**Limpach, Juliette M., Pinto, Diego Di Domenico, Knuutila, Hanna K.**

*“Heat Integration Study of CO<sub>2</sub> Capture in Blue Hydrogen Production”.*

Chemical Engineering transactions; Vol 99 pp. 373; 2023.

**Diego Di. Pinto, Juliette M. Limpach, Hanna K. Knuutila,**

*“Simulation-based assessment of the potential of offshore blue hydrogen production with high CO<sub>2</sub> capture rates with optimized heat recovery”*

Gas Science and Engineering, Vol 121. (205177); 2024.

**Skjefstad, Håvard Slettahjell; Stanko, Milan.**

*“Subsea Water Separation: A State-of-the-Art Review, Future Technologies and the Development of a Compact Separator Test Facility”.*

18th International Conference on Multiphase Technology (7-9 June 2017).

**Skjefstad, Håvard Slettahjell; Stanko, Milan.**

*“An Experimental Study of a Novel Parallel Pipe Separator Design for Subsea Oil-Water Bulk Separation”.*

SPE Asia Pacific Oil & Gas Conference and Exhibition; (2018-10-23 - 2018-10-25).

**Skjefstad, Håvard Slettahjell; Stanko, Milan.**

*“Experimental performance evaluation and design optimization of a horizontal multi-pipe separator for subsea oil-water bulk separation”.*

Journal of Petroleum Science and Engineering; Vol 176 pp. 203-219; 2019.

**Skylogianni, E. & Knuutila, H K.**

*“Process Intensification: H<sub>2</sub>S and Hydrate Control for Subsea Application”.*

GPA Europe Spring Conference (2019); (2019-05-14 - 2019-05-17).

**Skylogianni, E.; Wanderley, R R.; Austad, S S. & Knuutila, H K.**

*“Density and Viscosity of the Nonaqueous and Aqueous Mixtures of Methyl-diethanolamine and Monoethylene Glycol at Temperatures 3 from 283.15 to 353.15 K”.*

Journal of Chemical and Engineering Data; November; Vol 64. (12) pp. 5415-5431; 2019.

**Skylogianni, Eirini; Mundal, Ingvild; Pinto, Diego Di Domenico; Coquelet, Christophe; Knuutila, Hanna K.**

*“Hydrogen Sulfide Solubility in 50 wt.% and 70 wt.% Aqueous Methyl-diethanolamine at Temperatures from 283 to 393 K and Total Pressures from 500 to 10000 kPa”.*

Fluid Phase Equilibria; Vol 511; 112498; 2020.

**Skylogianni, Eirini; Perinu, Cristina; Cervantes Gameros, Blanca Y; Knuutila, Hanna K.**

*“Carbon dioxide solubility in mixtures of methyl-diethanolamine with monoethylene glycol, monoethylene glycol–water, water and triethylene glycol”.*

Journal of Chemical Thermodynamics; Vol 151 pp. 1-19; 2020.

**Stanko, Milan.**

*“Observations on and use of curves of current dimensionless potential versus recovery factor calculated from models of hydrocarbon production systems”.*

Journal of Petroleum Science and Engineering; Volume 196; 108014; ISSN 0920-4105, 2021.

## SYSTEM CONTROL

**Assumpcao Matias, Jose Otavio; Le Roux, Galo AC; Jaeschke, Johannes.**

*“Modifier adaptation for real-time optimization of a gas lifted well network”.*

IFAC-PapersOnLine; Vol 51. (8) pp. 31-36; 2018.

**Assumpcao Matias, J O.& Jäschke, J.**



*“Using a neural network for estimating plant gradients in real-time optimization with modifier adaptation”.*  
IFAC-PapersOnLine; Vol. 52 (1) pp. 808-813; 2019.

**Assumpcao Matias, J O. & Jäschke, J.**  
*“Online Model Maintenance via Output Modifier Adaptation”.*  
Industrial & Engineering Chemistry Research; Vol. 58 (30) pp. 13750-13766; 2019.

**Assumpcao Matias, Jose Otavio; Jäschke, Johannes.**  
*“Online Model Maintenance in Real-time Optimization Methods”.*  
Computers and Chemical Engineering; Vol 145 pp. 1-17; 2020.

**Assumpcao Matias, Jose Otavio; Ågotnes, Joachim Alexander Hauge; Jäschke, Johannes.**  
*“Health-aware advanced control applied to a gas-lifted oil well network”.*  
IFAC-PapersOnLine; Vol 53. (3) pp. 301-306; 2020.

**Assumpcao Matias, Jose Otavio; de Castro Oliveira, Julio Paez; Le Roux, Galo A. C.; Jäschke, Johannes.**  
*“Real-time optimization with persistent parameter adaptation applied to experimental rig”.*  
IFAC-PapersOnLine; Vol 54. (3) pp. 475-480; 2021.

**Assumpcao Matias, Jose Otavio; Jäschke, Johannes.**  
*“From-scratch development and improvement of a problem-based learning course: Nonlinear Model Predictive Control for Chemical and Biochemical Processes”.*  
IFAC-Papers Online ; Vol 55 ; pp. 174-179 ; 2022.

**Assumpcao Matias, Jose Otavio; Myrvang, Frida Bakken; Jäschke, Johannes.**  
*“Implementation of Extremum Seeking Control in an Experimental Lab-Rig”.*  
IFAC-PapersOnLine; pp. 137-142; 2022.

**Assumpcao Matias, Jose Otavio; Oliveira, Julio P.C.; Le Roux, Galo A. C.; Jäschke, Johannes.**  
*“Steady-state real-time optimization using transient measurements on an experimental rig”.*  
Journal of Process Control; Vol 115 pp. 181-196; 2022.

**Assumpcao Matias, Jose Otavio; Yemane Ghebredngl, Salmon; Jäschke, Johannes.**  
*“Health-aware control using hybrid models applied to a gas-lifted oil well network”.*  
Computer-aided chemical engineering; pp. 1135-1140; 2022.

**Backi, Christoph Josef; Gravdahl, Jan Tommy; Skogestad, Sigurd.**  
*“Robust control of a two-state Greitzer compressor model by state-feedback linearization”.*  
IEEE Multi-Conference on Systems and Control. Buenos Aires; pp. 1226-1231; 2016.

**Backi, Christoph Josef; Skogestad, Sigurd.**  
*“A Simple Dynamic Gravity Separator Model for Separation Efficiency Evaluation Incorporating Level and Pressure Control”.*  
American Control Conference; pp. 2823 – 2828; Seattle, USA; (24-26 May 2017).

**Backi, Christoph Josef; Skogestad, Sigurd.**  
*“Virtual Inflow Monitoring for a Three-Phase Gravity Separator”.*  
IEEE Conference on Control Technology and Applications (CCTA); pp. 1499-1504; ISBN: 978-1-5090-2182-6; 2017.

**Backi, Christoph Josef; Gravdahl, Jan Tommy; Skogestad, Sigurd.**  
*“Simple method for parameter identification of a nonlinear Greitzer compressor model”.*  
IFAC-PapersOnLine; Vol 51. (13) pp. 198-203; 2018.

**Backi, Christoph Josef; Grimes, Brian Arthur; Skogestad, Sigurd.**  
*“A Control- and Estimation-Oriented Gravity Separator Model for Oil and Gas Applications Based upon First-Principles”.*  
Industrial & Engineering Chemistry Research; Vol 57. (21) pp. 7201-7217; 2018.

**Backi, Christoph Josef; Krishnamoorthy, Dinesh; Skogestad, Sigurd.**  
*“Slug handling with a virtual harp based on nonlinear predictive control for a gravity separator”.*  
IFAC-PapersOnLine; Volume 51. (8) pp. 120-125; 2018.

**Backi, Christoph Josef; Krishnamoorthy, Dinesh; Verheyleweghen, Adriaen; Skogestad, Sigurd.**  
*“Combined nonlinear moving horizon estimation and model predictive control applied to a compressor for active surge control”.*  
2nd IEEE Conference on Control Technology and Applications; pp. 1552-1557; (2018-08-21 - 2018-08-24).

**Backi, Christoph Josef; Skogestad, Sigurd.**  
*“Virtual inflow estimation with simplified tuning using cascaded and Kalman-like least squares observers”.*  
Computer-aided chemical engineering; Vol 43 pp. 1153-1158; 2018.

**Backi, C J.; Emebu, S.; Skogestad, S. & Grimes, B A.**  
*“A simple modeling approach to control emulsion layers in gravity separators”.*  
Computer-aided chemical engineering; Vol 46 pp. 1159-1164; 2019.

**Backi, Christoph Josef; Gravdahl, Jan Tommy; Skogestad, Sigurd.**  
*“Combined state and parameter estimation for not fully observable dynamic systems”.*  
IFAC Journal of Systems and Control; Vol 13; 2020.

**Bikmukhametov, Timur; Milan Stanko, Johannes Jäschke.**  
*“Statistical Analysis of Effect of Sensor Degradation and Heat Transfer Modeling on Multiphase Flowrate Estimates from a Virtual Flow Meter”.*  
SPE Asia Pacific Oil and Gas Conference and Exhibition, Brisbane, Australia; ISBN: 978-1-61399-595-2; SPE 191962; (23-25 October 2018).

**Bikmukhametov, T. & Jäschke, J.**  
*“First Principles and Machine Learning Virtual Flow Metering: A Literature Review”.*  
Journal of Petroleum Science and Engineering; Vol 184. (106487) pp. 1-26; 2019.

**Bikmukhametov, T. & Jäschke, J.**  
*“Oil Production Monitoring using Gradient Boosting Machine Learning Algorithm”.*  
IFAC-PapersOnLine; Vol 52. (1) pp. 514-519; 2019.

**Bikmukhametov, Timur; Jäschke, Johannes.**  
*“Combining machine learning and process engineering physics towards enhanced accuracy and explainability of data-driven models”.*  
Computers and Chemical Engineering; Vol 138 pp. 1-27; 2020.

**Bonnowitz, Harro; Straus, Julian; Krishnamoorthy, Dinesh; Jahanshahi, Esmaeil; Skogestad, Sigurd.**  
*“Control of Steady-state Gradient of an Ammonia Reactor using Transient Measurements”.*  
Computer-aided chemical engineering; Vol 43 pp. 1111-1116; 2018.

**Das, Tamal; Backi, Christoph Josef; Jäschke, Johannes.**  
*“A Model for Subsea Oil-Water Gravity Separator to Estimate Un-measured Disturbances”.*  
Computer-aided chemical engineering; Vol 40 pp. 1489-1494; 2017.

**Das, Tamal; Jäschke, Johannes.**  
*“Modeling and control of an inline deoiling hydrocyclone”.*  
IFAC-PapersOnLine; Vol 51. (8) pp. 138-143; ISSN 2405-8963. 2018.

**Das, T.; Heggheim, S J.; Dudek, M.; Verheyleweghen, A. & Jäschke, J.**  
*“Optimal Operation of a Subsea Separation System Including a Coalescence Based Gravity Separator Model and a Produced Water Treatment Section”.*  
Industrial & Engineering Chemistry Research; Vol 58. (10) pp. 4168-4185; 2019.

**Dirza, Risvan; Skogestad, Sigurd; Krishnamoorthy, Dinesh.**  
*“Optimal Resource Allocation using Distributed Feedback-based Real-time Optimization”.*  
IFAC-PapersOnLine; Vol 54. (3) pp. 706-711; 2021.

**Dirza, Risvan; Skogestad, Sigurd; Krishnamoorthy, Dinesh.**  
*“Real-Time Optimal Resource Allocation and Constraint Negotiation Applied to A Subsea Oil Production Network”.*  
Society of Petroleum Engineers; ISBN 978-1-61399-786-4; 18 pages; 2021.

**Dirza, Risvan; Krishnamoorthy, Dinesh; Skogestad, Sigurd.**  
*“Primal-dual Feedback-optimizing Control with Direct Constraint Control”.*  
Computer-aided chemical engineering; Vol 49 pp. 1153-1158; 2022.

**Dirza, Risvan; Rizwan, Md; Skogestad, Sigurd; Krishnamoorthy, Dinesh.**  
*“Real-time Optimal Resource Allocation using Online Primal Decomposition”.*  
IFAC-Papers Online ; Vol 55 pp. 31-36 ; 2022.

**Dirza, Risvan; Skogestad, Sigurd.**  
*“Online Feedback-based Optimization with Multi-input Direct Constraint Control”.*  
IFAC-Papers Online ; Vol 55 pp. 149-154 ; 2022.

**Dirza, Risvan; Skogestad, Sigurd.**  
*“Systematic Pairing Selection for Economic-oriented Constraint Control”.*  
Computer-aided chemical engineering; Vol 51 pp. 1249-1254; 2022.

**Jahanshahi, Esmaeil; Backi, Christoph Josef; Skogestad, Sigurd.**  
*“Anti-slug control based on a virtual flow measurement”.*  
Flow Measurement and Instrumentation; Vol 53. (Part B) pp.299-307; March 2017.

**Jahanshahi, E.; Krishnamoorthy, D.; Cudas, A.; Foss, B. & Skogestad, S.**  
*“Plantwide control of an oil production network”.*  
Comput. & Chem. Eng; Vol 136. (106765); 2019.

**Krishnamoorthy, Dinesh; Foss, Bjarne; Skogestad, Sigurd.**  
*“Real-Time Optimization under Uncertainty Applied to a Gas Lifted Well”.*  
Network. Processes; Vol 4. (529); 2016.

**Krishnamoorthy, Dinesh; Foss, Bjarne Anton; Skogestad, Sigurd.**  
*“Gas Lift Optimization under Uncertainty”.*

**Krishnamoorthy, Dinesh; Aguiar, Marco Aurelio; Foss, Bjarne Anton; Skogestad, Sigurd.**  
*“A Distributed Optimization Strategy for Large Scale Oil and Gas Production Systems”.*  
Proceedings of the IEEE Conference on Control Applications; pp. 521-526; 2018.

**Krishnamoorthy, Dinesh; Foss, Bjarne Anton; Skogestad, Sigurd.**  
*“A Distributed Algorithm for Scenario-based Model Predictive Control using Primal Decomposition”.*  
IFAC-PapersOnLine; Vol 51. (18) pp. 351-356; 2018.

**Krishnamoorthy, Dinesh; Foss, Bjarne Anton; Skogestad, Sigurd.**  
*“Steady-State Real-time Optimization using Transient Measurements”.*  
Computers and Chemical Engineering; Vol 115 pp. 34-45; 2018.

**Krishnamoorthy, Dinesh; Jahanshahi, Esmaeil; Skogestad, Sigurd.**  
*“Gas-lift Optimization by Controlling Marginal Gas-Oil Ratio using Transient Measurements”.*  
IFAC-PapersOnLine Volume 51. (8) pp. 19-24; 2018.

**Krishnamoorthy, Dinesh; Suwartadi, Eka; Foss, Bjarne Anton; Skogestad, Sigurd; Jäschke, Johannes.**  
*“Improving Scenario Decomposition for Multistage MPC using a Sensitivity-based Path-following Algorithm”.*

Proceedings of the IEEE Conference on Decision & Control, including the Symposium on Adaptive Processes; Vol 2 pp. 581-586; 2018.

**Krishnamoorthy, Dinesh; Suwartadi, Eka; Foss, Bjarne Anton; Skogestad, Sigurd; Jäschke, Johannes.**

*“Improving Scenario Decomposition for Multistage MPC using a Sensitivity-based Path-following Algorithm”.*  
IEEE Control Systems Letters; Vol 2. (4) pp. 581-586; 2018.

**Krishnamoorthy, Dinesh; Thombre, Mandar; Skogestad, Sigurd; Jäschke, Johannes.**

*“Data-driven Scenario Selection for Multi-stage Robust Model Predictive Control”.*  
IFAC-PapersOnLine; Vol 51. (20) pp. 462-468; 2018.

**Krishnamoorthy, D.; Fjalestad, K. & Skogestad, S.**

*“Optimal Control of offshore oil and gas production using simple feedback controllers”.*  
Control Engineering Practice; Vol 91. (104107); 2019.

**Krishnamoorthy, D.; Foss, B. & Skogestad, S.**

*“A Primal decomposition algorithm for distributed multistage scenario model predictive control”.*  
J. Proc. Control; Vol 81 pp. 162-171; 2019.

**Krishnamoorthy, D.; Jahanshahi, E. & Skogestad, S.**

*“A feedback Real time optimization strategy applied to an evaporator process”.*  
PSE Asia; Bangkok, Thailand; 2019.

**Krishnamoorthy, D.; Jahanshahi, E. & Skogestad, S.,**

*“A feedback RTO strategy using Transient Measurements”.*  
Ind. Eng; Chem. Res; Vol 58. (1) pp. 207-216; 2019.

**Krishnamoorthy, D.; Jäschke, J & Skogestad, S.**

*“Multistage Model Predictive Control with Online Scenario Tree Update using Recursive Bayesian Weighting”.*  
Proceedings of the 18th European Control Conference; pp. 1443-1448; 2019.

**Krishnamoorthy, D.; Ryu, J. & Skogestad, S.**

*“Dynamic extremum seeking control applied to a gas lifted well network”.*  
IFAC-Papers Online; Vol 52. (1) pp. 802-807; 2019.

**Krishnamoorthy, D. & Skogestad, S.**

*“Online process optimization with changes in active constraint sets using simple feedback control structures”.*  
Ind. Eng. Chem. Res; Vol 58. (30) pp. 13555-13567; 2019.

**Krishnamoorthy, Dinesh; Biegler, Lorenz T.; Jäschke, Johannes.**

*“Adaptive horizon economic nonlinear model predictive control”.*  
Journal of Process Control; Vol 92 pp. 100-118; 2020.

**Krishnamoorthy, Dinesh; Valli, Carlo; Skogestad, Sigurd.**

*“Real-time Optimal Resource Allocation in an Industrial Symbiotic Network using Transient Measurements”.*  
Proceedings of the American Control Conference; Vol 58 pp. 3541- 3546; 2020.

**Kristoffersen, Torstein Thode; Holden, Christian.**

*“Model Predictive Control and Extended Kalman Filter for a Gas-Liquid Cylindrical Cyclone”.* IEEE Conference on Control Technology and Applications (CCTA); ISBN: 978-1-5090-2182-6; pp. 1248 – 1255; 2017.

**Kristoffersen, Torstein Thode; Holden, Christian.**

*“Nonlinear Model Predictive Control of a Gas-Liquid Cylindrical Cyclone”.*  
25th Mediterranean Conference on Control and Automation; Vol 1. (17) Pp. 66-73; (3-6 June 2017).

**Kristoffersen, Torstein Thode; Holden, Christian; Egeland, Olav.**

*“Feedback Linearizing Control of a Gas-Liquid Cylindrical Cyclone”.*  
IFAC-PapersOnLine; Vol 50. (1) pp. 13121-13128; 2017.

**Kristoffersen, Torstein Thode; Holden, Christian; Skogestad, Sigurd; Egeland, Olav.**

*“Control-Oriented Modelling of Gas- Liquid Cylindrical Cyclones”.*  
American Control Conference (ACC); pp. 2829-2836; (24-26 May 2017).

**Kristoffersen, Torstein Thode; Holden, Christian.**

*“Modelling and nonlinear control of a wet gas centrifugal compressor”.*  
IEEE Conference on Control Technology and Applications; pp. 545-552; ISBN: 978-1-5386-7698-; (2018-08-21- 2018-08-24).

**Kristoffersen, Torstein Thode; Holden, Christian.**

*“Nonlinear state and parameter estimation of a gas-liquid cylindrical cyclone”.*  
IEEE Conference on Control Technology and Applications; pp. 1772-1778; ISBN: 978-1-5386-7698-1; (2018-08-21 - 2018-08-24).

**Kristoffersen, Torstein Thode; Holden, Christian.**

*“State and parameter estimation of a gas-liquid cylindrical cyclone”.*  
European Control Conference; pp. 2318 – 2325; ISBN: 978-3-9524-2698-2; (2018-06-12 - 2018-06-15).

**Kristoffersen, T. T. & Holden, C.**

*“A high-gain observer for a wet gas centrifugal compressor”.*  
IFAC -PapersOnLine; Vol 52. (16) pp. 442-447; 2019.

**Krog, Halvor Aarnes; Jäschke, Johannes.**

*“Systematic Estimation of Noise Statistics for Nonlinear Kalman Filters”.*  
IFAC-PapersOnLine; 2022.

**Krog, Halvor Aarnes; Jäschke, Johannes.**

*„The Simple Solution for Nonlinear State Estimation of III-Conditioned Systems: The Normalized Unscented Kalman Filter”.*  
IFAC-PapersOnLine, 56. (2) pp. 5951-5956; 2023.

**Kulangarakalam Gayathrivallabh, Mishiga Vallabhan; Holden, Christian.**

*“Non-linear control algorithms for de-oiling hydrocyclones”.*  
I: 28th Mediterranean Conference on Control and Automation (MED) proceedings; IEEE ISBN 978-1-7281- 5742-9; 2020.

**Kulangarakalam Gayathrivallabh, Mishiga Vallabhan; Holden, Christian; Skogestad, Sigurd.**

*“A First-Principles Approach for Control-Oriented Modeling of De-oiling Hydrocyclones”.*  
Industrial & Engineering Chemistry Research; Vol 59 pp .18937-18950; 2020.

**Kulangarakalam Gayathrivallabh, Mishiga Vallabhan; Assumpcao Matias, Jose Otavio; Holden, Christian.**

*“Feedforward, Cascade and Model Predictive Control Algorithms for De-Oiling Hydrocyclones: Simulation Study”.*  
Modeling, Identification and Control; Vol 42. (4) pp. 185-195; 2021.

**Kulangarakalam Gayathrivallabh, Mishiga Vallabhan; Dudek, Marcin; Holden, Christian.**

*“Experimental Test Setup for Deoiling Hydrocyclones Using Conventional Pressure Drop Ratio Control”.*  
SPE Production & Operations ; Vol 37 pp. 218-229 ; 2022.

**Ohrem, Sveinung Johan; Holden, Christian.**

*“Modeling and Nonlinear Model Predictive Control of a Subsea Pump Station”.*  
Control Conference Africa; vol 50. (2) pp. 121-126; (7-8 December 2017).

**Ohrem, Sveinung Johan; Holden, Christian; Jahanshahi, Esmaeil; Skogestad, Sigurd.**

*“L1 Adaptive Anti-Slug Control”.*  
American Control Conference (ACC); pp. 444-449; (24-25 April 2017).

**Ohrem, Sveinung Johan; Kristoffersen, Torstein Thode; Holden, Christian.**

*“Adaptive Feedback Linearizing Control of a Gas Liquid Cylindrical Cyclone”.*  
IEEE Conference on Control Technology and Applications (CCTA); pp. 1981-1987; ISBN: 978-1-5090-2182-6; 2017.

**Ohrem, Sveinung Johan; Holden, Christian.**

*“Controller and observer design for first order LTI systems with unknown dynamics”.*  
Proceedings of the 6th International Conference on Control, Mechatronics and Automation; pp. 29-34; ISBN: 978-1-4503-6563-5; 2018.

**Ohrem, Sveinung Johan; Kristoffersen, Torstein Thode; Holden, Christian.**

*“Model-Based and Model-Free Optimal Control of a Gas Liquid Cylindrical Cyclone”.*  
IFAC-Papers Online; Vol 51. (8) pp. 113-119; 2018.

**Ohrem, S.J.; Skjefstad, H S.; Stanko, M. & Holden, C.**

*“ Controller Design and Control Structure Analysis for a Novel Oil–Water Multi-Pipe Separator”.*  
Processes; Vol 7. (4) pp. 1-24; 2019.

**Ohrem, Sveinung Johan; Holden, Christian.**

*“Adaptive controller and observer design using open and closed-loop reference models for linear time-invariant systems with unknown dynamics”.*  
IEEE Transactions on Automatic Control; Vol 66. (11) pp. 5482-5489; 2021.

**Turan, Evren Mert; Jäschke, Johannes.**

*“Multiple shooting for training neural differential equations on time series”.*  
American Control Conference; Vol 6 pp. 1897-1902; (2022-06-08 - 2022-06-10).

**Turan, Evren Mert; Jäschke, Johannes.**

*“Designing neural network control policies under parametric uncertainty: A Koopman operator approach”.*  
IFAC-Papers Online ; Vol 55 pp. 392-399 ; 2022.

**Turan, Evren Mert; Kannan, Rohit; Jäschke, Johannes.**

*“Design of PID controllers using semi-infinite programming”.*  
Computer-aided chemical engineering 2022; Vol 49 pp. 439-444; 2022.

**Verheyleweghen, Adriaen; Jäschke, Johannes.**

*“Framework for Combined Diagnostics, Prognostics and Optimal Operation of a Subsea Gas Compression System”.*  
IFAC-PapersOnLine; Vol 50. (1) pp. 15916-15921; 2017.

**Verheyleweghen, Adriaen; Johannes Jäschke.**

*“Oil production optimization of several wells subject to choke degradation”.*  
IFAC-Papers Online; Vol 51. (8) pp. 1-6; ISSN 2405-8963; 2018.

**Verheyleweghen, A.; Srivastav, H.; Barros, A. & Jäschke, J.**

*“Combined Maintenance Scheduling and Production Optimization”.*  
Proceedings of the 29th European Safety and Reliability Conference ESREL; pp. 499-507; ISBN: 978-981-11-2724-3; (2019-09-23 - 2019-09-26).



# People in SUBPRO

## CHAIRMEN OF THE BOARD



Audun Faanes,  
Leading Engineer  
Subsea Technology,  
Equinor  
2015-2017

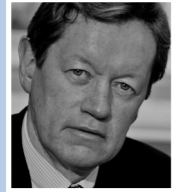

Stig Lyder Støme  
Chief Subsea  
Engineer  
Lundin Norway  
2017-2019



Frank Børre  
Pedersen  
Vice President and  
Programme Director  
DNV  
2019-2021



Trine Boyer  
Engineer Research  
and Development  
Stavanger Research  
Centre,  
TotalEnergies E&P  
Norge  
2021-2022



Vanessa Richon  
R&D Asset Decarbon-  
ization Manager,  
Stavanger Research  
Centre,  
TotalEnergies EP  
Norge AS  
2022-2023

## CENTRE MANAGEMENT



Professor  
Sigurd Skogestad  
Centre Director  
2015-24



Professor  
Mary Ann Lundteigen  
Centre Co-Director  
2015-20  
2022-23

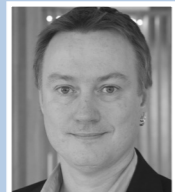

Professor  
Johannes Jäschke  
Deputy Director  
2021-23



Associate Professor  
Milan Stanko  
Deputy Director  
2021-23

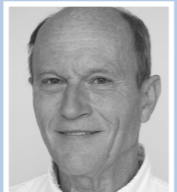

Jon Lippe  
Project Coordinator  
2015-19

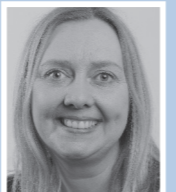

Gro Mogseth  
Technical Coordinator  
2015-20



Esma Benzaim,  
Project Coordinator  
2019-24

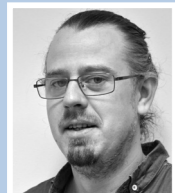

Pål J. Aune,  
Technical and  
Administrative  
Coordinator  
2020-24

## RESEARCH AREA MANAGERS/CORE TEAM



Professor Sigbjørn  
Sangesland,  
Field architecture  
2015-23



Professor Mary Ann  
Lundteigen  
Reliability, Availability,  
Maintenance and  
Safety (RAMS)  
2015-20



Professor Jørn Vatn,  
Reliability,  
Availability,  
Maintenance and  
Safety (RAMS)  
2020-23



Professor Johan  
Sjoblom  
Separation – Fluid  
characteristics  
2015-19



Professor Gisle Øye,  
Separation – Fluid  
characteristics  
2015-23



Professor Hanna  
Knuutila  
Separation – Process  
concepts  
2015-17



Professor Hugo Atle  
Jakobsen,  
Separation – Process  
concepts  
2017-23



Professor Sigurd  
Skogestad  
System control  
2015-20



Professor  
Johannes Jäschke,  
System control  
2020-23

## PROJECT MANAGERS/SUPERVISORS



Professor Anne  
Barros



Professor Kristofer  
Gunnar Paso



Professor Olav  
Egeland



Senior Principal  
Researcher Tore  
Myhrvold (DNV)

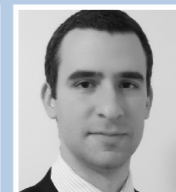

Associate Professor  
Milan Stanko



Professor Tor Berge  
Gjernvik



Professor Mary Ann  
Lundteigen

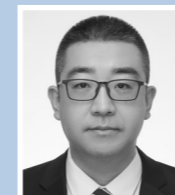

Professor Shen Yin  
(DNV)



Professor Magne  
Hillestad



Professor Hanna K.  
Knuutila



Professor Liyuan Deng



Associate Professor  
Brian Arthur Grimes

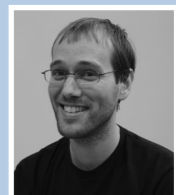

Associate Professor  
Christian Holden

## CO-SUPERVISORS



Postdoctoral fellow  
Jesus de Andrade



Professor Antoine  
Rauzy



Professor Emeritus  
Hallvard Fjøsne  
Svendsen



Postdoctoral fellow  
Jannike Solsvik



Researcher  
Esmaeil  
Jahanshahi



Professor Bjarne Foss



Professor Emeritus  
Michael Golan



Associate Professor  
Hyunglu Kim



Postdoctoral fellow  
Luca Ansaloni



Postdoctoral fellow  
Zhongde Dai



Adjunct Professor  
Audun Faanes,  
(Equinor)



Adjunct Professor  
Gunleiv Skofteland,  
(Equinor)



Doctor Eivind  
Johannessen,  
(Equinor)



Svein Viggo Aanesen,  
(Equinor)



Professor Markus  
Glaser (Aalan  
University)

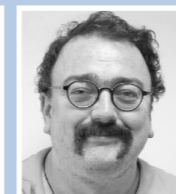

Dr. Sebastien Charles  
Simon



Dr. Marcin Dudek

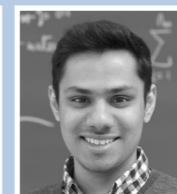

Associate  
Professor Dinesh  
Krishnamoorthy



Adjunct Professor  
Frank Ove Westrad



Adjunct Professor Geir  
Humborstad Sørland



Professor Yiliu Liu



Dr. Edmary  
Altamiranda,  
Aker BP



Associate Professor  
Idelfonso Nogueira



## PHD STUDENTS



Yuntao Zhang (2016-17) and (2018-19) | Are Bertheussen (2016-17) and (2018-19) | Gilberto Nunez (2017-18) and (2018-19) - (discontinued) | Yun Zhang (2017-18) and (2018-19) | Jost Ruwoldt (2017-18) and (2018-19) | Kristin Dalane (2017-18) and (2018-19) | Marcin Dudek (2018-19)



Tamal Das (2018-19) | Dinesh Krishnamoorthy (2016-17) and (2019-20) | Sveinung Johan Ohrem (2017-18) and (2019-20) | Eirini Skylogianni (2019-20) | Håvard Slettahjell Skjefstad (2019-20) | Torstein Thode Kristoffersen (2019-20) | Diana Gonzales (2016-17) and (2020-21)



Haoge Liu (2020-21) | Himanshu Srivastav (2020-21) | Mahdi Ahmadi (2020-21) | Timur Bikmukhametov (2020-21) | Adriaen Verhesyleweghen (2020-21) | Eirik Helno Herø (2016-17) and (2020-21) | Mishiga Vallabhan (2020-21) and (2021-22)



Leonardo Sales (2022-23) | Ilgar Azizov (2022-23) | Moein Assar (2022-23) | Md Rizwan (2022-23) - (discontinued) | Martina Piccioli (2020-21) and (2023-24) | Tae Hwan Lee (2020-21) and (2023-24) | Mehman Ahmadi (2023-24)

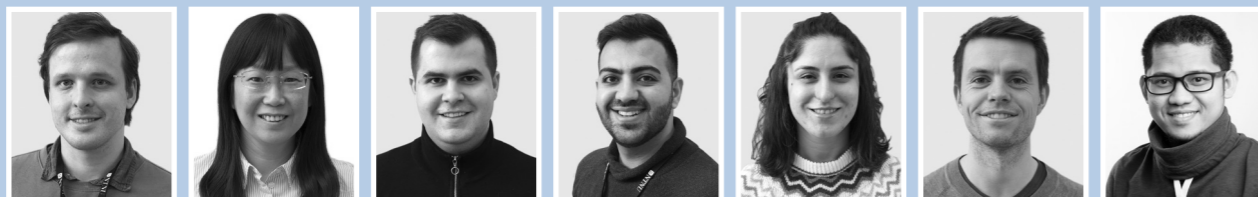

Ludvig Bjørklund (2023-24) | Jie Liu (2023-24) | George-Claudiu Savulescu (2023-24) | Hamidreza Asaadian (2023-24) | Asli Karacelik (2023-24) | Halvor Aarnes Krog (2023-24) | Risvan Dirza (2023-24)

()The years in parentheses refers to texts in SUBPRO's annual reports: interviews with the PhD students, final project reports/articles.

## POSTDOCTORAL FELLOWS



Jing shi (2016-17) | Aleksandar Yordanov Mehandzhiyski (2018-19) | Christoph Josef Backi (2018-19) | Hyungju Kim (2018-19) | Mariana Diaz (2020-21) | Hanieh Karbas Froushan (2020-21) | Marcin Dudek (2021-22)

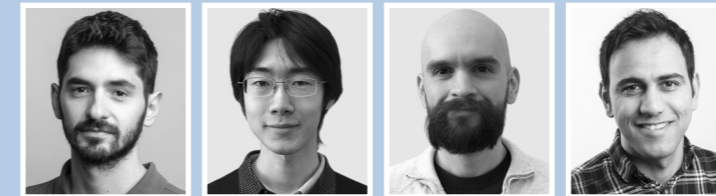

Jose Otavio Assumpcao Matias (2021-22) | Xingheng Liu (2022-23) | Lucas Cantinelli Sevellano (2022-23) | Mahdi Ahmadi (2022-23)

() The years in parentheses refers to texts in SUBPRO's annual reports: final project reports/articles of the Postdoctoral fellows.

## RESEARCHERS (RESEARCH PROJECTS)



Haoge Liu (2022-23) | Abraham A. Parra Suarez (2022-23) | Xingheng Liu (2022-23) | Husnain Ahmed (2022-23) | Suparna Paul (2022-23) | Niloufar Khesavarz Rezaei (2022-23) | Diego Di Domenico Pinto (2022-23)



Juliette Limpach (2022-23) | Nicolas La Forgia (2022-23) | Tamires de Souza da Silva (2023-24) | Carine de Menez Rebello (2023-24)

## ASSOCIATED PHD STUDENTS, RESEARCHERS AND POSTDOCTORAL FELLOWS



Nanda Anugrah Zikrullah (Associated project Sfety 4.0) (2021-22) | Postdoctoral fellow Dinesh Krishnamoorthy (Associated project AutoPRO) (2020-21) | PhD student Malik Mohsin Abbas (Spin-off project AutoPRO) (2020-21) | PhD student Sandeep Prakash (Spin-off project AutoPRO) (2021-22) | PhD student Emefon Dan (Spin-off project AutoPRO) (2022-23) | PhD student Evren Mert Turan (Spin-off project AutoPRO) (2023-24) | Postdoctoral fellow Rafael David de Oliveira (Spin-off project AutoPRO) (2023-24)



PhD Student M. Gibran Alfarazi (Associated project Prognostics and health mgmt. of safety systems) (2023-24)

() The years in parentheses refers to texts in SUBBPRO's annual reports: final project reports/articles of the associated students.



# SUBPRO

SUBSEA PRODUCTION AND PROCESSING

## CONTACT PERSONS

Professor Sigurd Skogestad, Centre Director  
sigurd.skogestad@ntnu.no  
+47 913 71 669

Professor Mary Ann Lundteigen, Centre Co-Director  
mary.a.lundteigen@ntnu.no  
+47 930 59 365

Professor Johannes Jäschke, Deputy Director  
johannes.jaschke@ntnu.no  
+47 984 12 239

Assoc. Professor Milan Stanko, Deputy Director  
milan.stanko@ntnu.no  
+47 954 40 756

Esma Benzaim, SUBPRO Project Coordinator  
esma.benzaim@ntnu.no  
+47 936 58 805

Pål J. Aune, SUBPRO Zero Coordinator  
pal.aune@ntnu.no  
+47 926 60 270

[www.ntnu.edu/subpro](http://www.ntnu.edu/subpro)



SUBPRO team at NTNU  
in front of Subsea Distribution Unit  
from the Njord field, Equinor

Printed May 2024  
Editors: Jon Lippe and Esma Benzaim  
Graphical design and printing: NTNU Graphic Centre  
Photos: Thor Nielsen and Per Henning

**sfi** = Centre for  
Research-based  
Innovation

Established by the Research Council of Norway

**NTNU**  
Norwegian University of  
Science and Technology