

Correction to “Systematic Design of Active Constraint Switching Using Classical Advanced Control Structures”

Adriana Reyes-Lúa and Sigurd Skogestad*

Ind. Eng. Chem. Res. 2020, 59 (6), 2229–2241, DOI: 10.1021/acs.iecr.9b04511

 Cite This: *Ind. Eng. Chem. Res.* 2020, 59, 9342–9342

 Read Online

ACCESS |

 Metrics & More

 Article Recommendations

Page 2240. In the published version of this paper, with regard to Figure 21, there is a missing dashed line going from the SRC block (signal 3) to the *min* selector block that gives the set point to the inlet flow controller (FC). The correct figure should appear as follows:

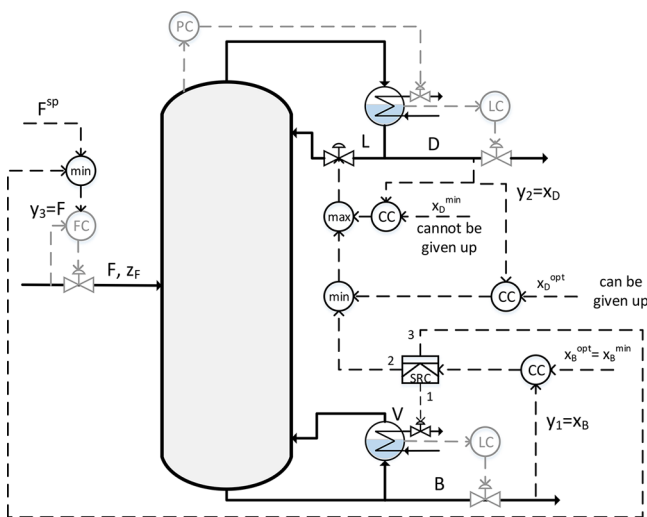

Figure 21. Alternative control structure for distillation column (all regions). This structure behaves differently from that in Figure 18 when maximizing throughput (region IV).

Published: April 28, 2020

