

20<sup>th</sup> European Symposium on Computer Aided Process Engineering – ESCAPE20  
S. Pierucci and G. Buzzi Ferraris (Editors)  
© 2010 Elsevier B.V. All rights reserved.

## Plantwide Control for Economic Operation of a Recycle Process

Rahul Jagtap<sup>a</sup>, Nitin Kaistha<sup>b</sup> and Sigurd Skogestad<sup>c</sup>

<sup>a</sup> Chemical Engineering, IIT Kanpur 208016, India, Email: jagtap@iitk.ac.in

<sup>b</sup> Chemical Engineering, IIT Kanpur 208016, India, Email: nkaistha@iitk.ac.in

<sup>c</sup> Chemical Engineering, NTNU, Trondheim 7491, Norway, Email: skoge@ntnu.no

### Abstract

Plant-wide control system design for economically optimum operation of a recycle process with side reaction is studied. The process consists of a liquid phase CSTR followed by two simple distillation columns. The exothermic irreversible reactions  $A + B \rightarrow C$  (main reaction) and  $C + B \rightarrow D$  (side reaction) occur in the CSTR. The reactor effluent is distilled in the recycle column to recycle the light reactants (A and B) back to the CSTR. The column bottoms is further distilled in the product column to produce nearly pure C as the overhead product with side-product D leaving from the bottoms. For a base-case design, the steady-state operating degrees of freedom are optimized to maximize operating profit for two modes of operation – Mode I: Given fresh A feed rate and Mode II: Maximum through-put. The set of active constraints at the economic optimum significantly simplifies the plant-wide control design problem by forcing structural decisions for process operation close to and where possible, at the active constraints. The economic performance of the control structure so synthesized is compared with other reasonable regulatory structures with and without a supervisory optimizing constraint controller. Quantitative process operation back-off results show that the incorporation of economic considerations in plantwide control system design can significantly improve profitability.

**Keywords:** Plantwide control, control system design, economic operation

### 1. Introduction

The plantwide control system for chemical processes typically consists of a regulatory layer that ensures safe and stable operation and an economic optimization layer that adjusts key setpoints in the regulatory layer for optimizing an economic criterion such as operating profit or energy consumption. The design of the regulatory plantwide control system has been extensively studied in the literature. The combinatorial complexity of the plantwide control structure design problem results in several reasonable structures that provide safe and stable process operation.

To systematize the choice of the loop pairings in the regulatory layer, Luyben et. al. proposed a nine-step bottom-up heuristic design procedure for “smooth” process operation [1]. An inherent disadvantage of this bottom-up approach is that economic considerations are inadvertently ignored. Given that the optimum economic operating point typically lies at the intersection of process constraints, the implemented regulatory control system affects the transients in these “active” constraint variables and hence a “back-off” is necessary to avoid transient hard constraint violation. Structures minimizing the transients in the active constraints would require smaller back-offs with consequently better economic performance

while ensuring safe and stable operation. Skogestad [2] termed such regulatory structures with an acceptable economic loss as self-optimizing. Based on the concept, a systematic design procedure that uses *a priori* knowledge of active constraints at the economic optimum to synthesize the regulatory control system has been proposed [3,4].

Notwithstanding the simplicity of self-optimizing structures, what constitutes “acceptable” economic loss is quite subjective. In particular, even a small relative increase in production (say 1%) can translate into millions of dollars of additional revenue for the volume driven process industry. Quantification of the benefit of a supervisory economic optimizing controller on top of the regulatory layer is thus highly desirable. Further, even as self-optimizing control of complex chemical processes has been demonstrated in the literature, studies that quantify the back-off due to dynamic transients with or without a supervisory controller are lacking. This work is intended to fill this void through a case-study on a recycle process with side reaction.

In the following, a brief process description is provided followed by optimized operating conditions for two modes of operation corresponding to a given fresh feed processing rate (Mode I) and throughput maximization (Mode II). The active constraints at the optimum for each Mode are used to synthesize regulatory control structures using the systematic procedure of Skogestad. The economic performance of the synthesized control structures is quantitatively compared with other reasonable regulatory structures with and without an explicit supervisory optimizing controller. The article ends with the conclusions.

## 2. Process Description, Design and Optimum Operation

The process consists of a liquid phase CSTR followed by two distillation columns. The exothermic reactions  $A + B \rightarrow C$  (main reaction) and  $C + B \rightarrow D$  (side reaction) occur in the CSTR. The reactor effluent is distilled in the recycle column to recycle the light reactants (A and B) back to the CSTR. The column bottoms is further distilled in the product column to produce nearly pure C as the overhead product with side-product D leaving from the bottoms. The reaction chemistry necessitates reactor operation in excess A environment to suppress the side reaction. Figure 1 shows a schematic of the process along with salient design and base-case operating parameters for processing 100 kmol/h of fresh A to produce 99 mol% pure C. Table 1 reports the reaction kinetics and hypothetical component properties for modeling in Hysys.

There are a total of eight steady state operational degrees of freedom for this process; two for the feeds (two feed rates), two for the reactor (temperature and holdup) and two each for the two columns. We choose the following variables as steady-state degrees of freedom (any independent set may be chosen): The fresh A feed rate, the reactor feed A to B excess ratio, the reactor level and temperature, the recycle column distillate C mol fraction (or reflux

Table 1: Modeling details of recycle process

Kinetics	A+B $\rightarrow$ C	$r_1 = k_1 x_A x_B$	$k_1 = 2 \times 10^8 \exp(-60000/RT)$	
	B+C $\rightarrow$ D	$r_2 = k_2 x_B x_C$	$k_2 = 1 \times 10^9 \exp(-80000/RT)$	
Hypotheticals	MW	NBP ( $^{\circ}$ C)	Hydrocarbon estimation procedure used to estimate parameters for thermodynamic property calculations	
	A	50		80
	B	80		100
	C	130		130
D	210	180		
VLE	Soave-Redlich-Kwong			

Reaction rate units:  $\text{kmol.m}^{-3}.\text{s}^{-1}$

*Plantwide Control for Economic Operation of a Recycle Process*

rate) and bottoms B to C mol ratio and the product column distillate C mol fraction and bottoms C component flow rate.

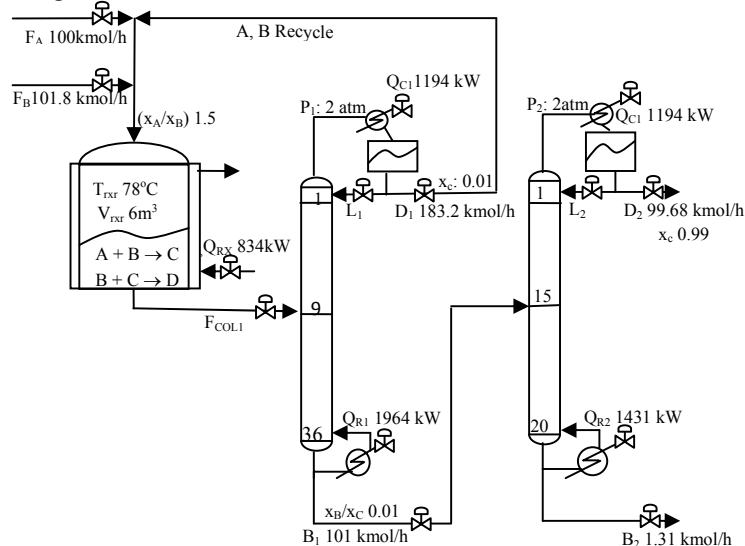

Figure 1: Schematic of Simple Recycle Process

Table 2: Optimization Summary

Objective	Max. (Product price – raw material price – energy costs)	
	60 °C < $T_{rxr}$ < 100 °C	
Constraints	0 < Material flows < 2(base-case)	
	0 < Energy flows < 2(base-case)	
	0 < Column boilups < 1.5(base-case)	
	0 < $R_{rxr}$ Holdup < 6 m <sup>3</sup>	
<i>Optimized Operating Conditions</i>		
<i>Variable</i>	<i>Mode I</i>	<i>Mode II</i>
$F_A$	100 kmol/h	184.6 kmol/h
$V_{rxr}$	6 m <sup>3</sup> (max)	6 m <sup>3</sup> (max)
$T_{rxr}$	70.47 °C	100 °C (max)
$(x_A/x_B)^{R_{rxr}Feed}$	2.3270	1.6698
$L_1$	~0 kmol/h	~0 kmol/h
$(x_B/x_C)_{Col1}^{Bottoms}$	0.01	0.01
$(x_C)_{Col2}^{Distillate}$	0.99	0.99
$(b_C)_{Col2}$	0.5 kmol/h	0.5 kmol/h
Profit per yr	\$2.793x10 <sup>6</sup>	\$4.615x10 <sup>6</sup>
Active Constraints	Col 1 Maximum Boilup Maximum reactor holdup	

Optimally, the values of the eight steady state operating degrees of freedom should be chosen to optimize an economic criterion such as maximizing plant operating profit (product price – raw material price – energy costs) subject to operating constraints (maximum/minimum flows, pressures and temperatures). Optimization for two modes of operation is studied. In Mode I, the fresh A feed to be processed is specified (e.g. dictated by product demand). In Mode II, the fresh A feed to be processed is also an optimization variable for maximizing operating profit. This mode typically corresponds to maximizing the process through-put for the highest possible production rate of the value-added product.

The optimization problem and results for Mode I and Mode II operation are summarized in Table 2. In both modes of operation, the recycle column maximum boil-up constraint and the maximum reactor level constraint are

active. In Mode I, the fresh A feed rate is fixed while in Mode II, the maximum reactor temperature constraint is active. Also, the recycle column reflux rate is small at the optimum for both modes. This corresponds to the recycle column essentially operating as a stripper (no enriching). Setting the reflux rate to zero and reoptimizing gives a maximum profit very close to the actual optimum (difference in hundreds of dollars). Accordingly, column operation at zero reflux ie as a stripper is considered optimal. The remaining three specifications for both modes correspond to the recycle column bottoms B to C mol ratio of 1%, a product purity of 99% and holding the C loss in the byproduct stream at a small value (0.5 kmol/h in the study). In both modes of operation, all the operating degrees of freedom are thus exhausted.

The optimization results may be interpreted as follows. For Mode I operation, the active maximum reactor volume constraint allows for a lower operating temperature with increased yield to the desired product C. The active maximum boil-up constraint for the recycle column corresponds to increasing the recycle of A so that the reactor excess A is as large as possible for higher product yield. For Model II operation (maximum through-put), operating the reactor at maximum level and temperature maximizes the conversion and hence the production rate. Operating the column at maximum boil-up causes higher amounts of fresh A to be processed without compromising selectivity (maximum allowable recycle).

### 3. Plantwide Control Structures

The active constraints for the different modes of operation dictate control structure decisions. In both operating modes, the recycle column vapor boil-up constraint is active and the column should be operated as a stripper. Accordingly, the reflux rate is fixed at zero and the reboiler duty is set for maximum permissible boil-up. A tray temperature in the stripping section is maintained by adjusting the column feed for maintaining B impurity in the bottoms. The reactor level is maintained by adjusting the  $F_B$  with  $F_A$  being maintained in ratio. The ratio set-point is adjusted to maintain the A/B composition ratio of the reactor feed. In Mode I operation, since the desired fresh A to be processed is specified, a discrepancy from this specification is used to

adjust the A/B composition ratio set-point. Alternatively, the reactor temperature set-point may be adjusted. We found the former to entail slightly lower steady state economic loss due to disturbances. In Mode II operation, the A/B composition ratio set-point is kept fixed. In both modes, the plantwide control structure is the same except for the adjustment in A/B

Table 3: Plantwide control structures evaluated

Control Task	Adjusted Variable			
	CS1	CS2	CS3	CS4
<i>Regulatory Control System</i>				
TPM*	$Q_{R1}$	$F_{COL1}$	$F_{CSTR}$	$F_A$
Fresh Feed Ratio#	$F_A/F_B$	$F_A/F_B$	$F_A/F_B$	$F_B/F_A$
$x_{A(rxfeed)}$	$(F_A/F_B)^{SP}$	$(F_A/F_B)^{SP}$	$(F_A/F_B)^{SP}$	$(F_B/F_A)^{SP}$
$T_{RX}$	$Q_{RX}$	$Q_{RX}$	$Q_{RX}$	$Q_{RX}$
Reactor level	$F_B$	$F_B$	$F_{COL1}$	$F_{COL1}$
Col 1 $T_{12}$	$F_{COL}$	$Q_{R1}$	$Q_{R1}$	$Q_{R1}$
Col 1 Top Level	$D_1$	$D_1$	$D_1$	$D_1$
Col 1 Sump Level	$B_1$	$B_1$	$B_1$	$B_1$
Col 2 Top Level	$D_2$	$D_2$	$D_2$	$D_2$
Col 2 Sump Level	$Q_{R2}$	$Q_{R2}$	$Q_{R2}$	$Q_{R2}$
Col 2 ( $B_2 * x_c$ )	$B_2$	$B_2$	$B_2$	$B_2$
<i>Supervisory Control Loops</i>				
$F_A$ (Mode I)	$x_{A(rxfeed)}^{SP}$	$x_{A(rxfeed)}^{SP}$	$x_{A(rxfeed)}^{SP}$	TPM
Boilup (Mode I)	TPM	TPM	TPM	$x_{A(rxfeed)}^{SP}$
Boilup (Mode II)	TPM	TPM	TPM	TPM

\*: Throughput manipulator

#: Stream in denominator is the wild stream

*Plantwide Control for Economic Operation of a Recycle Process*

excess ratio set-point for Mode I. The remainder of the control structure is standard and is referred to as CS1 (see Table 3 for loop pairings).

CS1 utilizes *a priori* knowledge of the active constraints to locate the throughput manipulator at the principal bottleneck, the recycle column boilup. The remainder of the inventory control system is then “radiating” around it (Price and Georgakis [5]). For comparison, we also consider other reasonable regulatory control structures with alternative throughput manipulator locations. These structures (CS2-CS4) are summarized in Table 3. The feed to the column, total feed to the reactor and the fresh A feed are respectively the throughput manipulators in CS2, CS3 and CS4. For mode I operation, an excess ratio controller similar to CS1 is required for CS2 and CS3 but not CS4 since the latter directly fixes the fresh A feed. For CS2-CS4, a supervisory optimizing controller that adjusts the throughput manipulator to control the boilup near maximum can also be implemented for tighter boilup control to reduce the back-off in the boilup due to disturbances in both operating modes.

#### **4. Results and Discussion**

Of the active constraints, the maximum level and maximum boil up constraints are considered as hard. Rigorous dynamic simulations are performed to quantify the back-off necessary to avoid violating these constraints during transients due to disturbances. A 5% step increase in the heavy impurity in the fresh B feed stream is considered as the worst case disturbance. To quantify the impact of the supervisory boilup optimizing controller, the back-off is performed for operation at constant throughput manipulator setpoint (optimizing controller is off) and with the optimizing controller on.

The back-off in the level for both modes and CSTR temperature for mode II is about the same in all structures. The boilup back-off however varies significantly. Table 4 reports the salient operating parameters at the final steady state for derated process operation with and without the boilup optimizing controller. Notice that the boilup back-off increases in order  $CS1 < CS2 < CS3 < CS4$ . Also note that in both modes, an optimizing boilup controller reduces the back-off. In mode I, as the back-off necessary in the boilup increases, the A/B reactor feed excess ratio must decrease to process the same amount of A feed. In mode II operation, back-off in the boilup is directly related to the amount of fresh feed processed and hence the product rate. The lower the back-off, the higher the amount of feed processed with consequently better economic performance.

The plant operating profit results show that while the operating profit is relatively insensitive to back-off in mode I operation (because the profit curve is very flat near the optimum), the implemented control structure can significantly affect profitability in mode II. For example, the difference in profit between CS1 and CS4 with and without a boilup optimizing controller is respectively about \$200,000 and \$350,000, a relative change of more than 4% and 7.5%, respectively. Also, the application of an optimizing controller improves operating profit by more than 1% in all the structures where a boilup optimizing controller can be implemented (CS2-CS4). Notice that as the throughput manipulator location moves away from the bottleneck, the relative increase in profit using an optimizing controller improves over process operation at a constant derated throughput manipulator setpoint. In cases where the regulatory control system is already implemented and the

throughput manipulator location is away from the principal bottleneck, there exists significant incentive for implementing a supervisory controller for improving plant profitability. However, when possible, the plantwide regulatory control system should be designed so that the throughput manipulator is at (or close) to the principal bottleneck.

Table 4: Salient parameters for derated process operation for CS1-CS4(dynamics)

	$F_A$ kmol/hr		$F_C$ kmol/hr		$(X_A/X_B)_{\text{rxr feed}}$		Col 1 Boilup kmol/hr		Profit $\times 10^6$ \$/year	
	a	b	a	b	a	b	a	b	a	b
<i>Mode I Operation</i>										
Base	100		97.57		2.327		321.1		2.793	
CS1	100	100	98.06	98.06	2.318	2.318	321.1	321.1	2.793	2.793
CS2	100	100	98.11	98.07	2.234	2.289	311.2	317.7	2.803	2.813
CS3	100	100	98.17	98.13	2.154	2.22	301.5	309.2	2.815	2.81
CS4	100	100	98.21	98.21	2.143	2.143	299.3	299.3	2.817	2.817
<i>Mode II Operation</i>										
Base	184.6		180.62		1.635		321.1		4.615	
CS1	179.1	179.1	176.7	176.7	1.627	1.627	321.1	321.1	4.595	4.595
CS2	174	175.7	171.6	173.4	1.629	1.627	309.4	313.6	4.444	4.502
CS3	170.3	174.1	168	171.8	1.627	1.628	299.2	308	4.314	4.424
CS4	167.8	173.4	165.5	171.1	1.627	1.628	294.2	307	4.248	4.416

a: Without boilup optimizing controller.

b: With boilup optimizing controller

## 5. Conclusions

In conclusion, this case study demonstrates that the regulatory plantwide control system can significantly affect process profitability. *A priori* knowledge of the active constraints at the economic optimum operating point should be used to synthesize a control structure that mitigates the transient variability in the principal hard bottleneck constraint for reduced back-off from the optimum and hence better economic performance. Quantitative results show that locating the throughput manipulator at the principal bottleneck constraint mitigates the back-off.

## Acknowledgments

Support from Erasmus EU-India exchange program is gratefully acknowledged.

## References

1. M.L. Luyben, B.D. Tyreus and W.L. Luyben, 1997, Plant-wide Control Design Procedure, AIChE J. 43, 3161-3174.
2. S. Skogestad, 2000, Plantwide Control: The Search for the Self Optimizing Control Structure, J. Proc. Cont. 10(5), 487-507.
3. T. Larsson and S. Skogestad, 2000, Plantwide control- A review and a new design procedure, Mod. Ident. Cont. 21, 209-240.
4. S. Skogestad, 2004, Control Structure Design for Complete Chemical Plants, Comp. Chem. Eng. 28, 219-234.
5. R.M. Price and C. Georgakis, 1993, Plantwide regulatory control design procedure using a tiered framework, Ind. Eng. Chem. Res. 32, 2693-2705.