

## Dynamic degrees of freedom for tighter bottleneck control

Elvira Marie B. Aske<sup>a,b</sup>, Sigurd Skogestad<sup>a</sup>

<sup>a</sup>*Department of Chemical Engineering, Norwegian University of Science and Technology, 7491 Trondheim, Norway.*

<sup>b</sup>*StatoilHydro, Research & Development, 7005 Trondheim, Norway.*

### Abstract

To realize maximum throughput, tight control of the bottleneck unit(s) is necessary. Dynamic degrees of freedom can be used to obtain tighter bottleneck control. Here, “dynamic” means that the degree of freedom has no steady-state effect on plant operation, like most inventories (levels). Nevertheless, temporary changes of inventories can allow for dynamic changes in the flow through the bottleneck that keeps the process closer to its bottleneck constraint and increase the throughput.

**Keywords:** Throughput maximization, bottleneck, inventory, ratio control

### 1. Introduction

In many cases, prices and market conditions are such that optimal operation is the same as maximizing plant throughput. In this case, the optimum lies at constraints, and in order to maximize throughput, the flow through the bottleneck(s) should be at its maximum at all times (Aske *et al.*, 2008). If the actual flow through the bottleneck is not at its maximum at any given time, then this gives a loss in production that can never be recovered. Tight bottleneck control is therefore important for maximizing throughput and avoiding losses.

In existing plants, the most common approach for controlling the throughput is to set the feed flow at the inlet of the plant and use inventory control in the direction of flow (Price *et al.*, 1994). One reason for this is that most of the control structure decisions are done at the design stage (before the plant is built), where one usually assumes a fixed feed rate. However, tight bottleneck control requires that the throughput manipulator (TPM) is located close to the bottleneck (Skogestad, 2004). The term “close to the bottleneck” means that there is a short effective delay from the input (TPM) to the output (bottleneck flow).

Ideally the TPM should be located at the bottleneck, but this may not be desirable (or even possible) for other reasons. First, if the TPM is moved, the inventory loops must be reconfigured to ensure self-consistency (Aske and Skogestad, 2009). Second, there may be dynamical reasons for avoiding a so-called on-demand control structure with inventory control opposite the direction of flow (Luyben, 1999). Third, if a bottleneck(s) moves in the plant due to disturbances, then single-loop control requires relocation of TPM and reconfiguration of inventory loops. Thus, in practice one is often left with a fixed throughput manipulator, usually the feed rate. This usually leads to a large effective delay (“long loop”) because the bottleneck is usually located inside the plant, and this leads to an economic loss because of a large required back off from the bottleneck constraints.

There are also related issues in business systems for using inventories as degree of freedom. Supply chains are sometimes modelled as continuous processes and

Schwartz *et al.* (2006) used simulation to study decision policies for inventory management.

## 2. Alternative strategies for bottleneck control

Assume that the objective is to maximize the flow through the bottleneck and that the feed rate is available as a degree of freedom (TPM). Figure 1 shows four ways of achieving this using simple single-loop control structures.

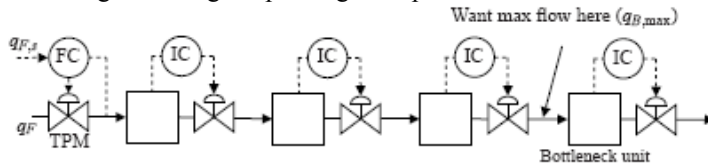

(a) **Traditional configuration** (manual control of feed rate). The feed rate is the degree of freedom for manipulating throughput (TPM), and inventory control is in the direction of flow. To maximize the flow through the bottleneck, the operators change the feed valve manually based on information about the plant operation and experience.

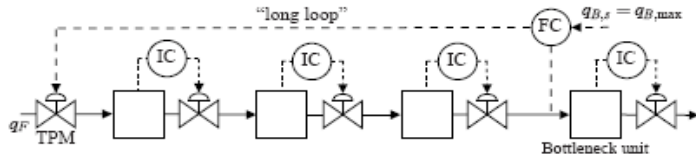

(b) **Alternative 1: Single-loop control of bottleneck flow using the feed rate.** *Problem:* The “long loop” gives a large effective delay from the feed flow (input) to the bottleneck flow (output), so tight control of the bottleneck flow is difficult.

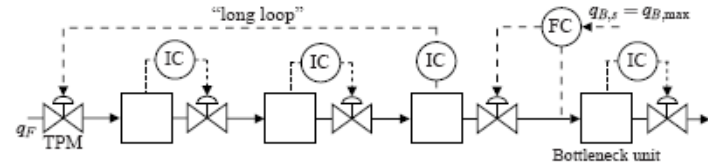

(c) **Alternative 2: Move TPM from feed to bottleneck.** This achieves tight control of the bottleneck flow. The inventory loops are not reconfigured, so the feed rate now needs to take over the “lost task” which in this case is control of the inventory upstream of the bottleneck. *Problem:* The “long loop” gives a large effective delay so control of the “lost task” may be poor.

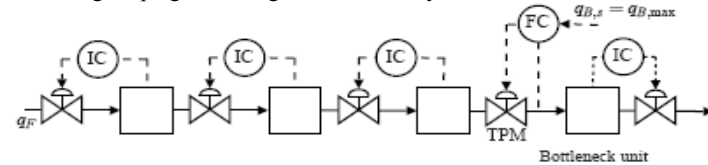

(d) **Alternative 3: Reconfigure inventory control.** The TPM is moved to the bottleneck and at the same time all the upstream inventory loops are reconfigured to be in the opposite direction of flow. Tight bottleneck control (of both flow and local inventory) may be achieved. *Problem:* Reconfiguration of inventory loops is usually very undesirable from a practical point of view.

Figure 1: Simple single-loop control structures for maximizing bottleneck flow in serial process. IC stands for inventory controller (e.g. level controller).

In summary, none of the alternatives in Figure 1 are desirable. To improve control and keep the flow through the bottleneck closer to its maximum at all times, we would like to have additional degrees of freedom, and the only ones that are normally available are the inventories (holdups) in the buffer tanks, which can be used to make

dynamic flow changes. The word "dynamic" is used because most inventories have no steady-state effect on plant operation.

The main idea is as follows: To change the flow through the bottleneck, for example, to increase it, we temporarily reduce the inventory in the upstream holdup volume. However, this inventory needs to be kept within bounds, so if we want to increase the bottleneck flow permanently, we need to increase the flow into this part of the process and so on, all the way back to the feed (throughput manipulator). The simplest (but not generally optimal) approach is to use a "ratio" control system where all flows upstream the bottleneck are increased simultaneously by the same relative amount. The idea is illustrated in Figure 2.

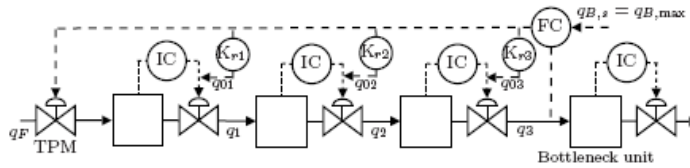

(a) **Alternative 1D: Single-loop plus ratio control.** The idea is to control the bottleneck flow by simultaneously changing all the flows upstream of the bottleneck by the same relative amount. The advantage is that the effective delay from the feed to the bottleneck may be significantly reduced and even eliminated in some cases. However, the dynamic flow changes are counteracted by the inventory controllers. In particular, note that the feed flow is the only degree of freedom that has a steady-state effect on the bottleneck flow. The strategy may also be viewed as a "ratio feedforward controller" from the feed flow to the downstream flows.

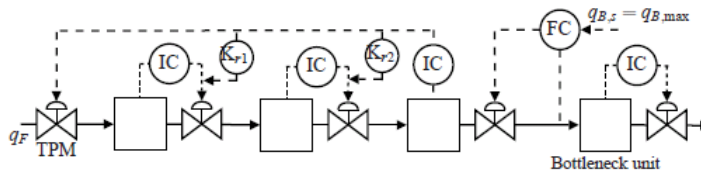

(b) **Alternative 2D: Move TPM to bottleneck and add ratio control to "lost task".** The TPM is moved to the bottleneck and the "lost task" (inventory upstream the bottleneck) is controlled by the feed rate. The use of ratio control is the same as for Alternative 1D. The effective delay from the feed rate to the lost task is reduced by using ratio control.

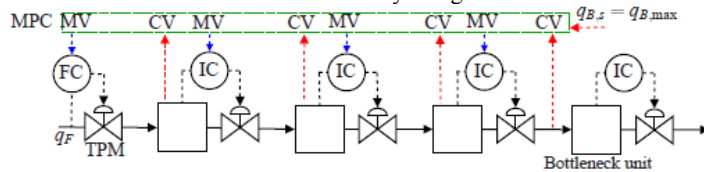

(c) **Alternative 4: Multivariable controller.** A multivariable controller (e.g. MPC) uses the feed rate and the inventory controller set points as manipulated variables (MVs). The controlled variables (CVs) are the bottleneck flow and inventory constraints.

Figure 2: Structures for controlling bottleneck flows that use inventories as dynamic degrees of freedom (with no reconfiguration of the inventory loops). Alternative 1D is studied in this paper. IC stands for inventory controller (e.g. level controller) and  $K_{r_i}$  is a constant gain (ratio controller).

The most obvious is to adjust the inventory set point  $I_s$ , but it is more direct in terms of flow changes to adjust the bias  $q_0$ . The two approaches are not very different, because a change in  $q_0$  can equivalently be implemented as a set point change by choosing  $I_s = -q_0/K(s)$ , where  $K(s)$  is the feedback controller. In this paper, we choose to use the bias  $q_0$  as the dynamic degree of freedom for ratio control. The important point to note is that there are no dynamics in  $K_r$ . This means that all the flows  $q$  are changed simultaneously when  $q_F$  changes.

### 3. Example: Four distillation columns in series

Consider four distillation columns in series, as shown in Figure 3. The four columns represent the liquid upgrading part of a gas processing plant and consist of a deethanizer, a depropanizer, a debutanizer and a butane splitter. Assume that the butane splitter is the bottleneck unit. The throughput is manipulated at the feed to the first column. The idea is to use the column inventories (sump or condenser drum holdup) as dynamic degrees of freedom to obtain tighter bottleneck control.

The distillation column models are implemented in Matlab/Simulink. Each of the four columns is modelled as multicomponent distillation with one feed and two products, constant relative volatilities, no vapor hold-up, constant molar flows, total condenser and liquid flow dynamics represented by the Francis weir formula. All columns use the “LV-configuration” where distillate ( $D$ ) and bottoms flow ( $B$ ) are used for inventory control ( $M_D$  and  $M_B$ ). To stabilize the column composition profile, all columns have temperature control in the bottom section by manipulating the boilup. The column inventories  $M_D$  and  $M_B$  are controlled with P-controllers with gain  $K_c = I/\tau_V$ . Here we use “smooth” level control where we set  $\tau_V = V_{\text{tank}}/q_{\text{out}}$  (Skogestad, 2006) where  $q_{\text{out}}$  is the flow out of the volume ( $D$  or  $B$ ). The temperature controllers (TC) are tuned with SIMC PI-tuning (Skogestad, 2003) with  $\tau_c = 0.5$  min.

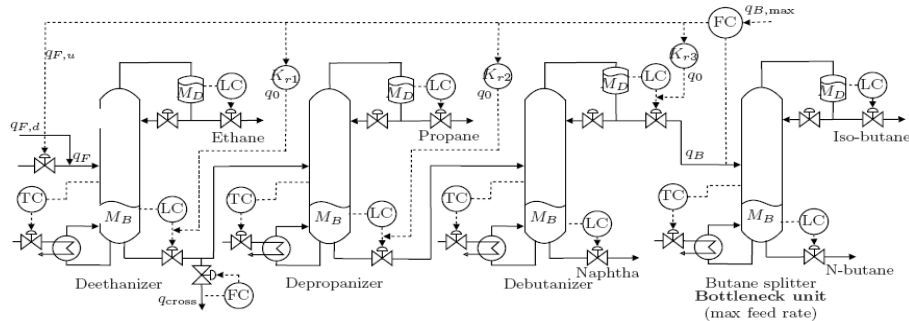

Figure 3: Distillation process: Four columns in series, here shown with throughput controlled by using single-loop with ratio control (Alternative 1D).

Two disturbances are considered. First, at  $t = 10$  min, we make a 5% increase in the bottleneck flow set point ( $q_{B,s}$ ). Second, at  $t = 210$  min, there is an 8% unmeasured decrease in the feed rate to the deethanizer ( $q_F$ ). The net feed flow is  $q_F = q_{F,u} + q_{F,d}$ , where  $q_{F,u}$  is the flow contribution from the controller (initially  $q_{F,d} = 0$  and  $q_F = q_{F,u} = 100$ , but then  $q_{F,d} = -8$  at  $t = 210$ ).

Four different control structures are tested for maximizing throughput:

1. **Manual:** Traditional (manual) control of the throughput. We assume that a skilled operator can immediately change the feed rate to the value corresponding to the new bottleneck flow set point. However, we assume that the operator does not notice the

unmeasured feed flow disturbance, so no adjustment is therefore done for the feed rate disturbance.

2. **Single-loop:** Single-loop control where the bottleneck flow is controlled using the feed rate (Alternative 1). We want smooth tuning to avoid overshoot and “aggressive” use of the feed valve. Therefore, the bottleneck flow controller (FC) is tuned with SIMC tunings with  $\tau_c = 3\theta$  for smooth tuning (Skogestad, 2006).
3. **Single-loop with ratio:** Use of the inventories as dynamic degrees of freedom by adding a bias ( $q_0$ ) to the inventory controller outputs as in Figure 3 (Alternative 1D). In this case there is no effective delay and the bottleneck flow controller (FC) is tightly tuned with a short integral time, which are typical FC tuning parameters.
4. **Multivariable:** MPC with the feed rate and the inventory set points as MVs and the bottleneck flow and level constraints as CVs (Alternative 4). The built-in MPC toolbox in Matlab is used and tuned with a low penalty on the use of inventories (MV moves) and a high penalty on the deviation from the bottleneck flow set point (CV set point).

The four control structures are evaluated in terms of how tightly the bottleneck flow ( $q_B$ ) is controlled in spite of disturbances. The resulting bottleneck flow ( $q_B$ ), the net feed flow ( $q_F$ ) and the inventories used as dynamic degrees of freedom (deethanizer  $M_B$ , depropanizer  $M_B$  and debutanizer  $M_D$ ) for the four different control structures are displayed in Figure 4. The bottleneck control is significantly tighter with ratio control and MPC where inventories are used as dynamic degrees of freedom. The inventories are quite tightly controlled with surprisingly small variations. This follows because the disturbances introduced here are small compared to what the IC’s are tuned to handle.

(a) Response in bottleneck flow  $q_B$  (CV)(b) Responses in feed flow  $q_F$  (MV)(c) Responses in deethanizer bottoms level  $M_B$  (d) Responses in depropanizer bottoms level  $M_B$ (e) Responses in debutanizer distillate level  $M_D$ 

Figure 4: Bottleneck control of the distillation process for four different control structures. 1) Manual control (dotted), 2) Single-loop control (dash-dotted), 3) Single-loop with ratio (solid), 4) MPC using both feed rate and inventories as MVs (dashed).

#### 4. Summary: Implications for design of inventory tanks

The effect of using inventories as dynamic degrees of freedom on the design of inventory tanks is summarized. The derivations are given in details in Aske (2009).

##### 4.1. Tank size

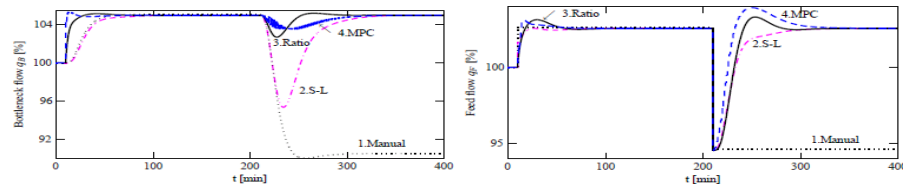
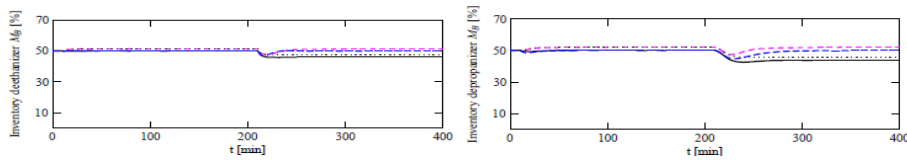
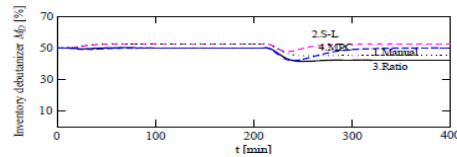
A desired change in tank throughput  $\Delta q_B$  results in a volume variation  $\Delta V$  and we have

$$|\Delta V| = \tau_G \cdot |\Delta q_B| \quad (1)$$

where  $\tau_G$  is the time constant for "refilling" the tank. In practice,  $\tau_G$  is the time for the flow rate into  $V$  to reach 63% of its steady-state change following a step in flow rate out of the (closest) upstream inventory. This is for the normal case when the TPM is upstream the bottleneck; the same formula applies also when it is downstream. For design purposes, the flow change  $|\Delta q_B|$  is the (steady-state) flow change through tank resulting from the largest expected throughput (bottleneck flow) change.

Equation (1) is useful for sizing the tank (inventory volume). In words, the expected volume variation for an inventory used for bottleneck control is approximately the expected variation in flow through the unit multiplied by the time constant for the flow dynamics for "refilling"  $V$  from the upstream inventory.

##### 4.2. Level control tuning

The level control tuning involves the closed-loop time constant ( $\tau_V$ ) for the level control loop in the inventory tank. We get

$$|\Delta V| = \tau_V \cdot |\Delta q_d| \quad (2)$$

where  $\Delta q_d$  is the flow rate change through the tank in question. Equation (2) can be used to tune the level controller, and then gives the well-known formula for smooth (averaging) level control. To see this, note that for a nominally half-full tank we must require  $|\Delta V_{peak}| < 0.5 V_{tank}$  to avoid overflowing or emptying. If we furthermore assume that the maximum expected change in flow through the tank is 50% of the nominal flow, then  $q_d = 0.5 q$ . This gives  $\tau_V < V_{tank}/q$ , which is the well-known value for smooth level control, (e.g. Skogestad (2006)).

#### References

- Aske, E., 2009, Design of plantwide control systems with focus on maximum throughput. Ph.D. thesis, Norwegian University of Science and Technology, Trondheim, Norway, available at [www.ntnu.no/users/skoge/publications/thesis/2009\\_aske/](http://www.ntnu.no/users/skoge/publications/thesis/2009_aske/).
- Aske, E., Skogestad, S., 2009. Self-consistent inventory control. Ind. Eng. Chem. Res. Submitted.
- Aske, E., Strand, S., Skogestad, S., 2008. Coordinator MPC for maximizing plant throughput. Comput. Chem. Eng. 32 (1-2), 195–204.
- Luyben, W., 1999. Inherent dynamic problems with on-demand control structures. Ind. Eng. Chem. Res. 38 (6), 2315–2329.
- Price, R. M., Lyman, P. R., Georgakis, C., 1994. Throughput manipulation in plantwide control structures. Ind. Eng. Chem. Res. 33, 1197–1207.
- Schwartz, J., Wang, W., Rivera, D., 2006. Simulation-based optimization of process control policies for inventory management in supply chains. Automatica 42, 1311–1320.
- Skogestad, S., 2003. Simple analytic rules for model reduction and PID controller tuning. J. Proc. Control 13, 291–309.
- Skogestad, S., 2004. Control structure design for complete chemical plants. Comput. Chem. Eng. 28, 219–234.
- Skogestad, S., 2006. Tuning for smooth pid control with acceptable disturbance rejection. Ind. Eng. Chem. Res. 45, 7817–7822.
- Skogestad, S., 2007. The dos and don'ts of distillation column control. Trans. IChemE, Part A 85 (A1), 13–23.