

# On the Trade-off between Energy Consumption and Food Quality Loss in Supermarket Refrigeration Systems

J. Cai and J. B. Jensen and S. Skogestad and J. Stoustrup

**Abstract**—This paper studies the trade-off between energy consumption and food quality loss, at varying ambient conditions, in supermarket refrigeration systems. Compared with the traditional operation with pressure control, a large potential for energy savings without extra loss of food quality is demonstrated. We also show that by utilizing the relatively slow dynamics of the food temperature, compared with the air temperature, we are able to further lower both the energy consumption and the peak value of power requirement. The Pareto optimal curve is found by off-line optimization.

## I. INTRODUCTION

Increasing energy costs and consumer awareness on food products safety and quality aspects impose a big challenge to food industries, and especially to supermarkets, which have direct contacts with consumers. A well-designed optimal control scheme, continuously maintaining a commercial refrigeration system at its optimum operation condition, despite changing environmental conditions, will achieve an important performance improvement, both on energy efficiency and food quality reliability.

Many efforts on optimization of cooling systems have been focused on optimizing objective functions such as overall energy consumption, system efficiency, capacity, or wear of the individual components, see [4], [5], [8], [9], [10]. They have proved significant improvements of system performance under disturbances, while there has been little emphasis on the quality aspect of foodstuffs inside display cabinets.

This paper discusses a dynamic optimization of commercial refrigeration systems, featuring a balanced system energy consumption and food quality loss. A former developed quality model of food provides a tool for monitoring the quality loss during the whole process, see [1].

The paper is organized as follows: Operation and modeling of a refrigeration systems is presented in Section II. In Section III the problem formulation used for optimization is introduced. Different optimization schemes and results are presented in Section IV. Finally some discussions and conclusions follow in Section V and Section VI.

## II. PROCESS DESCRIPTION

A simplified sketch of the process is shown in Fig. 1. In

J. Cai and J. Stoustrup are with Automation and Control, Dept. of Electronic Systems, Aalborg University, 9220 Aalborg, Denmark. [jc@es.aau.dk](mailto:jc@es.aau.dk), [jakob@es.aau.dk](mailto:jakob@es.aau.dk)

J. B. Jensen and S. Skogestad are with Dept. of Chemical Engineering, Norwegian University of Science and Technology (NTNU), 7491 Trondheim, Norway. [jorgenba@chemeng.ntnu.no](mailto:jorgenba@chemeng.ntnu.no), [skoge@chemeng.ntnu.no](mailto:skoge@chemeng.ntnu.no)

the evaporator there is heat exchange between the air inside the display cabinet and the cold refrigerant, giving a slightly super-heated vapor to the compressor. After compression the hot vapor is cooled, condensed and slightly sub-cooled in the condenser. This slightly sub-cooled liquid is then expanded through the expansion valve giving a cold two-phase mixture.

The display cabinet is located inside a store and we assume that the store has a constant temperature. The condenser and fans are located at the roof of the store. Condensation is achieved by heat exchange with ambient air.

### A. Degree of freedom (DOF) analysis

There are five DOF (input) in a general simple refrigeration system, see [6]. Four of these can be recognized in Fig. 1 as the compressor speed  $N_C$ , condenser fan speed  $N_{CF}$ , evaporator fan speed  $N_{EF}$  and opening degree (OD) of the expansion valve. The fifth one is related to the active charge in the system.

Two of the inputs are already used for control or are otherwise constrained:

- Constant super-heating (3K): This is controlled by adjusting the OD of the expansion valve.
- Constant sub-cooling (2K): We assume that the condenser is designed to give a constant degree of sub-cooling, which by design consumes the DOF related to active charge, see [6].

So only three DOF are left for optimizing the operation. These are:

- 1) Compressor speed  $N_C$
- 2) Condenser fan speed  $N_{CF}$
- 3) Evaporator fan speed  $N_{EF}$

These inputs are controlling three variables:

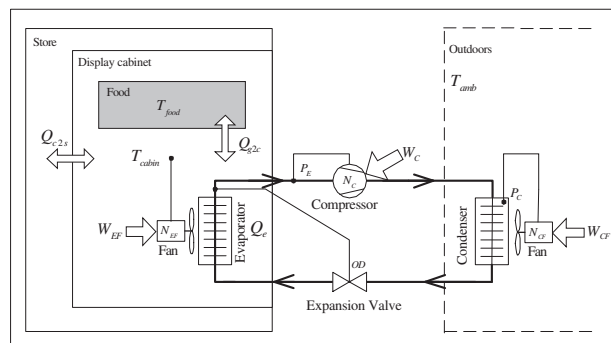

Fig. 1. A simplified supermarket refrigeration system.

TABLE I  
MODEL EQUATIONS

<b>Compressor</b>
$W_C = \frac{m_{ref} \cdot (h_{is}(P_e, P_c) - h_{oe}(P_e))}{\eta_{is}}$
$h_{ic} = \frac{1-f_d}{\eta_{is}} \cdot (h_{is}(P_e, P_c) - h_{oe}(P_e)) + h_{oe}(P_e)$
$m_{ref} = N_C \cdot V_d \cdot \eta_{vol} \cdot \rho_{ref}(P_e)$
<b>Condenser</b>
$W_{CF} = K_{1,CF} \cdot (N_{CF})^3$
$m_{air,C} = K_{2,CF} \cdot N_{CF}$
$T_{aoc} = T_c + (T_{amb} - T_c) \cdot \exp\left(-(\alpha_C \cdot m_{air,C}^{mC}) / (m_{air,C} \cdot C_{p,air})\right)$
$0 = m_{ref} \cdot (h_{ic}(P_e, P_c) - h_{oc}(P_c)) - m_{air,C} \cdot C_{p,air} \cdot (T_{aoc} - T_{amb})$
<b>Evaporator</b>
$W_{EF} = K_{1,EF} \cdot (N_{EF})^3$
$m_{air,E} = K_{2,EF} \cdot N_{EF}$
$T_{aoe} = T_e + (T_{cabin} - T_e) \cdot \exp\left(-(\alpha_E \cdot m_{air,E}^{mE}) / (m_{air,E} \cdot C_{p,air})\right)$
$0 = Q_e - m_{air,E} \cdot C_{p,air} \cdot (T_{cabin} - T_{aoe})$
<b>Display cabinet</b>
$Q_{c2f} = UA_{c2f} \cdot (T_{cabin} - T_{food})$
$Q_{s2c} = UA_{s2c} \cdot (T_{store} - T_{cabin})$
$\frac{dT_{food}}{dt} = (mC_{p,food})^{-1} \cdot Q_{c2f}$
$\frac{dT_{cabin}}{dt} = (mC_{p,cabin})^{-1} \cdot (-Q_{c2f} - Q_E + Q_{s2c})$
$Q_{food,loss} = \int_{t_0}^{t_f} 100 \cdot D_{T,ref} \exp\left(\frac{T_{food} - T_{ref}}{z}\right) dt$

- 1) Evaporating pressure  $P_E$
- 2) Condensing pressure  $P_C$
- 3) Cabinet temperature  $T_{cabin}$

However, the setpoints for these three variables may be used as manipulated inputs in this study so the number of DOF is still three.

### B. Mathematical model

The model equations are given in Table I, see [7] for the modeling of refrigeration systems. Here the refrigerator is assumed to have fast dynamics compared with the display cabinet and food, so for the condenser, evaporator, valve and compressor, steady-state models are used. For the display cabinet and food, a dynamic model is used, as this is where the slow and important (for economics) dynamics will be. The food is lumped into one mass, and the air inside the cabinet together with walls are lumped into one mass. The main point is that there are two heat capacities in series. For the case with constant  $T_{cabin}$ , thus a constant  $T_{food}$ . There are then no dynamics and steady-state optimization may be applied.

Some data for the simulations are given in Table II, see [7] for further data.

### C. Influence of setpoints on energy consumption

As stated above, this system has three setpoints that may be manipulated:  $P_C$ ,  $P_E$  and  $T_{cabin}$ . In Fig. 2, surface shows that under two different  $T_{cabin}$ , the variation of energy consumption with varying  $P_C$  and  $P_E$ . Point A is the optimum for cabinet temperature  $T_{cabin1}$  and point B is the optimum for  $T_{cabin2}$ .  $T_{cabin1}$  is lower than  $T_{cabin2}$ , so the energy consumption is higher in point A than in point B.

TABLE II  
SOME DATA USED IN THE SIMULATION

<b>Refrigerator</b>
min. pressure: $P_{E,min} = 2.0\text{bar}$
max. pressure: $P_{C,max} = 11.0\text{bar}$
max. fan speed: $N_{EF,max} = 60\text{s}^{-1}$
max. fan speed: $N_{CF,max} = 60\text{s}^{-1}$
max. compressor speed: $N_{C,max} = 60\text{s}^{-1}$
<b>Display cabinet<sup>a</sup></b>
heat transfer area $UA_{s2c} = 160\text{WK}^{-1}$
heat capacity: $mC_{p,cabin} = 10\text{kJK}^{-1}$
<b>Food</b>
heat transfer area: $UA_{c2f} = 20.0\text{WK}^{-1}$
heat capacity: $mC_{p,food} = 756\text{kJK}^{-1}$
quality parameter: $D_{T,ref} = 0.2\text{day}^{-1}$ ;
quality parameter: $T_{ref} = 0^\circ\text{C}$
quality parameter: $z = 10^\circ\text{C}$

<sup>a</sup>Combined values for the air inside the cabinet, walls etc.

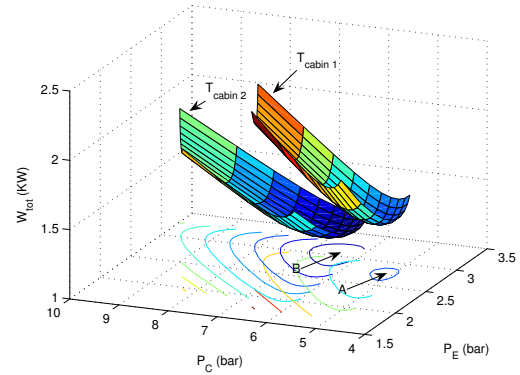

Fig. 2. Energy consumption under different setpoints.

### D. Influence of setpoint on food quality

Food quality decay is determined by its composition factors and many environmental factors, such as temperature, relative humidity, light etc. Of all the environmental factors, temperature is the most important, the other factors are at least to some extent controlled by food packaging.

Here the temperature influence to food quality loss  $Q_{food,loss}$  is investigated. The only setpoint directly influencing  $T_{food}$  (and thus  $Q_{food,loss}$ ) is  $T_{cabin}$ . Fig. 3 shows the daily quality loss for chilled cod product under four cases:  $T_{food}$  of 2, 1°C and  $T_{sin}$ .  $T_{sin,1}$  and  $T_{sin,2}$  are the sinusoidal function with mean value of 1°C, amplitude of 1°C and 3°C respectively, period is 24h. Note that the quality loss is higher with higher temperature, but there is only minor extra loss over 24h by using a sinusoidal temperature with small amplitude. A sinusoidal with large amplitude has a larger influence on quality due to the non-linearity of the quality function, it will not be considered here.

## III. PROBLEM FORMULATION

This study consider at a time horizon of three days, ambient temperature  $T_{amb}$  follows a sinusoidal function with a mean value of 20°C, period of 24h and amplitude of

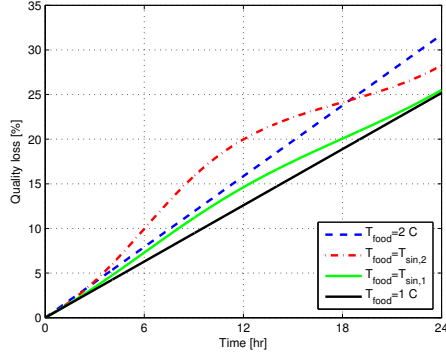

Fig. 3. Fresh fish quality loss when stored at different temperature.

6°C. This is a normal temperature profile in Denmark during summer, see [2].

The objective is to minimize the energy consumption, subject to maintaining a fixed quality loss, by using those three DOF. This can be formulated mathematically as the following:

$$\min_{(N_C(t), N_{CF}(t), N_{EF}(t))} J \quad (1)$$

$$\text{where } J = \int_{t_0}^{t_f} \underbrace{(W_C(t) + W_{CF}(t) + W_{EF}(t))}_{W_{tot}(t)} dt \quad (2)$$

The quality loss of the food could be included in the objective function directly, but this study choose to limit it by using constraints. The optimization is also subjected to other physical and mechanical constraints, such as max. speed of fans and compressor, min. and max. value of evaporator and condenser pressure etc.

In this paper, the food is fresh cod products. Danish food authorities require it to be kept at a max. temperature of 2°C. The control engineer will normally set the temperature setpoint a little lower, for example at 1°C.

**Case 1** Traditional operation with constant  $P_E$ ,  $P_C$  and constant  $T_{cabin} = T_{food} = 1^\circ\text{C}$ .

There are usually large variations in the ambient temperature during the year so in traditional operation it is necessary to be conservative when choosing the setpoint for condenser pressure. To reduce this conservativeness it is common to use one value for summer and one for winter. Here the summer setting is used.

To get a fair comparison with traditional control, which operates at 1°C, the optimization is illustrated by considering the following cases:

**Case 2**  $T_{cabin}$  and  $T_{food}$  constant at 1°C.

Two remaining DOF as functions of time are used for minimizing the energy consumption in 1.

**Case 3**  $\overline{T_{food}} = \frac{1}{t_f - t_0} \int_{t_0}^{t_f} T_{food}(t) dt = 1^\circ\text{C}$ .

Three remaining DOF as functions of time are used for minimizing the energy consumption in 1.

**Case 4**  $Q_{food, loss}(t_f) \leq 75.5\%$ .

Three remaining DOF as functions of time are used for

minimizing the energy consumption in 1. 75.5% is the quality loss at constant temperature of 1°C obtained in Cases 1 and 2.

## IV. OPTIMIZATION

### A. Optimization

The model is implemented in *gPROMS*<sup>®</sup> [3] and the optimization is done by dynamic optimization (except for Case 1). For the Case 2, piecewise linear manipulated variables with a discretisation of every hour are used. For the cases with varying cabinet temperature (Case 3 and 4), sinusoidal functions  $u = u_0 + A \cdot \sin(\pi \cdot t/24 + \phi)$  are used, where  $u_0$  is the nominal input,  $A$  is the amplitude,  $t$  is the time and  $\phi$  is the phase shift.

Using a sinusoidal function has several advantages:

- There are much fewer variables to optimize on, only three for each input, compared with three parameters for each time interval for discrete dynamic optimization.
- There are no end-effects.

In all cases, the phase shift is found to be very small.

### B. Optimization results

Table III compares the four cases in terms of the overall energy  $J$ , end quality loss  $Q_{food, loss}(t_f)$ , max. total power  $W_{tot, max}$  and max. compressor power  $W_{C, max}$ . The two latter variables might be important if there are restrictions on the max. compressor power or on the total electric power consumption.

Some key variables, including speed and energy consumption for compressor and fans as well as temperatures, are plotted for each case in Fig. 5 through Fig. 8.

TABLE III  
TRADITIONAL AND OPTIMAL OPERATIONS

	Case 1	Case 2	Case 3	Case 4
$J$ [MJ]	273.7	242.8	240.7	241.4
$Q_{food, loss}(t_f)$ [%]	75.5	75.5	76.1	75.5
$W_{C, max}$ [W]	955	1022	836	879
$W_{tot, max}$ [W]	1233	1136	946	981

For Case 1 (traditional operation) the total energy consumption over three days is 273.7MJ. Note that the condenser temperature (and pressure) is not changing with time.

If  $T_{cabin} = T_{food}$  is kept constant at 1°C, but the pressures (and temperatures) in the condenser and evaporator are allowed to change with time (Case 2), the total energy consumption can be reduced by 11.3% to 242.8MJ. Fig. 6 shows that the evaporator temperature is constant, because the cabinet temperature is still controlled, while the condenser temperature varies with ambient temperature. The quality is the same as in Case 1 because of the constant cabinet temperature. The power variations are larger, but nevertheless,  $W_{tot, max}$  is reduced by 7.9% to 1136W.

Next, the  $T_{cabin}$  is also allowed to vary, but a constraint is added on the average food temperatures  $\overline{T_{food}} = 1.0^\circ\text{C}$  (Case 3). This reduces the total energy consumption with another

0.9%, while the food quality loss is slightly higher. Note from Fig. 7 that the evaporator, cabinet and food temperature is varying a lot.

Finally, in Case 4 the quality loss is restricted. With  $Q_{\text{food,loss}}(t_f) \leq 75.5\%$ , which is the same end quality loss as for Case 1, a saving of 11.8% on energy compared with Case 1 is realized. Note from Fig. 8 that the amplitude for food, cabinet and evaporator temperature are slightly reduced compared to Case 3.

An important conclusion is that most of the benefit in terms of energy savings is obtained by letting the setpoint for  $P_E$  and  $P_C$  vary (Case 2). The extra savings by varying also  $T_{\text{cabin}}$  (Case 3 and 4) are small. However, the peak value for compressor power and total system power is significantly decreased for Case 3 and 4. This is also very important, because a lower compressor capacity means a lower investment cost, and a lower peak value of total power consumption will further reduce the bill for supermarket owner, according to the following formula:

$$C_{\text{op}} = \int_{\text{month}}^{\text{year}} (P_{\text{el}}(t) \cdot E_{\text{el}}(t) + \max(P_{\text{el}}(t)) \cdot E_{\text{el,dem}}(t)) dt \quad (3)$$

Where  $C_{\text{op}}$  is the operating cost,  $E_{\text{el}}$  is the electricity rate,  $P_{\text{el}}$  is the electric power,  $E_{\text{el,dem}}$  is the electricity demand charge,  $\max(P_{\text{el}}(t))$  is the max. electric power during one month.

### C. Trade-off between energy consumption and food quality loss

Fig. 4 plots the Pareto optimal curve between the average daily food quality loss and energy consumption. It shows that reducing quality loss and saving energy is a conflicting objective to a system. An acceptable tradeoff between these two goals can be selected by picking a point somewhere along the line. It also shows that Case 1 is far away from optimization; Case 4 is one optimal point, while Case 2 and 3 are near optimal solutions.

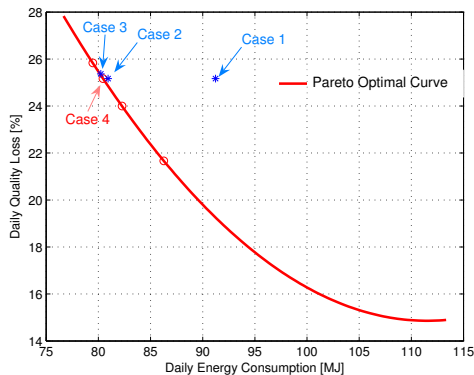

Fig. 4. Optimization between food quality loss and energy consumption.

## V. DISCUSSION

Having oscillations in the pressures will impose stress and cause wear on the equipment. This might not be desirable

in many cases, but in this study the oscillations are with a period of one day, so this should not be an issue.

Experiments on the influence of fluctuating temperatures on food quality were reviewed by [11], where marginal reduction in final quality due to fluctuations was reported. In our case, food temperature is only slowly varying, and with an amplitude of less than 1°C. Thus, this will not pose any negative influence on food quality.

## VI. CONCLUSION

This study has shown that traditional operation where the pressures are constant gives excessive energy consumption. Allowing for varying pressure in the evaporator and condenser reduces the total energy consumption by more than 11%. Varying food temperature gives only minor extra improvements in terms of energy consumption, but the peak value of the total power consumption is reduced with an additional 14% for the same food quality loss.

Reducing quality loss and saving energy is a conflicting objective. Our optimization result will help the engineer to select an acceptable tradeoff between these two goals by picking a point somewhere along the Pareto front line.

This paper investigates the potential of finding a balancing point between quality and energy consumption, by open-loop dynamic optimizations. It uses the sinusoid ambience temperature as one example. In real life, weather patterns are not exactly a sinusoidal function, but real weather conditions can be easily obtained in advance from forecast. Practical implementation, including selecting controlled variables and using closed-loop feedback control, will be the theme of future research.

## REFERENCES

- [1] J. Cai, J. Risum, and C. Thybo. Quality model of foodstuffs in a refrigerated display cabinet. Purdue, USA, 2006. 11th Int. Refrigeration and Air Condition Conference.
- [2] DMI. <http://www.dmi.dk>. 2007.
- [3] gPROMS. <http://www.psenterprise.com/gproms/index.html>. 2008.
- [4] A. Jakobsen and B. D. Rasmussen. Energy-optimal speed control of fans and compressors in a refrigeration system. *Eurotherm 62*, pages 317–323, 1998.
- [5] A. Jakobsen, B. D. Rasmussen, M. J. Skovrup, and J. Fredsted. Development of energy optimal capacity control in refrigeration systems. Purdue, USA, 2001. In proc.: Int. refrigeration conference.
- [6] J. B. Jensen and S. Skogestad. Optimal operation of simple refrigeration cycles. Part I: Degrees of freedom and optimality of sub-cooling. *Comput. Chem. Eng.*, 2007.
- [7] L. F. S. Larsen. *Model based control of refrigeration system*. PhD thesis, Department of Control Engineering, Aalborg University, Denmark, 2005.
- [8] L. F. S. Larsen and C. Thybo. Potential energy saving in refrigeration system using optimal setpoint. Taipei, Taiwan, 2004. In proc.: IEEE Conference on control applications.
- [9] D. Leducqa, J. Guilparta, and G. Trystramb. Non-linear predictive control of a vapour compression cycle. *Int. J. Refrigeration*, 29:761–772, 2006.
- [10] M. C. Swensson. *Studies on on-line optimizing control, with application to a heat pump*. PhD thesis, Department of Refrigeration Engineering, NTNU, Norway, 1994.
- [11] R. Ulrich. Variations de temperature et qualite des produits surgelés. *Review Generale due Froid*, 71:371–389, 1981.

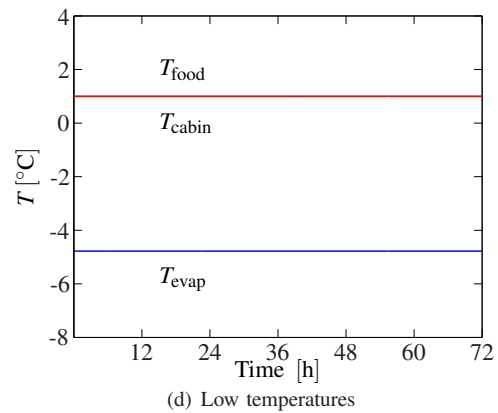
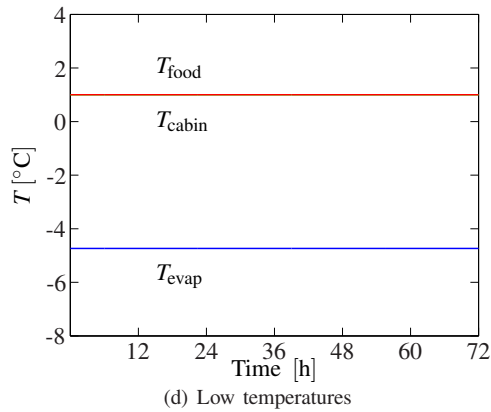
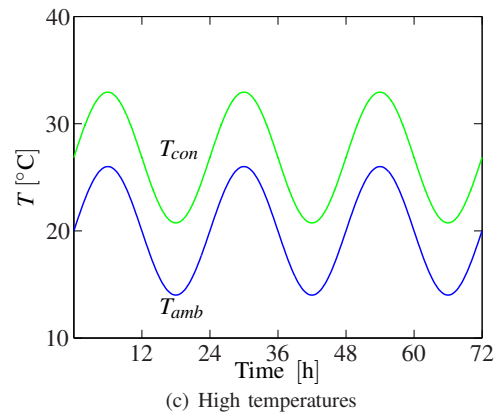
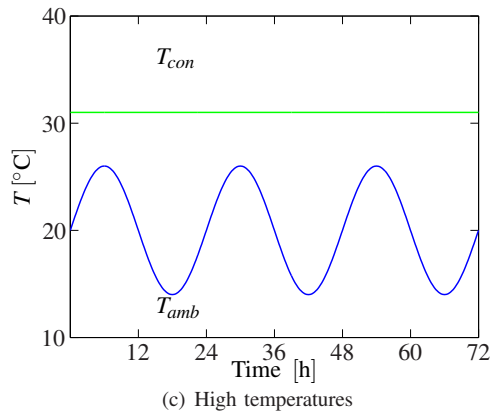
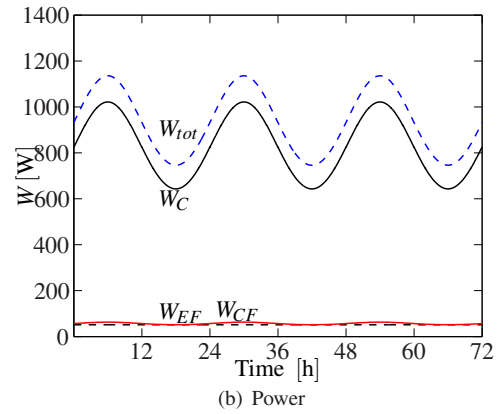
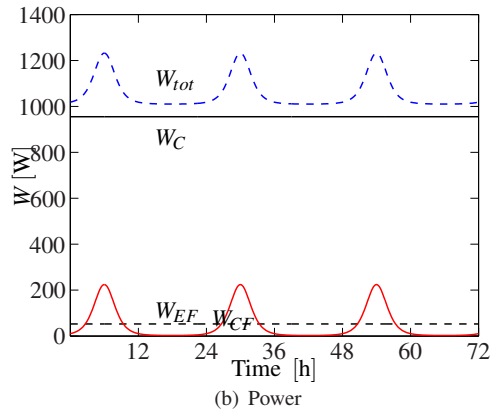
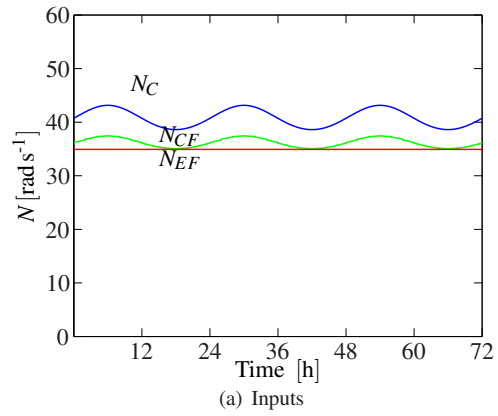
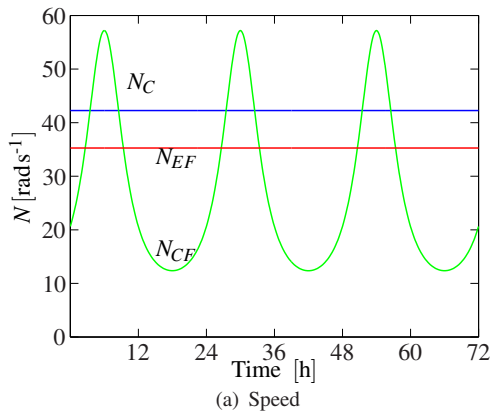

Fig. 5. Traditional operation with  $T_{\text{cabin}} = 1^\circ\text{C}$ ,  $P_E = 2.4\text{bar}$  and  $P_C = 8.0\text{bar}$  (Case 1).

Fig. 6. Optimal operation for  $T_{\text{cabin}} = 1^\circ\text{C}$  (Case 2).

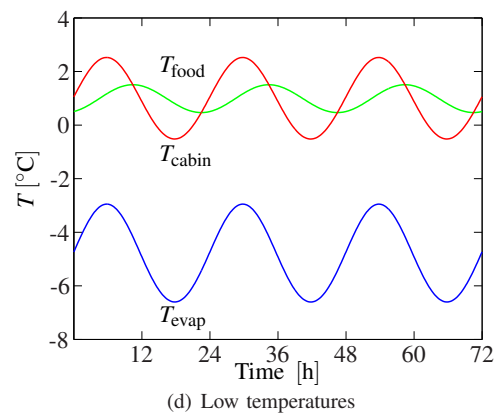
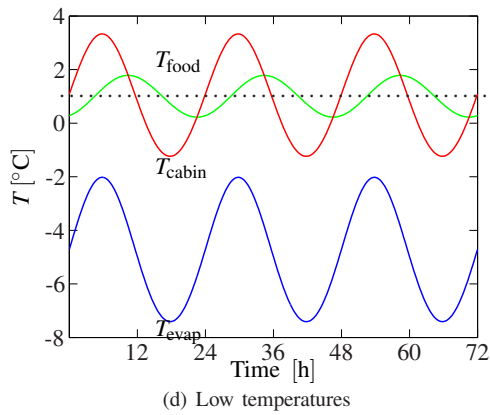
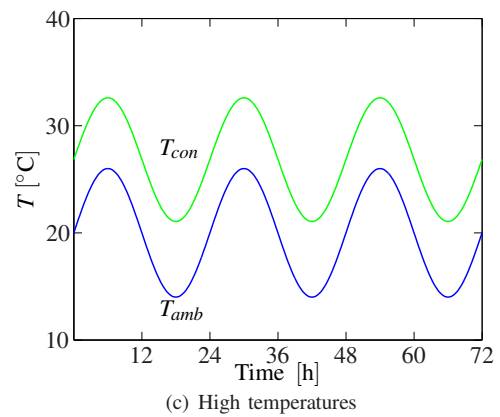
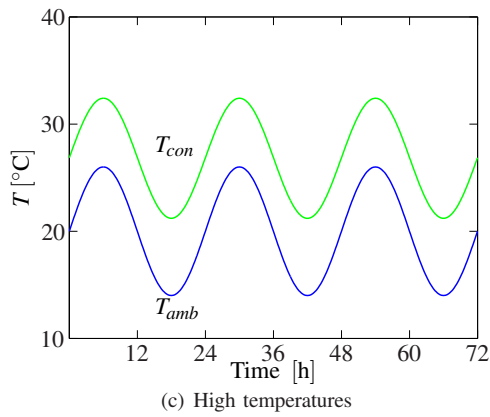
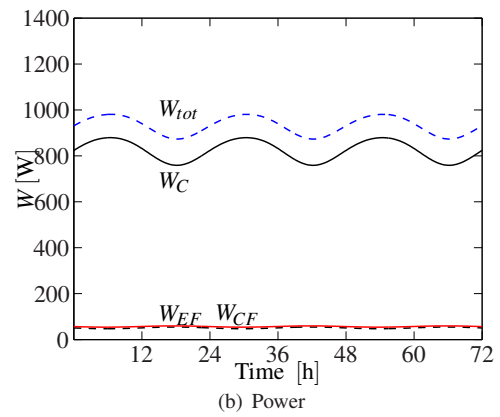
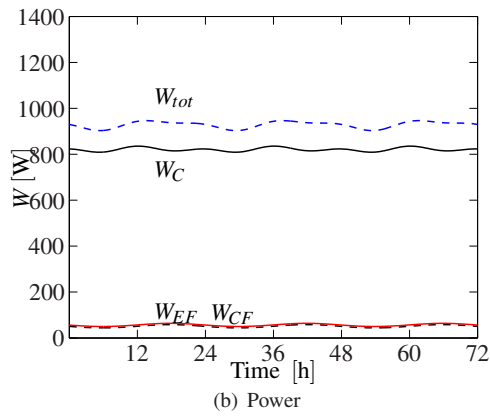
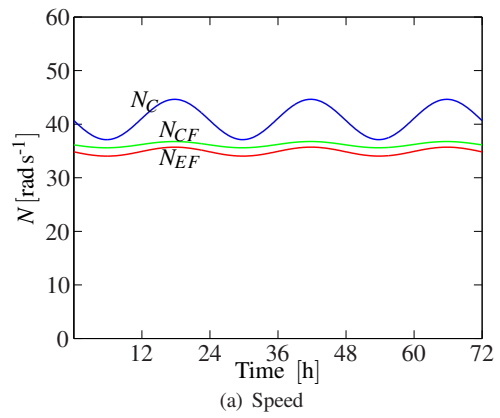
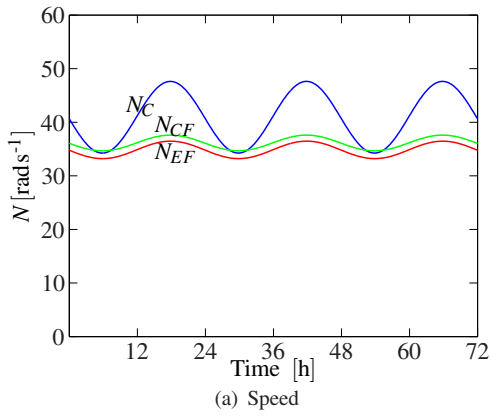

Fig. 7. Optimal operation for  $\bar{T}_{\text{food}} = 1^\circ\text{C}$  (Case 3).

Fig. 8. Optimal operation for  $Q_{\text{food}} \leq 75.5\%$  (Case 4).