

Multivessel Batch Distillation - Potential Energy Savings

Bernd Wittgens and Sigurd Skogestad ¹

Norwegian University of Science and Technology (NTNU),
Department of Chemical Engineering,
7034 Trondheim, Norway

ABSTRACT - A conventional batch distillation column operated under feedback control applying the proposed policy is compared to the multivessel batch distillation column. In some cases we found that an increase in production rate up to 50 % is possible by using multivessel batch distillation instead of a conventional batch distillation column with similar column length. Besides the considerable reduction in energy usage, the main advantage with the multivessel batch distillation column is probably its much simpler operation compared to a conventional batch distillation column.

INTRODUCTION

Although batch distillation generally is less energy efficient than continuous distillation, it has received increased attention in the last few years because of its simplicity of operation, flexibility and lower capital cost. Batch distillation columns schemes have been extended with middle vessels (Robinson and Gilliland, 1950) which result in a configuration with rectifying and stripping section (Bortolini and Guarise 1970). Recently, one has started re-examining the operation as batch distillation as a whole to find the most favorable operation procedure for a given (*e.g.*: two component) separation problem (*e.g.*: Sørensen and Skogestad, 1994).

A new type of batch distillation column and operation strategy for separation of multicomponent mixtures was proposed by Hasebe *et al.* (1995) and has been further studied by the authors (Skogestad *et al.* 1997 and Wittgens *et al.* 1996). For the separation of an N_c -component mixture only one reboiler and condenser and $N_c - 2$ intermediate vessels as well as $N_c - 1$ -column sections are needed. Normally, the unit is operated under total reflux. The primary feature of this configuration is that the energy required to separate the mixture is considerably less than in conventional batch distillation due to heat integration of several column sections. Hasebe *et al.* (1995) indicates that the energy efficiency of a multivessel batch distillation could be comparable to continuous distillation. Recently, renewed interest evolved on integrated column configurations for multicomponent separations in a single unit.

In this paper we compare conventional batch distillation columns with multivessel batch distillation with respect to ease of operation and productivity (energy efficiency).

CONVENTIONAL BATCH DISTILLATION

The optimization of a conventional batch column (Fig. ??) leads to an optimal control problem, for which problem formulation and numerical solution methods are not yet well established (Machietto and Mujtaba, 1992). Results from optimization studies have shown an increased performance of the column using an optimal reflux policy, compared to the conventional constant reflux policy or constant distillate composition policies time and energy savings in the order of 20 % dependent on the mixtures separated have been reported (Sørensen, 1994). However, more recent results (Sørensen, 1994 and this work) indicates much bigger savings in some cases. Nevertheless, the implementation of an optimal reflux policy is not yet widely used in industries, while piecewise constant reflux policies are applied (Diwekar *et al.*, 1987). Industrial batch columns are operated often with a rather simple reflux policy *e.g.*: the number of off-cuts are predefined and the reflux ratio is constant during operation. However, at least for multicomponent mixtures, this policy is difficult to implement, and one must often take off a large number of products, which are later, after composition analysis, blended to give the appropriate products. Also, it is not optimal to keep a constant reflux ratio (*e.g.*: high reflux ratio to fulfill the product specifications), so the production time may be much longer than is needed.

¹Author to whom correspondence should be addressed, fax: +47 7359 4080; E-mail: skoge@chembio.ntnu.no

Another operation policy, which usually is better in terms of energy consumption (production time) is to use a feedback control scheme, which keeps the product composition at a desired value. In practice, composition may be difficult (time consuming) and expensive to measure, so we will here instead keep the temperature at a given position of the column constant, thus indirectly control the top product composition (see Fig. ??). Change-over between products may take place when the reflux flow L increases above a predefined limit. At this time one normally needs to produce an off-cut fraction and one may, for example, when the next temperature setpoint is reached switch to the second product. This procedure is performed until $N_c - 1$ product fractions are withdrawn over top, finally, the last product is withdrawn from the reboiler.

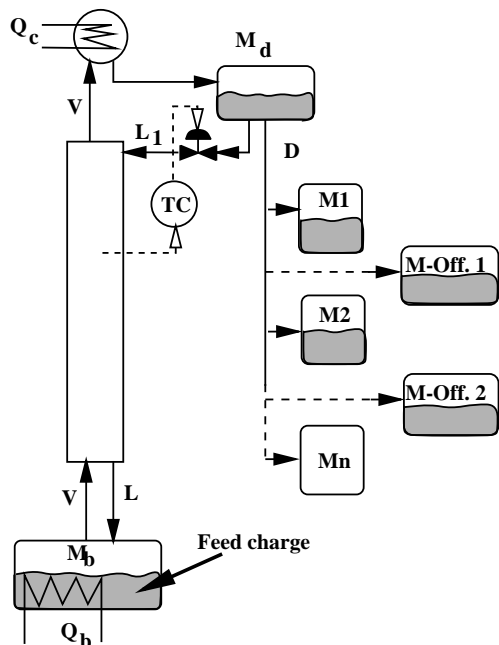

Figure 1: Conventional batch distillation, one component at a time over top

MULTIVESSEL BATCH DISTILLATION

For the separation of a mixture containing N_c -components, the multivesel batch distillation column consists of $N_c - 1$ column sections, reboiler, condenser/accumulator and $N_c - 2$ -intermediate vessels. The simplest strategy for operating the multi-vessel column, is the *total reflux operation* suggested by Hasebe *et al.* (1995) where the N_c product rates are set to zero ($D_i = 0$). There are at least two advantages with this multivesel column compared to conventional batch distillation where the products are drawn over the top, one at a time. First, the operation is simpler since no product change-overs are required during operation. Second, the energy requirement may be much less due to the multi-effect nature of the operation. For the total reflux operation of the multivesel column, a feedback control structure based on $N_c - 1$ temperature controllers (see Fig. ??) has been proposed by Skogestad *et al.* (1996). The idea is to adjust the reflux flow out of each of the upper $N_c - 1$ vessels by controlling the temperature at some location in the column section below. There is no explicit level control, rather the holdup, M_i , in each vessel is adjusted indirectly by varying the reflux flow to meet the temperature specifications and thus product quality requirements.

SIMULATION MODEL

All the results in this paper are based on simulations using the dynamic model described in the paper by Skogestad *et al.* (1997). We have made a number of simplifying assumptions, such as constant molar flows, constant relative volatilities $\alpha_j = [10.2, 4.5, 2.3, 1]$, where the numerical values of the relative volatility are chosen to be close to those of the system methanol-ethanol-1-propanol-1-butanol. Assuming constant stage holdup, perfect level control and constant pressure simplify the column model considerably. We assume a linear boiling point curve, that is the tray temperature is the molar average of the boiling temperatures of the pure components ($T_i = \sum_{k=1}^{N_c} x_k \cdot T_{B,k}$ with $T_{B,k} = [64.7, 78.3, 97.2, 117.7]^\circ\text{C}$). The dynamic model is implemented using the SPEEDUP software package (Speedup, 1993).

OPERATION POLICIES

Conventional batch distillation

Even though the separation of multicomponent mixtures by means of batch distillation is investigated for an extensive time, we did not find any simple operation procedures in the literature. We decided the following procedure based on temperature measurements, which is aimed at achieving, for each product, an approximately constant overhead composition, somewhat better than its specification.

The feedback control strategy is based on the following ideas:

- A sensor is located a few stages below the column top such that a break-through of heavier components into the product is easily avoided. The setpoint is set to be somewhat above the boiling point of the product

$$T_{S,j}^i = T_b^i + \Delta T \quad (1)$$

where i is the stage location (counted from the top) and j is the index for the main component. The second term ΔT in Equation (??) accounts for the temperature increase along the column considering the location of the sensor below the column top. ²

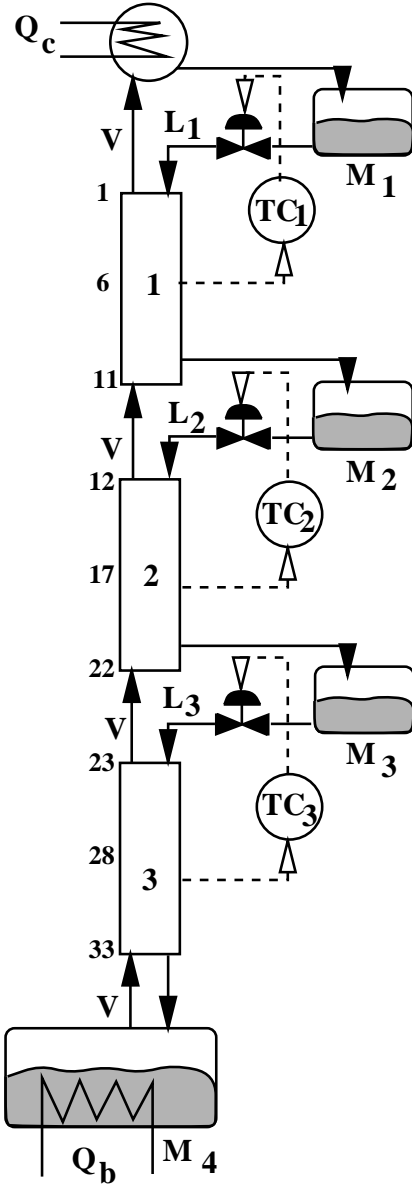

Figure 2: Multivessel Batch Column under feedback control

- The change-over temperature $T_{off,j}$ for the collection of off-cut product j is determined from the boiling point of the next product fraction (product $j + 1$). We define:

$$T_{off,j}^i = T_{S,j+1} + \Delta T_{off} \quad (2)$$

where ΔT_{off} ensures that most of the component lighter than key component in the next product is removed from the column.

Operation of a conventional batch column with the above described policy to determine temperature setpoints as well as change-over temperatures is as follows:

1. Start-up from total reflux operation (not included in the simulation).
2. After establishing a composition profile, the temperature controller TC (see Fig. ??) is activated and adjust the reflux L to keep the temperature on the control tray T^i at its setpoint $T_{S,1}^i$. If the reflux L reaches its maximum $L \geq L_{max}$, the collection of product 1 is finished.
3. During the next cycle, an off-cut fraction is withdrawn from the column. The column is operated off-line (feedback control deactivated) with a constant low reflux, L_{off} , until the change-over temperature $T_{off,1}^i$ (see Eq. ??) is reached.
4. Withdrawl of product 2 is performed, by activating the temperature controller which hold the temperature on the control tray at its given setpoint $T_{S,2}^i$ (see Eq. ??). (Note that the change-over from off-cut 1 to product 2 is performed at a temperature *higher* than the desired setpoint for the withdrawl of product 2 that is: $T_{off,1}^i > T_{S,2}^i$. The latter is to avoid that the lower initial temperature caused by light component remaining results in excessive amount of heavy component.) Again, collection of product 2 is finished when the maximum reflux is reached, $L \geq L_{max}$.
5. Off-cut 2 is withdrawn until temperature $T_{off,2}^i$ is reached, again slightly above the temperature setpoint of the third product fraction.

²Note: One may view ΔT to consist of the two terms $\Delta T^i = \Delta T_{composition}^i + \Delta T_{location}^i$, where $\Delta T_{composition}^i \approx (T_b^{heavy} - T_b^{product})_{x^{heavy}}$ takes into account that we allow for some heavy component in the product. The second term $\Delta T_{location}^i$ takes into account that the temperature increases down the column. $\Delta T_{composition}^i$ can be computed beforehand, $\Delta T_{location}^i$ must be determined from either simulation or experiment.

This cycling between production and off-cut withdrawal is performed until all products are produced. After the batch is finished, one may, based on composition analysis of the products and off-cut fractions, blend off-cuts into the products (especially if the off-cut is large) so that they exactly meet their specifications and to maximize the production rate. This was not done when computing the production rate given in Table ??.

Multivessel batch distillation

The operation of the multivessel batch column (see Fig. ??) is rather simple, as explained in section ?. The three PI-temperature controllers are activated immediately after start-up (e.g.: total reflux operation), and the column is operated in this manner until the last of the four products reaches its specification. (In practice, the column is operated under feedback control until the changes in reflux flows and temperature are small.)

RESULTS

In the here presented work we compare a conventional batch distillation with the here proposed feedback operation policy and a multivessel batch distillation. Column design and operational data are given in the Appendix.

We compare the energy usage in the sense of the net production rate for a given, fixed boilup ($V = 10 \text{ kmol/h}$) defined as $(F - D_{off}) / t_b$ with $F = 10 \text{ kmol}$ as initial feed charge, D_{off} as sum of off-cut and (if present) non-spec products and t_b as the batch time, which was required to achieve all of the product specifications.³ Further, we require that the impurities of the intermediate products N_c are distributed such that their ratio is $x_{N_c-1} / x_{N_c+1} \approx 1$. The results are presented in Table ?. Further in Figures ? and ? we show the composition profiles, controlled temperatures in the column sections, reflux flow as well as the holdup in the product tanks for the two operation policies (note the different time scales).

For the conventional batch distillation we note that the net production rate is not increased, when the number of stages is increased from 15 to 33. Of course, it should be possible to increase the production rate by adding stages, so the result illustrates the difficulty in operating conventional batch distillation, especially for multicomponent mixtures with off-cut. The increase in column length of the conventional batch column has opposing effects on the productivity. The product purities are increasing further above specification and batch time decreases, simultaneously the amount of off-cut D_{off} increases. The latter effect cancels the effect of batch time reduction, such that the production rate is unchanged, even though the column length increases.

Table 1: Product composition and amount, batch time and production rate of batch distillation processes (fixed vapor flow $V = 10 \text{ kmol/h}$)

	N_T		product				M_{off}	t_b [h]	net production [kmol/h]
			M1	M2	M3	M4			
conventional batch	15	M [kmol]	2.54	2.26	2.13	2.43	0.64	4.31	2.17
		x_{main}	0.987	0.956	0.965	0.985			
	33	M [kmol]	2.68	1.99	1.89	2.28	1.15	4.01	2.17
		x_{main}	0.988	0.988	0.973	0.986			
multivessel batch	3×11	M [kmol]	2.50	2.44	2.54	2.52	0.0	3.38	2.96
		x_{main}	0.993	0.963	0.950	0.993			
	3×15	M [kmol]	2.51	2.44	2.56	2.49	0.0	2.48	4.03
		x_{main}	0.999	0.973	0.950	0.999			
	3×19	M [kmol]	2.52	2.45	2.55	2.49	0.0	2.33	4.29
		x_{main}	0.999	0.973	0.950	0.999			

Note that we have not blended the off-cut into the product. If we blend the combined off-cut product (all off-cut fractions are accumulated in one tank) into the four products to exactly meet the specifications, the net production rate of the conventional batch column would increase by less than 10 %.

For the multivessel batch distillation column the production of off-cut is negligible (actually, the remaining hold-up in the column sections could be seen as off-cut). The separation of the feed mixture is performed with considerable less time and thus energy consumption (see Table ?). Increasing the length of the column sections

³Note, that the batch time does not include charging of the column, preheating, start-up under total reflux and shutdown.

give some improvement in product quality, but since, at least one, of the components is at the specification, batch time decreases considerably.

For columns of identical length ($\sum N_T = 33$), the given separation consumes approximately 30 % less energy in the multivessel column compared to the conventional column. Further, since no off-cut is produced, an increase of production rate in the order of 40 % was found. Increasing the length of the column sections of the multivessel column from 11 to 19 trays each, the production rate increases by approximately 40 %.

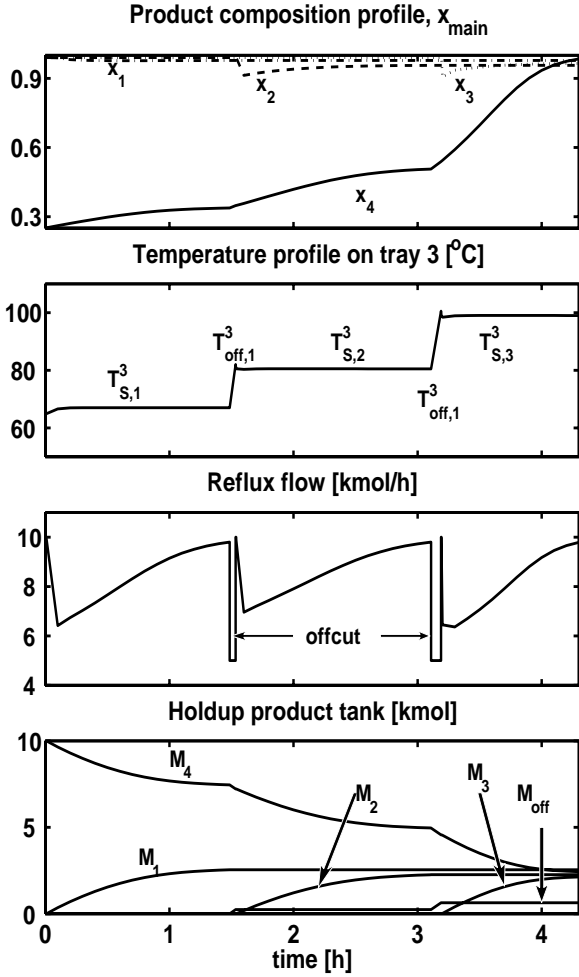

Figure 3: Product composition profile, controlled temperature, reflux flow and holdups of products for conventional batch distillation

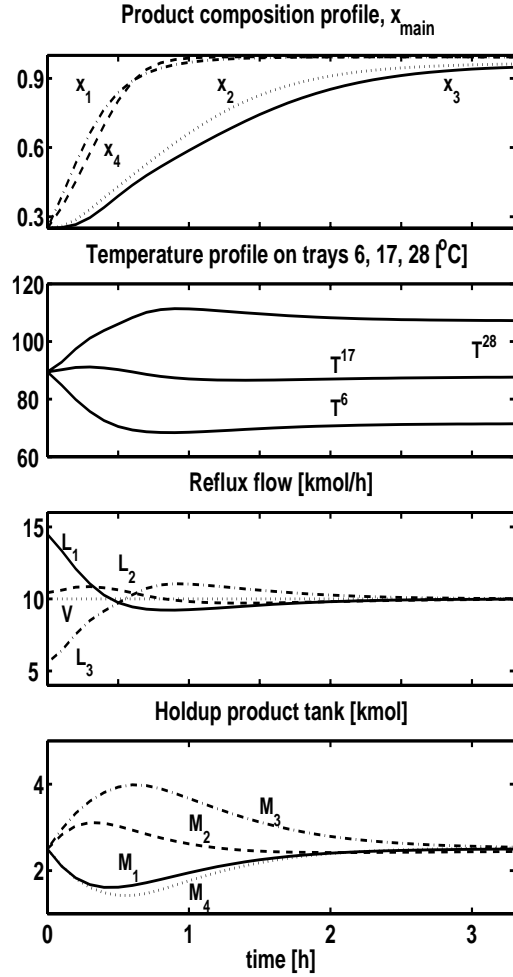

Figure 4: Product composition profile, controlled temperatures, reflux flows and holdups of products for multivessel batch distillation

DISCUSSION

For the example studied in this paper, we achieved increases in production capacity of up to 98 % or equivalent, a reduction of energy consumption of approximately 50 %. Although the results for the conventional batch distillation column may be quite far from the optimal reflux policy, they are probably better than they can be expected from industrial practice. Note that a constant reflux policy, commonly used in industry, would yield significantly worse results.

Besides the considerable reduction in energy usage, the main advantage with the multivessel batch distillation is probably its much simpler operation compared to a conventional batch distillation column. It may be operated easily without operator intervention, whereas conventional batch distillation requires product and off-cut changeovers as well as adjustments of reflux or alternatively: temperature setpoints. It can be automated, *e.g.*: using the procedure proposed in this paper, but still operators would be needed for cases where something fails.

Further, the net production rate of more than 4 kmol/h for the multivessel batch distillation column is comparable to what can be achieved with the same energy input in a conventional direct sequence of continuous distillation columns (without energy integration).

ACKNOWLEDGEMENTS

The authors would like to thank undergraduate students S. Eng, K. Kaas and S. Selberg for their contributions.

LITERATURE CITED

1. Bortolini, P. and Guarise, G.B., "Un nuovo metodo di distillazione discontinua (In Italian; A new practice of Batch Distillation)", *Quad. Ing. Chim. Ital.*, Vol. 6, No. 9, p. 150-159, 1970.
2. Diwekar, U.M., R.K. Malik, K.P. Madhavan, "Optimal reflux rate policy, Determination for Multicomponent Batch Distillation", *Comp. Chem. Eng.*, Vol. 11, pp. 629-637, 1987
3. Gmehling J. and U. Onken, "Vapor-Liquid Equilibrium Data Collection", Vol. I, Part 2a, Dechema, Frankfurt, 1977
4. Hasebe, S.; T. Kurooka and I. Hashimoto, "Comparison of the separation performances of a multi-effect batch distillation system and a continuous distillation system", *Proc. IFAC-symposium DYCORDER'95*, Denmark, June 1995.
5. Robinson, C.S. and E.R. Gilliland, "Elements of Fractional Distillation", *McGraw Hill Book Company*, New York, 4th ed., 1950
6. Skogestad, S. Wittgens, B., and Sørensen, E., "Multivessel Batch Distillation", *AIChE-Journal*, Vol. 43, No.4, p. 971, 1997
7. Sørensen, E. and S. Skogestad, "Optimal operating policies of batch distillation", *Proc. Symposium PSE'94*, Kyongju, Korea, June 1994, 449-456.
8. Wittgens, B., Litto, R., Sørensen, E. and S. Skogestad, "Total Reflux Operation of Multivessel Batch Distillation", *ESCAPE-96, Comp. Chem. Engng.*, Vol. 20, S1041-1046, 1996

APPENDIX

The product specifications are given as lower bounds on the purity of the maincomponent in all four products $x_D = [0.98, 0.95, 0.95, 0.98]$. The columns operate with a constant vapor flow of $V = 10 \text{ kmol/h}$ and an initial feed charge of $F = 10 \text{ kmol}$ with a composition of $z_F = [0.25, 0.25, 0.25, 0.25]$.

The location of the temperature sensor applied for feedback control of the conventional batch column is chosen to be at a distance of 0.2 N_T from the column top, the sensor is located on tray 3 for the column with 15 stages and 6 for 33 stages. For the conventional column equipped with 15 trays we choose $\Delta T \approx 2^\circ C$, in the case of 33 trays $\Delta T \approx 4^\circ C$, to account for sensor location and amount of heavy component in the product. The temperature offset to remove light component during off-cut production is for both columns chosen to be $\Delta T_{off} \approx 1.5^\circ C$. The boiling points of the products are computed to be $T_{b,j} = [64.97, 78.43, 97.23, 117.29]$, these temperatures are used to compute controller setpoints $T_{S,j}^i$ and changeover temperatures $T_{off,j}^j$ shown in Table ?? . A PI-controller with gain $K_c = -0.5 \text{ kmol}/^\circ C$ and integral action $\tau_I = 0.05 \text{ h}$ is chosen. The reflux flow during production phase is $2 \leq L \leq 9.8 \text{ kmol/h}$ while during off-cut withdrawl the reflux flow is constant at $L_{off} = 5 \text{ kmol/h}$.

The sensor for the multivessel batch distillation column are located in the middle of each section. Controller setpoints are determined from $T_i^{S,j} = (T_{B,k} + T_{B,k+1})/2$, with $T_{B,k}$ as the boiling point of pure component k . The controller parameter are chosen to $K_c = -0.25 \text{ kmol}/^\circ C$ and $\tau_I = 0.05 \text{ h}$. The reflux flow controlled within $5 \leq L \leq 15 \text{ kmol/h}$.

Table 2: Controller setpoints $T_{S,j}^i$ and changeover temperatures $T_{off,j}^j$ for fixed vapor flow $V = 10 \text{ kmol/h}$

column type	section length N_T	sensor location i	prod. D1 $T_{S,1}^1$	1. offcut $T_{off,1}^1$	prod. D2 $T_{S,2}^1$	2. offcut $T_{off,2}^1$	prod. D3 $T_{S,3}^1$	3. offcut $T_{off,3}^1$
conventional	15	3	67	82	80.5	100.5	99	113
	33	6	69	83.5	82	102.5	101	113
multivessel	11	6	71.5		87.75		107.2	
	15	8						
	19	10						