

Stable Teleoperation with Time Domain Passivity Approach

Jee-Hwan Ryu *

* School of Mechanical Engineering, Korea University of Technology
and Education, Cheonan, R. of Korea (Tel: +82-41-560-1250; e-mail:
jhryu@kut.ac.kr).

Abstract: In this paper, performance of recently modified two-port time-domain passivity approach is evaluated under serious time-varying communication delay. First, recently proposed two-port time-domain passivity approach is reviewed. A packet reflector with wireless internet connection is used to introduce serious time-varying communication delay of teleoperators. Average amount of time-delay was about 180(msec) for round trip, and varying between 175(msec) and 275(msec). Moreover some data packet was lost during the communication due to UDP data communication. Even under the serious time-varying delay and packet loss communication condition, the proposed approach can achieve stable teleoperation in free motion and hard contact as well.

1. INTRODUCTION

Teleoperation is one of the first domain of robotics and has been one of the most challenging issue [17]. In teleoperation, a human operator conducts a task in a remote environment via master and slave manipulators. With the progress of computer network, teleoperation is getting considerable attention again [3] because of its potential applications including tele-surgery, tele-maintenance and welfare.

When a robot is operated remotely by use of a teleoperator, force feedback can considerably improve an operator's ability to perform complex tasks by kinesthetically coupling the operator to the environment. However, any data communication over the computer network has communication time-delay. In the presence of communication time-delay, even though it is small, force feedback has strong destabilizing effect [16].

There have been numerous research for solving the time-delay problem in bilateral control of teleoperators. Based on the scattering theory, Anderson and Spong [1] proposed a bilateral control law that maintains stability under the communication time-delay. Niemeyer and Slotine [7] extended this idea, and introduced the notion of "wave variable". Even the wave variable method was successful, it assumed constant time-delay. Several approaches extended the original wave variable method to the case when there is time-varying communication delay [5, 8, 20].

There were also several other approaches. Leung [6] proposed a bilateral controller for time-delay based on the H_∞ optimal controller and μ -synthesis frameworks. Oboe and Fiorini [9] dealt with the time-varying delay problem over the internet by using a simple PD-type controller. Sano [15] proposed a gain-scheduled H_∞ controller using measured time-delay.

However, the problem of previous approaches was the conservatism. The passivity was guaranteed with the expense

of too much degradation of the system performance. For solving this performance and stability issue Hannaford and Ryu have proposed a new concept of energy based approach. This idea has been successfully applied for guaranteeing the passivity of haptic [4] and teleoperation systems with no communication time-delay [10]. Recently this idea has been extended for stable bilateral control of teleoperators including time-varying communication delay [14].

In our previous paper, teleoperation experiments with about 120 (msec) of time-delay each way have been performed, and the newly proposed controller has achieved stable teleoperation in free motion and hard contact as well. However, the amount of time delay was not actually fluctuating that much, and there are almost no packet loss in our previous experimental condition. In this paper, we prove the performance of the recently proposed approach by introducing more serious time-varying delay and data packet loss communication condition.

2. REVIEW OF THE TIME DOMAIN PASSIVITY APPROACH

2.1 Time Domain Passivity Observer and Controller

The following widely known definition of passivity was used.

Definition 1: The one-port network (Fig. 1), N , with initial energy storage $E(0) = 0$ is *passive* if and only if,

$$\int_0^t f(\tau)v(\tau)d\tau \geq 0, \quad \forall t \geq 0 \quad (1)$$

holds for admissible forces (f) and velocities (v), where their product is defined to be positive when power enters the system port. Eqn (1) states that the energy supplied to a passive network must be positive for all time [18], [19].

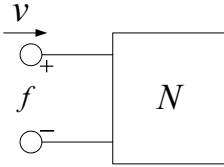

Fig. 1. One-port network system representing components. The conjugate variables that define power flow in such a network system are discrete-time values, and the analysis was confined to systems having a sampling rate substantially faster than the dynamics of the system. Thus, we could easily “instrument” one or more blocks in the system with the following “Passivity Observer,” (PO) for a one-port network to check the passivity (1).

$$E_{obsv}(t_k) = \Delta T \sum_{j=0}^k f(t_j)v(t_j) \quad (2)$$

where ΔT is the sampling period, and $t_j = j \times \Delta T$. If $E_{obsv}(t_k) \geq 0$ for every k , this means the system does not generate energy. If there is an instance when $E_{obsv}(t_k) < 0$, this means the system generates energy and the amount of generated energy is $-E_{obsv}(t_k)$.

Consider a one-port system which may be active. Depending on operating conditions and the specifics of the one-port element’s dynamics, the PO may or may not be negative at a particular time. However, if it is negative at any time, we know that the one-port may then be contributing to instability. Moreover, since we know the exact amount of the generated energy, we can design a time-varying damping element to dissipate only the required amount of energy. We call this element a “Passivity Controller” (PC). The PC takes the form of a dissipative element in a series or parallel configuration depending on the input causality [4]. Fig. 2 shows the series configuration of the PC for an one-port network system. α is an adjustable damping element at the port. Choice of configuration depends on input/output causality of model underlying each port.

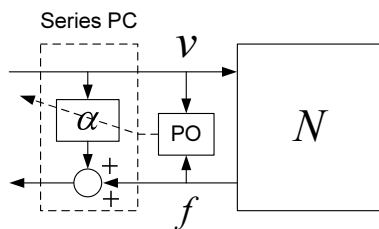

Fig. 2. Series configuration of passivity controller for an one-port network system.

2.2 Time Domain Passivity Approach for Teleoperation Systems Without Time-delay

Fig. 3 shows a network model of a teleoperation system, where v_h and v_e denote the velocities at the interacting points of the human/master and environment/slave, respectively, and f_h and f_e represents the force that the operator applies to the master manipulator and the slave manipulator applies to the environment, respectively.

It is well known fact that the teleoperator two-port should be passive for guaranteeing the stability of the teleopera-

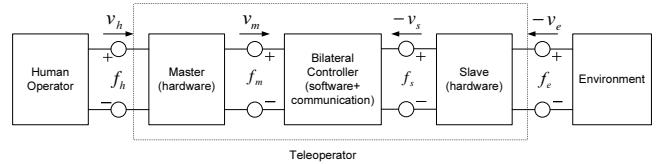

Fig. 3. Block diagram of a complete teleoperation system.

tion system [2], [21]. In the previous work [10], following two-port PO was designed for monitoring the energy flow of the bilateral controller,

$$E_{obsv}(t_k) = \Delta T \sum_{j=0}^k (f_m(t_j)v_m(t_j) + f_s(t_j)v_s(t_j)). \quad (3)$$

and two series PCs are attached at each port of the bilateral controller (Fig. 4) for dissipating active energy flow at each port by adjusting the damping elements α_1 and α_2 . Please see [4], [10], [11], [13] for more detail about the time-domain passivity approach.

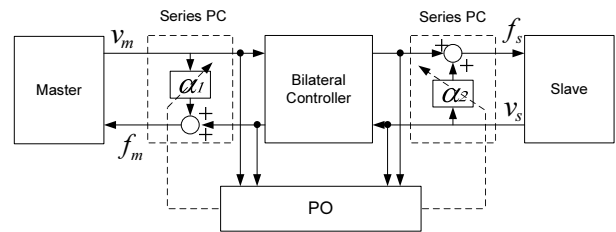

Fig. 4. Block diagram of a teleoperator with PC. Two series PCs are attached at each port of the bilateral controller.

When there was no time-delay, the previous two-port time-domain passivity approach showed satisfiable performance while guaranteeing the passivity [10]. However, once time-delay is introduced, the passivity condition can not be satisfied anymore with the previous approach. The main reason was on the fact that the PO should integrate the power flow at each port of the bilateral controller at the same sampling time.

3. TWO-PORT TIME DOMAIN PASSIVITY APPROACH CONSIDERING TIME-VARYING COMMUNICATION DELAY

In this Section, a modified two-port time-domain passivity approach [14], considering time-varying communication delay, is introduced.

The basic idea of the modified approach is that we can separate the input and output energy at each port based on the sign of the product of the force and velocity at each port.

$$E_{obsv}(k) = E_{in}(k) - E_{out}(k) \quad (4)$$

Note that k means the k ’th step sampling time (t_k).

If the sign of the product at a port is positive, that means energy is flowing into the network system. If the sign is negative, that means energy is flowing out of the network system. (Fig. 5). The total input and output energy of

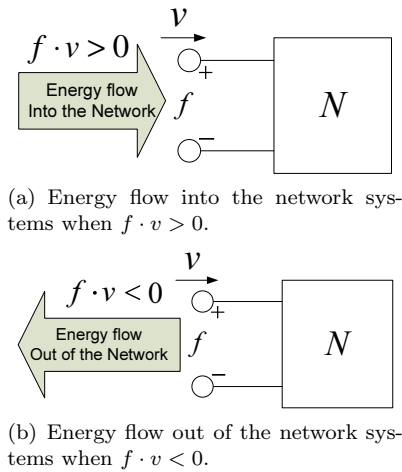

Fig. 5. Based on the sign of the product of force and velocity at a port, it is possible to differentiate whether energy is flowing into the network system or flowing out of the network system

the network system can be calculated by integrating the product for each cases.

$$E_{in}(k) = \begin{cases} E_{in}(k-1) + f(k)v(k) & \text{if } f(k)v(k) > 0 \\ E_{in}(k-1) & \text{if } f(k)v(k) \leq 0 \end{cases} \quad (5)$$

$$E_{out}(k) = \begin{cases} E_{out}(k-1) - f(k)v(k) & \text{if } f(k)v(k) < 0 \\ E_{out}(k-1) & \text{if } f(k)v(k) \geq 0 \end{cases} \quad (6)$$

With the above notation, the time-domain passivity condition for an one-port network (2) can be rewritten as follows:

$$E_{in}(k) \geq E_{out}(k) \quad (7)$$

For the bilateral controller two-port, input and output energy at each port can be calculated in a similar way as (5) and (6).

$$E_{in}^M(k) = \begin{cases} E_{in}^M(k-1) + f_m(k)v_m(k) & \text{if } f_m(k)v_m(k) > 0 \\ E_{in}^M(k-1) & \text{if } f_m(k)v_m(k) \leq 0 \end{cases} \quad (8)$$

$$E_{out}^M(k) = \begin{cases} E_{out}^M(k-1) - f_m(k)v_m(k) & \text{if } f_m(k)v_m(k) < 0 \\ E_{out}^M(k-1) & \text{if } f_m(k)v_m(k) \geq 0 \end{cases} \quad (9)$$

$$E_{in}^S(k) = \begin{cases} E_{in}^S(k-1) - f_s(k)v_s(k) & \text{if } f_s(k)v_s(k) < 0 \\ E_{in}^S(k-1) & \text{if } f_s(k)v_s(k) \geq 0 \end{cases} \quad (10)$$

$$E_{out}^S(k) = \begin{cases} E_{out}^S(k-1) + f_s(k)v_s(k) & \text{if } f_s(k)v_s(k) > 0 \\ E_{out}^S(k-1) & \text{if } f_s(k)v_s(k) \leq 0 \end{cases} \quad (11)$$

With the above notation, the time-domain passivity condition for two-port bilateral controller (3) can be rewritten as follows:

$$E_{in}^M(k) + E_{in}^S(k) \geq E_{out}^M(k) + E_{out}^S(k), \quad \forall k \geq 0 \quad (12)$$

In the previous approach, we adjusted $E_{out}^M(k)$ and $E_{out}^S(k)$ for satisfying the above single condition (12). However, if there is time-delay, the above condition (12) can not be checked in real-time anymore.

In teleoperation system with a bilateral control law, human operator gives energy to the bilateral controller with the master, and this energy is transmitted to the slave

through the bilateral controller. When there is a reflected energy during the interaction between the slave and the environment, this energy is transmitted to the master through the bilateral controller. Based on this causality analysis, we can assume that the main source of the output energy at one port is the input energy at the other port (Fig. 6), and the output energy should be less than the input energy for satisfying the passivity condition. The following sufficient condition of (12) can be derived.

$$E_{in}^M(k) \geq E_{out}^S(k), \quad \forall k \geq 0 \quad (13)$$

$$E_{in}^S(k) \geq E_{out}^M(k), \quad \forall k \geq 0 \quad (14)$$

The output energy at the slave port should be less than the input energy at the master port, and the output energy at the master port should be less than the input energy at the slave port.

This sufficient condition is valid even for the case when there is time-varying communication delay. Assume that D^{MS} and D^{SM} are amount of communication delays from master to slave and slave to master, respectively. The above two conditions can be changed as follows:

$$E_{in}^M(k - D^{MS}) \geq E_{out}^S(k), \quad \forall k \geq 0 \quad (15)$$

$$E_{in}^S(k - D^{SM}) \geq E_{out}^M(k), \quad \forall k \geq 0 \quad (16)$$

The output energy at the slave port should be less than the input energy from the master port with delay, and the output energy at the master port should be less than the input energy from the slave port with delay.

Proof of the passivity with the derived sufficient condition is straightforward. If there is time-varying communication delay, the total energy flow at the two-port bilateral controller is like (17).

$$E_{obsv}(k) = E_{in}^M(k - D^{MS}) - E_{out}^S(k) + E_d^M + E_{in}^S(k - D^{SM}) - E_{out}^M(k) + E_d^S. \quad (17)$$

Where E_d^M and E_d^S are always positive since these are the incremental values of each input energy during the delay.

$$E_d^M = E_{in}^M(k) - E_{in}^M(k - D^{MS}) \geq 0 \quad (18)$$

$$E_d^S = E_{in}^S(k) - E_{in}^S(k - D^{SM}) \geq 0 \quad (19)$$

Therefore, it is sufficient to satisfy (15) and (16) for guaranteeing the passivity of the teleoperator ($E_{obsv}(k) \geq 0$). Note that this proof is valid for the case with time-varying communication delay as well.

This sufficient condition can be satisfied by modifying each output energy $E_{out}^S(k)$ and $E_{out}^M(k)$, which can be accessible in real-time by adding adaptive damping elements at each port (Fig. 7). Two series PCs are attached at each port of the bilateral controller. Two POs at each port are monitoring the input energy and output energy, separately. Input energy from the master (E_{in}^M) is monitored by PO_{in}^M and transmitted to the PO_{out}^S , which monitor the output energy at the slave (E_{out}^S), and adjusting the damping elements α_2 for bounding the output energy at the slave (E_{out}^S). Input energy from the slave (E_{in}^S) is monitored by PO_{in}^S and transmitted to the PO_{out}^M , which monitor the output energy at the master (E_{out}^M), and adjusting the damping elements α_1 for bounding the output energy at the master (E_{out}^M).

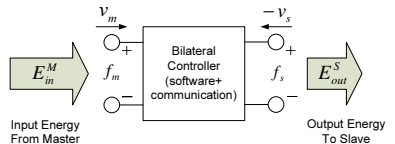

(a) Output energy to the slave should be less than the Input energy from the master for guaranteeing passivity.

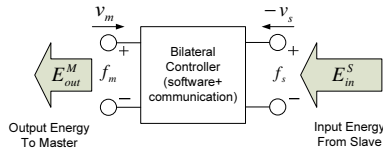

(b) Output energy to the master should be less than the Input energy from the slave for guaranteeing passivity.

Fig. 6. In teleoperation systems with bilateral control law, the main source of the output energy at one port is the input energy at the other port, and the output energy should be less than the input energy.

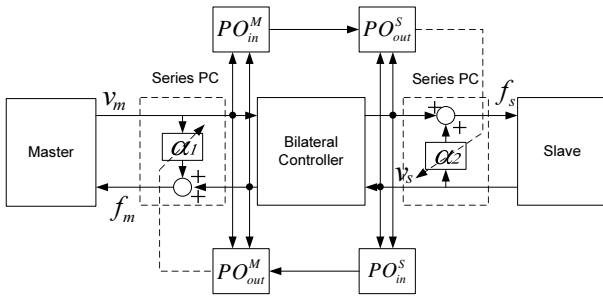

Fig. 7. Block diagram of a teleoperator with newly proposed PO/PC, considering time-delay. Two series PCs are attached at each port of bilateral controller.

4. EXPERIMENTAL RESULTS

Fig. 8 shows the experimental setup for the teleoperation with time delay. PHANToM was used for master and slave manipulator, and UDP connection was used for a data communication. A packet reflector at local site was introduced to make the experimental system experience a time-varying internet delay. The packet reflector has wireless internet connection to the both haptic server and haptic client.

Fig. 9 shows the amount of time-varying delay of the teleoperation system during an experiment. The communication had about 180 (msec) average time-delay for round trip, and varying between 175 (msec) and 275(msec). Since we have used UDP connection for data communication, some data packet might be lost during the communication. Fig. 10 shows the number of lost data packet during a communication experiment. Note that each packet was sent for every single millisecond.

Following position-position bilateral control architecture was used,

$$f_m(t) = K_p(X_s(t - T_D^{SM}) - X_m(t))$$

$$f_s(t) = K_p(X_m(t - T_D^{MS}) - X_s(t))$$

where $K_p = 100(N/m)$ and T_D^{SM} and T_D^{MS} are time-varying communication delay from slave to master and master to slave, respectively.

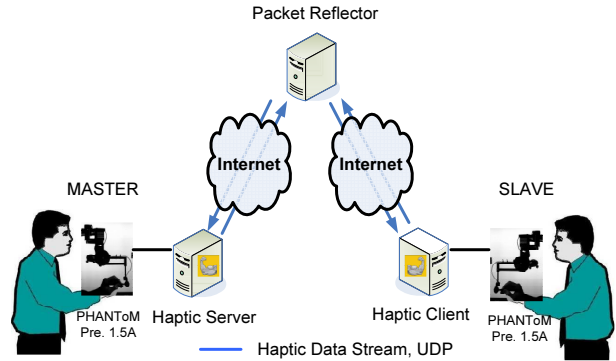

Fig. 8. Experimental setup for the teleoperation with time-delay

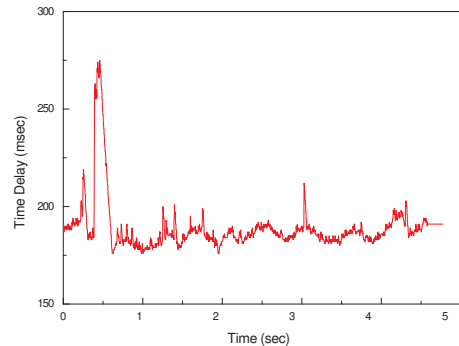

Fig. 9. Amount of time-varying delay of the teleoperation system during an experiment

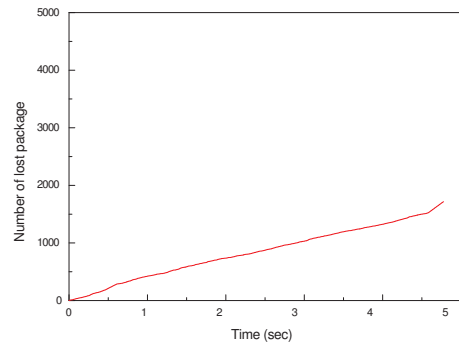
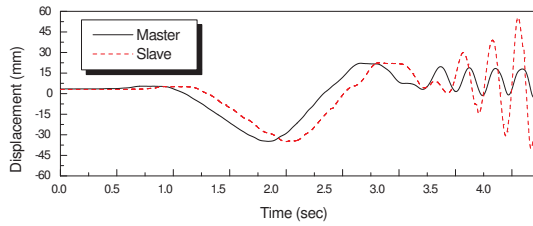

Fig. 10. Number of lost data packet during an experiment

First, operator maneuvered the master manipulator in free space without the PC. Position and force response of the master and slave manipulator showed unstable behavior (Fig. 11(a), 11(b)). Due to the excessive energy output at the master port (Fig. 11(c)), which is greater than the energy input from the slave port, master manipulator was oscillating. Before 3 (sec) slave was seems like following the position command from the master. However the position of the slave manipulator started to diverge since when the output energy at the slave port became greater than the input energy from the master (Fig. 11(d)) (after 3.7 (sec)).

Same experiment as in Fig. 11 has been performed with the proposed PC. Position response of the master and



(a) Position response of the master and slave

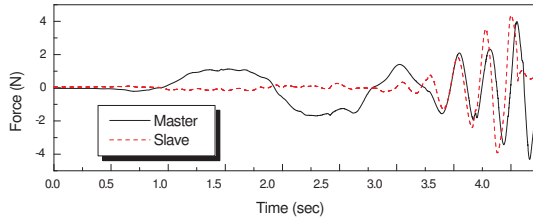

(b) Control force of the master and slave

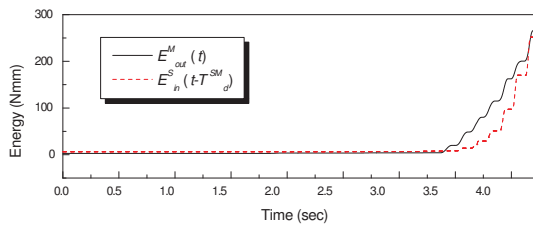

(c) Output energy to the master and input energy from the slave with delay.

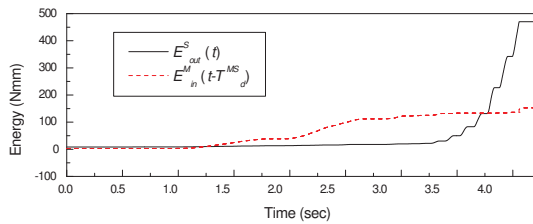

(d) Output energy to the slave and input energy from the slave with delay.

Fig. 11. Free motion with time-varying communication delay and packet loss without PC.

slave manipulator showed stable behavior (Fig. 12(a)). The proposed PC made the bilateral controller passive by making the output energy at the master port stay below the input energy from the slave port (Fig. 12(c)), and the output energy at the slave port stay below the input energy from the master port as well (Fig. 12(d)). When the output energy at the master port was about to be greater than the input energy from the slave port (before 2 (sec) and around 3 (sec) in Fig. 12(c)), the PC was activated and modified the control force of the master when it is necessary (Fig. 12(b)).

We made a hard contact with about the same communication time-delay and with the proposed PC. Position response of the master and slave manipulator was stable (Fig. 13(a)). The proposed PC made the output energy at the master port staying below the input energy from the slave port (Fig. 13(c)). The contact started about 1.7 (sec) and ended about 3.7 (sec). At the end of the contact, the bilateral controller was about to produce active energy at the master port, which is larger than the input energy

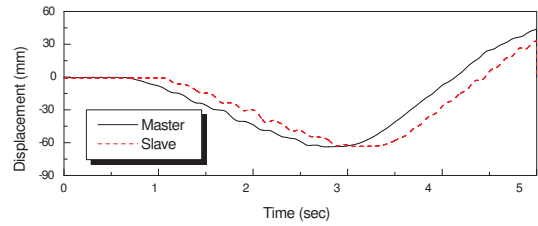

(a) Position response of the master and slave

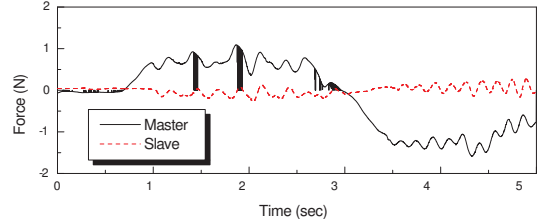

(b) Control force of the master and slave

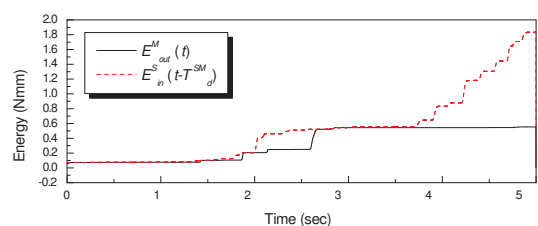

(c) Output energy to the master and input energy from the slave with delay.

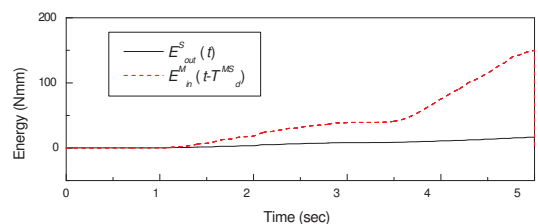

(d) Output energy to the slave and input energy from the slave with delay.

Fig. 12. Free motion with time-varying communication delay and packet loss with PC.

from the slave port. (Fig. 13(c)), so the PC at the master port was activated to dissipate the active energy output (Fig. 13(b)).

5. CONCLUSIONS AND FUTURE WORKS

This paper proved the feasibility of the recently modified two-port time-domain passivity approach under serious time-varying delay and packet loss communication condition. The proposed controller can guarantee the stability even under very serious communication condition, about 180 (msec) average time-delay for round trip, variation range was in between 175 (msec) and 275(msec), and almost one over third of the data packet was lost.

There are still some issues about the performance, such as noisy behavior of the PC. However, the proposed approach has its own contribution on that it can guarantee the passivity of a teleoperator even under serious time-varying communication delay.

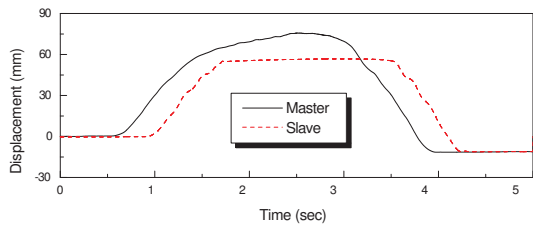

(a) Position response of the master and slave

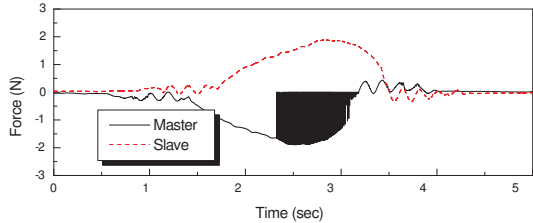

(b) Control force of the master and slave

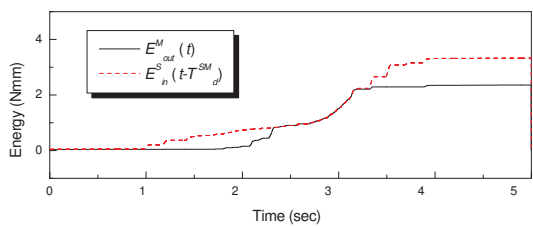

(c) Output energy to the master and input energy from the slave with delay.

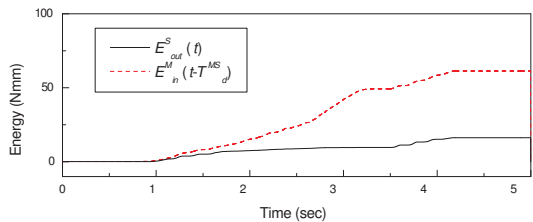

(d) Output energy to the slave and input energy from the slave with delay.

Fig. 13. Hard contact with time-varying communication delay and packet loss with PC.

REFERENCES

[1] R. J. Anderson and M. W. Spong, "Bilateral Control of Teleoperators with Time Delay," *IEEE Trans. on Automatic Control*, Vol. 34, No. 5, pp. 494-501, 1989.

[2] R. J. Anderson and M. W. Spong, "Asymptotic Stability for Force Reflecting Teleoperators with Time Delay," *Int. Journal of Robotics Research*, Vol. 11, No. 2, pp. 135-149, 1992.

[3] K. Goldberg et al., "The Mercury Project: A Feasibility Study for Internet Robots," *IEEE Robotics and Automation Magazine (Special Issue on "Robots on the Web")*, Vol. 7, No. 1, pp. 35-40, 2000.

[4] B. Hannaford and J. H. Ryu, "Time Domain Passivity Control of Haptic Interfaces," *IEEE Trans. on Robotics and Automation*, vol. 18, no. 1, pp. 1-10, 2002.

[5] K. Kosuge et al., "Bilateral Feedback Control of Telemanipulators via Computer Network," *IEEE/RSJ IROS'96*, pp. 1380-1385, 1996.

[6] G. M. H. Leung et al., "Bilateral Controller for Teleoperators with Time Delay via μ -Synthesis,"

IEEE Trans. on Robotics and Automation, Vol. 11, No. 1, pp. 105-116, 1995.

[7] G. Niemeyer and J. J. E. Slotine, "Stable Adaptive Teleoperation," *IEEE J. of Oceanic Engineering*, Vol. 16, No. 1, pp. 152-162, 1991.

[8] G. Niemeyer and J. J. E. Slotine, "Toward Force-Reflecting Teleoperation Over the Internet," *IEEE ICRA '98*, pp. 1909-1915, 1998.

[9] R. Oboe and P. Fiorini, "A Design and Control Environment for Internet-Based Telerobotics," *International Journal of Robotics Research*, Vol. 17, No. 4, pp. 433-449, 1998.

[10] J. H. Ryu, D. S. Kwon and B. Hannaford, "Stable Teleoperation with Time Domain Passivity Control," *IEEE Trans. on Robotics and Automation*, vol. 20, no. 2, pp. 365-373, 2004.

[11] J. H. Ryu, Y. S. Kim and B. Hannaford, "Sampled and Continuous Time Passivity and Stability of Virtual Environments," *IEEE Trans. on Robotics*, vol. 20, no. 4, pp. 772-776, 2004.

[12] J. H. Ryu, B. Hannaford, C. Preusche, and G. Hirzinger "Time Domain Passivity Control with Reference Energy Behavior," *IEEE Trans. on Control Systems Technology*, Vol. 13, No. 5, pp. 737-742, 2005.

[13] J. H. Ryu, D. S. Kwon and B. Hannaford, "Stability Guaranteed Control: Time Domain Passivity Approach," *IEEE Trans. on Control Systems Technology*, Vol. 12, No. 6, pp. 860-868, 2004.

[14] J. H. Ryu, C. Preusche, "Stable Bilateral Control of Teleoperators Under Time-varying Communication Delay: Time Domain Passivity Approach," *will be appear in IEEE ICRA '07*.

[15] A. Santo et al. "Network-Based Toward Force-Reflecting Teleoperation," *IEEE ICRA'2000*, pp. 3126-3131, 2000.

[16] T. B. Sheridan, "Space Teleoperation Through Time Delay: Review and Prognosis," *IEEE Trans. on Robotics and Automation*, Vol. 9, No. 5, pp. 592-606, 1993.

[17] J. Vertut and P. Coiffet, *Robot Technology, Volume 3A: Teleoperations and Robotics: Evolution and Development.*, Prentice Hall, Englewood Cliffs, NJ; 1986.

[18] A. J. van der Schaft, "L2-Gain and Passivity Techniques in Nonlinear Control," Springer, Communications and Control Engineering Series, 2000.

[19] J. C. Willems, "Dissipative Dynamical Systems, Part I: General Theory," *Arch. Rat. Mech. An.*, vol. 45, pp. 321-351, 1972.

[20] Y. Yokokohji et al., "Bilateral Teleoperation under Time-Varying Communication Delay," *IEEE/RSJ IROS'99*, pp. 1854-1859, 1999.

[21] Y. Yokokohji and T. Yoshikawa, "Bilateral Control of Master-slave Manipulators for Ideal Kinesthetic Coupling-Formulation and Experiment," *IEEE Trans. on Robotics and Automation*, Vol. 10, No. 5, pp. 605-620, 1994.