

THEORETICAL AND EXPERIMENTAL RESULTS OF ENERGY BASED SWINGING UP CONTROL FOR A REMOTELY DRIVEN ACROBOT

Xin XIN Masahiro KANEDA Taiga YAMASAKI
Kazuhisa OMASA

*Department of Communication Engineering
Faculty of Computer Science and System Engineering
Okayama Prefectural University
111 Kuboki, Soja, Okayama 719-1197, JAPAN
Email: {xin,kaneda,taiga}@c.oka-pu.ac.jp*

Abstract: The swinging up control for a remotely driven Acrobot (RDA) is studied and an energy based controller is designed via the Lyapunov stability theory. The analysis of convergence of the energy as well as the motion of the RDA under the controller is presented. The conditions on control parameters for achieving a successful swinging up control are given. Furthermore, simulation and experimental results are provided to validate the presented theoretical results. *Copyright © 2005 IFAC*

Keywords: the Acrobot, Underactuated mechanical system, Swinging up control, Robot control, Stability, Lyapunov methods, Energy control, Attractor.

1. INTRODUCTION

Underactuated mechanical systems, which have less number of actuators than that of generalized coordinates, have been eagerly studied for more than a decade from the perspectives of lightening weight, increasing reliability and saving energy. However, controlling those systems is very challenging due to inherently complex nonlinear dynamics and nonholonomic behavior, see e.g., (Kolmanovsky and McClamroch, 1995; Spong, 1995).

The Acrobot, which is a 2-link planar robot with the first link being attached to a passive joint, has been studied as a typical example of underactuated mechanical systems, see e.g., (Spong, 1995; Brown and Passino, 1997; Berke-meier and Fearing, 1999; Zergeroglu *et al.*, 1999). There are two types of the Acrobot: one is the directly driven acrobot (DDA) (Hauser and Murray, 1990; Spong, 1995) for which the second joint is directly driven, and the other is the remotely

driven acrobot (RDA) (Bortoff, 1994; Zergeroglu *et al.*, 1999; Fujiwara *et al.*, 2003) for which the second joint is remotely (indirectly) driven, e.g., through a belt. Indeed, the control torque is applied to the relative angle between two links for the DDA, while to the absolute angle of the second link to the horizontal for the RDA in (Fujiwara *et al.*, 2003).

Many research efforts have been made to investigate the energy based control approach to controlling underactuated mechanical systems, e.g., for the swinging up control of the cart-pole system (Åström and Furuta, 2000), the Pendubot (Fantoni *et al.*, 2000; Kolesnichenko and Shiriaev, 2002), the DDA (Xin and Kaneda, 2002), etc. To best our knowledge, the application of such approach to the swinging up control of the RDA has not been reported yet.

Due to different configurations of the DDA and the RDA, their control designs have been primarily studied separately (Hauser and Murray, 1990;

Bortoff, 1994). A control strategy to regulate the first link at any desired position, which is applicable to both the DDA and the RDA, was proposed in (Zergeroglu *et al.*, 1999); however, such strategy can not stabilize the upright equilibrium point of the robot, thus it is not appropriate for the swinging up control.

The swinging up control problem for the RDA in (Fujiwara *et al.*, 2003) studied in this paper is: to design a controller under which the RDA can be swung up from any initial state to an arbitrarily small neighborhood of the upright equilibrium point. This guarantees that the balancing control of the RDA about the vertical can then be easily accomplished.

Based on the Lyapunov stability theory, an energy based swinging up controller is proposed. The analysis of convergence of the energy as well as the motion of the RDA under the controller is presented. The conditions on control parameters for achieving a successful swinging up control are given. Furthermore, simulation and experimental results obtained not only validate the presented theoretical results, but also show the fast convergence of the closed-loop solution to a desired homoclinic orbit.

2. DYNAMIC MODELS OF 2-LINK UNDERACTUATED ROBOTS

Consider a 2-link underactuated robot shown in Fig. 1. Its motion equation is described as follows:

$$M(q)\ddot{q} + C(q, \dot{q})\dot{q} + G(q) = B\tau \quad (1)$$

where $q = [q_1 \ q_2]^T$, scalar τ is control input, and

$$M(q) = \begin{bmatrix} c_1 + c_2 + 2c_3 \cos q_2 & c_2 + c_3 \cos q_2 \\ c_2 + c_3 \cos q_2 & c_2 \end{bmatrix} \quad (2)$$

$$C(q, \dot{q}) = c_3 \sin(q_2) \begin{bmatrix} -\dot{q}_2 & -\dot{q}_1 - \dot{q}_2 \\ \dot{q}_1 & 0 \end{bmatrix} \quad (3)$$

$$G(q) = \begin{bmatrix} c_4 g \cos q_1 + c_5 g \cos(q_1 + q_2) \\ c_5 g \cos(q_1 + q_2) \end{bmatrix} \quad (4)$$

$$B = [b_1 \ b_2]^T \quad (5)$$

and c_1, \dots, c_5 are

$$\begin{cases} c_1 = m_1 l_{c1}^2 + m_2 l_1^2 + I_1, & c_2 = m_2 l_{c2}^2 + I_2, \\ c_3 = m_2 l_1 l_{c2}, & c_4 = m_1 l_{c1} + m_2 l_1, & c_5 = m_2 l_{c2} \end{cases}$$

Note that the control input transformation matrix B is different for the following underactuated robots:

1). For the Pendubot (Spong and Block, 1995) where only joint 1 is actuated, $B = [1 \ 0]^T$;

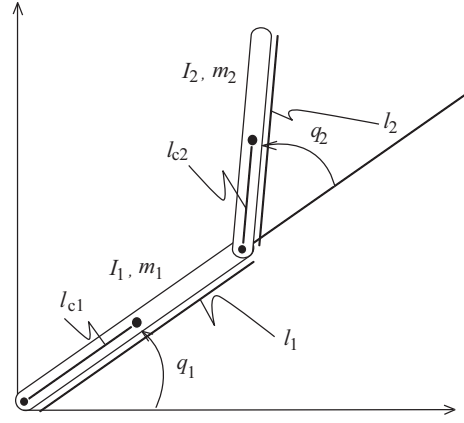

Fig. 1. 2-link underactuated robot

2). For the DDA shown in (Hauser and Murray, 1990; Spong, 1995) where the relative angle between two links, i.e., q_2 is actuated,

$$B = [0 \ 1]^T, \text{ for the DDA} \quad (6)$$

3). For the remotely driven Acrobot in (Fujiwara *et al.*, 2003) where the absolute angle of the link 2 is actuated via timing belt,

$$B = [1 \ 1]^T, \text{ for the RDA} \quad (7)$$

For the RDA (Fujiwara *et al.*, 2003) considered hereafter, the following transformation

$$\theta_1 = q_1 - \frac{\pi}{2}, \quad \theta_2 = q_1 + q_2 - \frac{\pi}{2} \quad (8)$$

reduces (1) with B given in (7) to

$$M_\theta(\theta)\ddot{\theta} + C_\theta(\theta, \dot{\theta})\dot{\theta} + G_\theta(\theta) = \begin{bmatrix} 0 \\ 1 \end{bmatrix} \tau \quad (9)$$

where $\theta = [\theta_1 \ \theta_2]^T$,

$$M_\theta(\theta) = \begin{bmatrix} c_1 & c_3 \cos(\theta_2 - \theta_1) \\ c_3 \cos(\theta_2 - \theta_1) & c_2 \end{bmatrix} \quad (10)$$

$$C_\theta(\theta, \dot{\theta}) = c_3 \sin(\theta_2 - \theta_1) \begin{bmatrix} 0 & -\dot{\theta}_2 \\ \dot{\theta}_1 & 0 \end{bmatrix} \quad (11)$$

$$G_\theta(\theta) = \begin{bmatrix} -c_4 g \sin \theta_1 \\ -c_5 g \sin \theta_2 \end{bmatrix} \quad (12)$$

Moreover, the upright equilibrium point of the RDA is expressed as $(\theta_1, \theta_2, \dot{\theta}_1, \dot{\theta}_2) = (0, 0, 0, 0)$.

Note that under the generalized coordinates q and θ for the DDA and the RDA in (9), respectively, though the control input transformation matrix is same, the corresponding structure of coefficient matrices is different.

3. THE ENERGY BASED SWINGING UP CONTROLLER

Note that the control objective is to find a controller under which the RDA can be swung up from any initial state to an arbitrarily small neighborhood of the upright equilibrium point.

To this end, by setting the potential energy of the RDA at the upright equilibrium point to be 0, the total energy of the RDA is given by

$$E = \frac{1}{2}\dot{\theta}^T M_\theta(\theta)\dot{\theta} + c_4g(\cos\theta_1 - 1) + c_5g(\cos\theta_2 - 1) \quad (13)$$

In what follows, the primary goal is to design a controller such that

$$\lim_{t \rightarrow \infty} \theta_2 = 0, \quad \lim_{t \rightarrow \infty} E = E_r \quad (14)$$

where constant E_r is a given reference of E and satisfying

$$E_r \geq \min E = -2(c_4 + c_5)g \quad (15)$$

This paper will show that theoretically it suffices to choose $E_r = 0$ for attaining the formentioned swinging up control objective. Nevertheless, practically, nonzero E_r is expected to increase the robustness of the proposed control strategy against modeling errors.

Define

$$\begin{aligned} \Delta &= c_1c_2 - c_3^2\cos^2(\theta_2 - \theta_1) \\ \Xi &= -c_1c_3\dot{\theta}_1^2\sin(\theta_2 - \theta_1) - \frac{1}{2}c_3^2\dot{\theta}_2^2\sin 2(\theta_2 - \theta_1) \\ &\quad - c_3c_4g\sin(\theta_1)\cos(\theta_2 - \theta_1) + c_1c_5g\sin\theta_2 \end{aligned}$$

The following theorem is obtained.

THEOREM 1. Consider the RDA described in (9). Let constant E_r satisfying (15) be a reference of E . Suppose constant control parameters k_D , k_P , k_V satisfy

$$k_D > c_2(2(c_4 + c_5)g + E_r) \quad (16)$$

$k_P > 0$ and $k_V > 0$, respectively, then the following controller

$$\tau = -\frac{(k_V\dot{\theta}_2 + k_P\theta_2)\Delta + k_D\Xi}{(E - E_r)\Delta + c_1k_D} \quad (17)$$

contains no singular points, and yields

$$\lim_{t \rightarrow \infty} \theta_2 = \theta_2^*, \quad \lim_{t \rightarrow \infty} E = E^* \quad (18)$$

where θ_2^* , E^* are constants.

Proof. Consider the following Lyapunov function candidate.

$$V = \frac{1}{2}(E - E_r)^2 + \frac{1}{2}k_D\dot{\theta}_2^2 + \frac{1}{2}k_P\theta_2^2 \quad (19)$$

Taking the time derivative of V along (9), together with the property $\dot{E} = \theta_2\tau$, yields

$$\dot{V} = \dot{\theta}_2[(E - E_r)\tau + k_D\ddot{\theta}_2 + k_P\theta_2]$$

If τ can be chosen such that

$$(E - E_r)\tau + k_D\ddot{\theta}_2 + k_P\theta_2 = -k_V\dot{\theta}_2 \quad (20)$$

then

$$\dot{V} = -k_V\dot{\theta}_2^2 \leq 0, \quad \text{for } k_V > 0 \quad (21)$$

In what follows, whether (20) is solvable with respect to τ is discussed. To this end, putting $\ddot{\theta}_2 = (c_1\tau + \Xi)/\Delta$, which is obtained from (9), gives

$$\begin{aligned} &(E - E_r + k_Dc_1/\Delta)\tau \\ &= -k_V\dot{\theta}_2 - k_P\theta_2 - k_D\Xi/\Delta \end{aligned} \quad (22)$$

Using $E \geq -2(c_4 + c_5)g$ and $c_1/\Delta \geq 1/c_2$ shows $E - E_r + k_Dc_1/\Delta \geq -2(c_4 + c_5)g - E_r + k_D/c_2$. This proves inequality $E - E_r + k_Dc_1/\Delta > 0$ under the condition (16). Moreover, the controller (17) can be obtained from (22) directly.

Finally, owing to (21), $\dot{V}(t) = 0$ and $\dot{\theta}_2(t) = 0$ will hold as $t \rightarrow \infty$. Therefore, V and θ_2 will converge to some constants. This together with Lyapunov function in (19) yields that E will converge to a constant. This completes the proof of Theorem 1. ■

4. THE CONVERGENCE OF THE ENERGY AND THE MOTION OF THE RDA

The convergent values E^* and θ_2^* are discussed and the motion of the RDA under the controller (17) is analyzed in this section.

First, the following theorem is attained.

THEOREM 2. With the quantities described in Theorem 1, if $E^* \neq E_r$, then the closed-loop solution of the RDA converges to an equilibrium point $(\theta_1, \theta_2, \dot{\theta}_1, \dot{\theta}_2) = (\theta_1^*, \theta_2^*, 0, 0)$ satisfying

$$\theta_1^* = 0, \quad \text{or,} \quad -\pi \pmod{2\pi} \quad (23)$$

$$k_P\theta_2^* - (E^* - E_r)c_5g\sin\theta_2^* = 0 \quad (24)$$

Proof. If $E^* \neq E_r$, then it follows from (20) with $\theta_2 = \theta_2^*$ and $E = E^*$ that

$$k_P\theta_2^* + (E^* - E_r)\tau = 0 \quad (25)$$

This shows that τ is constant denoted as τ^* in what follows. It follows from (9) that τ^* satisfies

$$\begin{aligned} c_3 \ddot{\theta}_1 \cos(\theta_2^* - \theta_1) + c_3 \dot{\theta}_1^2 \sin(\theta_2^* - \theta_1) \\ = \tau^* + c_5 g \sin \theta_2^* \end{aligned}$$

Integrating it with respect to time t yields

$$c_3 \dot{\theta}_1 \cos(\theta_2^* - \theta_1) = (\tau^* + c_5 g \sin \theta_2^*)t + \alpha_1 \quad (26)$$

where α_1 is constant.

Note that Lyapunov function V is bounded due to semi-definite positive of \dot{V} in (21). Thus, the energy E is bounded, so is $\dot{\theta}_1$. Therefore, since (26) holds for all t , then the relation

$$\tau^* = -c_5 g \sin \theta_2^*$$

must hold, otherwise there is a contradiction that the left side term of (26) is bounded while the right side term is unbounded as $t \rightarrow \infty$. Consequently,

$$c_3 \dot{\theta}_1 \cos(\theta_2^* - \theta_1) = \alpha_1$$

holds. Integrating the above equation with respect to time t yields

$$c_3 \sin(\theta_1 - \theta_2^*) = \alpha_1 t + \alpha_2$$

where α_2 is constant. Since this equation holds for all t , then $\alpha_1 = 0$. Thus, $c_3 \sin(\theta_1 - \theta_2^*) = \alpha_2$. This shows that θ_1 is a constant noted as θ_1^* . Again from the dynamic model of the RDA in (9), one obtains $-c_4 g \sin \theta_1^* = 0$. This shows (23). Finally, putting $\tau = \tau^*$ into (25) gives (24). ■

Next, define

$$\eta(\theta_1^*, \theta_2^*) = \frac{[c_4 g(\cos \theta_1^* - 1) + c_5 g(\cos \theta_2^* - 1) - E_r] \sin \theta_2^*}{\theta_2^*} \quad (27)$$

The following theorem is provided.

THEOREM 3. In addition to the quantities described in Theorem 1, if $E_r \geq 0$ and control parameter k_P satisfies

$$k_P > c_5 g \eta^* \quad (28)$$

where

$$\eta^* = \max\{\eta(-\pi, \theta_2^*) : \theta_2^* \in [\pi, 2\pi]\} > 0 \quad (29)$$

then under the energy based controller (17), for any initial condition of the RDA, either of the following two statements holds:

i) $E^* = E_r$ holds, and the closed-loop solution of the RDA converges to

$$\dot{\theta}_1^2 = \frac{2c_4 g}{c_1} (1 - \cos \theta_1) + \frac{2E_r}{c_1} \quad (30)$$

$$(\theta_2, \dot{\theta}_2) = (0, 0) \quad (31)$$

ii) $E^* \neq E_r$ holds, and the closed-loop solution of the RDA converges either to the upright equilibrium $(\theta_1, \theta_2, \dot{\theta}_1, \dot{\theta}_2) = (0, 0, 0, 0)$ or to the down-up (link 1 is down and link 2 is up) equilibrium point $(\theta_1, \theta_2, \dot{\theta}_1, \dot{\theta}_2) = (-\pi, 0, 0, 0)$. Moreover, such down-up equilibrium point is unstable.

Proof. *i)* If $E^* = E_r$, it follows from (24) that $\theta_2^* = 0$ holds. Thus, (30) is obtained by using formula of energy E in (13).

ii) If $E^* \neq E_r$, Theorem 2 shows that the closed-loop solution converges to an equilibrium point satisfying (23) and (24). Under the condition (28), such equilibrium point is to be either the upright or the down-up equilibrium point. To show this, putting $E^* = c_4 g(\cos \theta_1^* - 1) + c_5 g(\cos \theta_2^* - 1)$ into (24) gives

$$\begin{aligned} k_P \theta_2^* - c_5 g [c_4 g(\cos \theta_1^* - 1) \\ + c_5 g(\cos \theta_2^* - 1) - E_r] \sin \theta_2^* = 0 \quad (32) \end{aligned}$$

Obviously $\theta_2^* = 0$ is a solution of the above equation; it suffices to show the unique solution under the condition (28). To show this, rewrite (32) with $\eta(\theta_1^*, \theta_2^*)$ in (27) as

$$\theta_2^* [k_P - c_5 g \eta(\theta_1^*, \theta_2^*)] = 0 \quad (33)$$

Therefore, $\theta_2^* = 0$ is the unique solution of (33) if and only if

$$k_P > c_5 g \sup_{\theta_1^* \in \{0, -\pi\}, \theta_2^* \neq 0} \eta(\theta_1^*, \theta_2^*)$$

Since $\eta(\theta_1^*, \theta_2^*)$ is an even function with respect to θ_2^* , and $c_4 g(\cos \theta_1^* - 1) + c_5 g(\cos \theta_2^* - 1) - E_r \leq 0$ for $E_r \geq 0$, therefore,

$$\begin{aligned} 0 < \sup_{\theta_1^* \in \{0, -\pi\}, \theta_2^* \neq 0} \eta(\theta_1^*, \theta_2^*) \\ = \sup_{\theta_1^* \in \{0, \pi\}, \theta_2^* \in [2(n-1)\pi, (2n-1)\pi]} \eta(\theta_1^*, \theta_2^*) \end{aligned}$$

which is a strictly decreasing function of positive integer n . Consequently,

$$\sup_{\theta_1^* \in \{0, -\pi\}, \theta_2^* \neq 0} \eta(\theta_1^*, \theta_2^*) = \eta^* > 0$$

Therefore, under (28), $\theta_2^* = 0$ is the unique solution of (33).

To complete the proof of the statement *ii)*, it suffices to show that the down-up equilibrium point (DUEP) is unstable. Consider an initial state $(\theta_1, \theta_2, \dot{\theta}_1, \dot{\theta}_2) = (-\pi + \epsilon_1, 0, \epsilon_2, 0)$ near the DUEP. Denoted its energy as E_ϵ . From (13),

$$E_\epsilon = c_1 \epsilon_2^2 / 2 - c_4 g (\cos \epsilon_1 + 1) > -2c_4 g$$

Since there exists $\epsilon > 0$ such that $E_\epsilon - E_r < 0$ holds for any (ϵ_1, ϵ_2) satisfying $0 < \epsilon_1^2 + \epsilon_2^2 < \epsilon^2$, then there exist ϵ_1, ϵ_2 such that

$$V(-\pi + \epsilon_1, 0, \epsilon_2, 0) < V(-\pi, 0, 0, 0)$$

no matter how small ϵ is. Since V is non-increasing under the control law (17), therefore, starting from $(\theta_1, \theta_2, \dot{\theta}_1, \dot{\theta}_2) = (-\pi + \epsilon_1, 0, \epsilon_2, 0)$, the closed-loop solution will not converge to the DUEP. This shows that the DUEP is unstable. ■

Finally, consider the case $E_r = 0$. The following results follow directly from Theorem 3.

COROLLARY 1. With the quantities described in Theorem 3 if $E_r = 0$, then under the energy based controller (17), for any initial condition of the RDA, either of the following statements holds:

i) $E^* = 0$ holds, and the closed-loop solution of the RDA converges to

$$\begin{aligned} \dot{\theta}_1^2 &= \frac{2c_4 g}{c_1} (1 - \cos \theta_1) \\ (\theta_2, \dot{\theta}_2) &= (0, 0) \end{aligned} \quad (34)$$

ii) $E^* \neq 0$ holds, and the closed-loop solution of the RDA converges to the down-up equilibrium point. Moreover, the down-up equilibrium point is unstable.

REMARK 1. (34) is a homoclinic orbit with

$$\theta_1 = 0 \pmod{2\pi}, \quad \dot{\theta}_1 = 0$$

being its equilibrium point. Since the RDA can not be maintained at the DUEP in practice, according to the statement i) of Corollary 1, starting from *any initial state*, the closed-loop solution will converge to the homoclinic orbit; this shows that the RDA will eventually be swung up to an arbitrarily small neighborhood of the upright equilibrium point. The locally stabilizing controller can be switched on once the RDA enters to a prescribed small neighborhood of the upright equilibrium point.

REMARK 2. If $E_r = 0$, owing to definition of η^* defined in (29), inequality $\eta^* < 2(c_4 + c_5)g/\pi$ holds. Therefore, inequality (28) on k_P can be replaced by a simplified condition

$$k_P \geq 2(c_4 + c_5)c_5 g^2 / \pi \quad (35)$$

5. SIMULATION AND EXPERIMENTAL RESULTS

The validity of the developed theoretical results is verified via simulation and experimental inves-

tigation to the RDA described in (Fujiwara *et al.*, 2003).

For the RDA, $c_1 = 0.1467$, $c_2 = 0.1131$, $c_3 = 0.0904$, $c_4 = 0.3950$, $c_5 = 0.3160$ and the main mechanical parameters of the RDA are described in Table 1.

Table 1. Main Parameters of the RDA

m_1	0.72[kg]	m_2	1.29[kg]
l_1	0.30[m]	l_2	0.50[m]

Here $g = 9.8[\text{m/s}^2]$ is taken. The initial condition of the RDA is $\theta_1(0) = \theta_2(0) = -\pi$, $\dot{\theta}_1(0) = \dot{\theta}_2(0) = 0$. This means that the RDA is in the downward position.

Take $E_r = 0$. According to (16) and (28), the conditions on k_D and k_P become $k_D > 1.57$ and $k_P > 7.97$. The following control parameters are chosen: $k_D = 1.8$, $k_P = 9.7$, $k_V = 6.0$.

The simulation results under controller (17) with the above control parameters are depicted in Figs. 2, 3. It is shown from Fig. 2 that θ_2 converges to 0, and link 1 is swung up quickly close to the vertical. It follow from Fig. 3 that E converges to zero, and $(\theta_1, \dot{\theta}_1)$ converges to homoclinic orbit (34).

The experiment of the swinging up control for the RDA has been carried out. The experimental results match the simulation ones in some degree, see Fig. 4; the RDA has been shown to swung up quickly and close to the vertical position. Some difference between the simulation and experimental results may be caused by modelling error such as unmodelled dynamics of friction term and uncertainty of mechanical parameters.

As to the role of energy reference E_r , the following observation has been obtained. Simulation results show that appropriate nonzero E_r can lessen the effect of unmodelled friction to the swinging up control objective; indeed, in contrast to $E_r = 0$, the RDA can be swung up closer to the upright equilibrium point for appropriate nonzero E_r . The experiment results exhibit that a swinging pattern of the RDA occurred for zero E_r can be changed to a rotational pattern for a positive E_r . The further numerical and experimental investigation is being carried out.

6. CONCLUSIONS

The energy based controller for the swinging up the remotely driven Acrobot (RDA) has been provided and the analysis of the convergence of the energy and the motion of the robot have been completed. The conditions on the control parameters for achieving a successful swinging up for the RDA have been provided. Moreover, this

paper has not only proved theoretically that the energy based control is effective for swinging up the RDA, but also shown through the simulation and experimental results that a quick swinging up can be achieved.

7. REFERENCES

- Åström, K.J. and K. Furuta (2000). Swinging up a pendulum by energy control. *Automatica* **36**, 287–295.
- Berkemeier, M.D. and R.S. Fearing (1999). Tracking fast inverted trajectories of the underactuated acrobot. *IEEE Transactions on Robotics and Automation* **15**, 740–750.
- Bortoff, S. A. (1994). Advanced nonlinear robotic control using digital signal processing. *IEEE Transactions on Industrial Electronics* **41**, 32–39.
- Brown, S.C. and K.M. Passino (1997). Intelligent control for an acrobot. *Journal of Intelligent & Robotic Systems* **18**, 209–248.
- Fantoni, I., R. Lozano and M.W. Spong (2000). Energy based control of the pendubot. *IEEE Transactions on Automatic Control* **45**, 725–729.
- Fujiwara, M., X. Xin, T. Yamasaki and M. Kaneda (2003). Mechanical design and controller interface of an acrobat robot. *Proceedings of the 46th Japan Joint Automatic Control Conference* pp. 1060–1062 (In Japanese).
- Hauser, J. and R. M. Murray (1990). Nonlinear controllers for non-integrable systems: the acrobot example. *Proceedings of American Control Conference* pp. 669–670.
- Kolesnichenko, O. and A. S. Shiriaev (2002). Partial stabilization of underactuated euler-lagrange systems via a class of feedback transformations. *Systems & Control Letters* **45**, 121–132.
- Kolmanovsky, I. and N.H. McClamroch (1995). Developments in nonholonomic control problems. *IEEE Control Systems Magazine* **15**, 20–36.
- Spong, M. W. (1995). The swing up control problem for the acrobot. *IEEE Control Systems Magazine* **15**, 49–55.
- Spong, M. W. and D.J. Block (1995). The pendubot: A mechatronic system for control research and education. *Proceedings of the 34th IEEE Conference on Decision and Control*, pp. 555–556.
- Xin, X. and M. Kaneda (2002). The swing up control for the acrobot based on energy control approach. *Proceedings of the 41st IEEE Conference on Decision and Control* pp. 3261–3266.
- Zergeroglu, E., W.E. Dixon, D.M. Dawson and A. Behal (1999). Lyapunov-based set point

control of the acrobot. *International Journal of Robotics & Automation* **14**, 161–170.

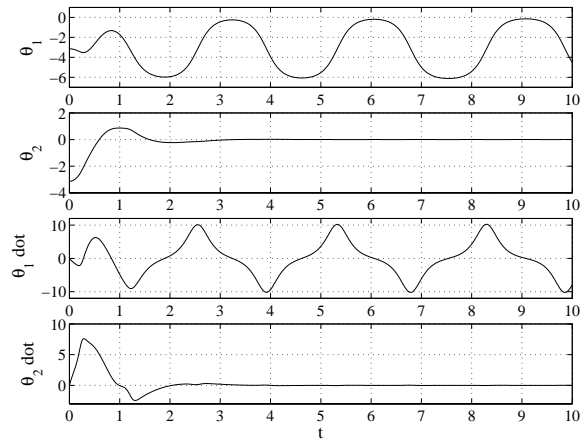

Fig. 2. Time responses of states of the RDA: Simulation results

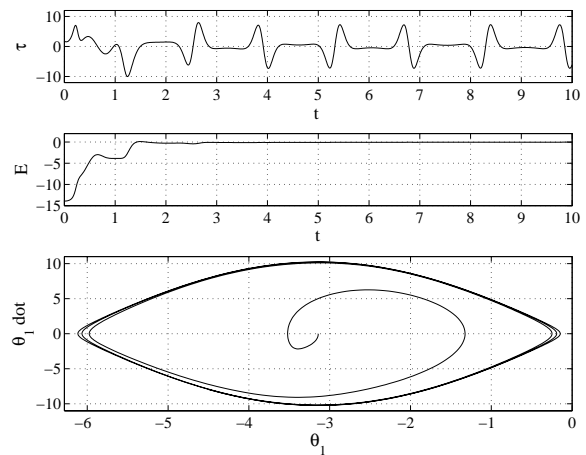

Fig. 3. Time responses of τ , E and phase plot of $(\theta_1, \dot{\theta}_1)$: Simulation results

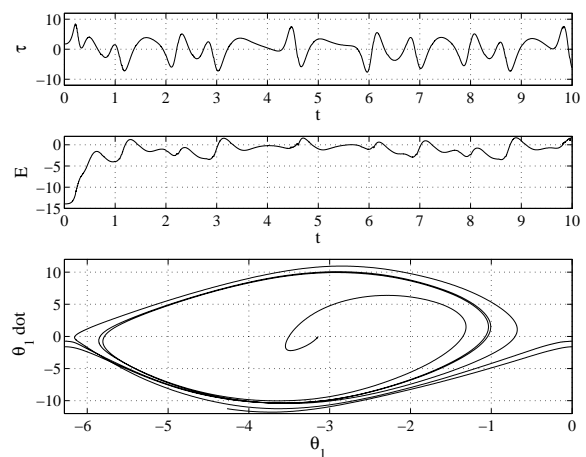

Fig. 4. Time responses of τ , E and phase plot of $(\theta_1, \dot{\theta}_1)$: Experimental results