

## INTEGRATING DISPARATE ANALYTICAL INSTRUMENTATION INTO AN AUTOMATED PROCESS CONTROL SYSTEM USED IN CELL CULTURE PROCESS DEVELOPMENT

**K. Joeris<sup>1</sup>, A. Johnson<sup>2</sup>, M. Brosnan<sup>2</sup>, C. Cruz<sup>1</sup>, C. Zhang<sup>1</sup>, M. Burnett<sup>1</sup>,  
K. Konstantinov<sup>1</sup>**

<sup>1</sup> *Bayer Healthcare, Process Sciences, 800 Dwight Way, Berkeley, CA 94710,  
USA*

<sup>2</sup> *Jova Solutions, 965 Mission Street Suite 600, San Francisco, CA 94103, USA*

**Abstract:** This case study of a cell culture process development lab shows how various common analytical instruments were quickly and effectively integrated into a comprehensive process control and data management system. Streaming time-stamped results from these instruments directly into the process control system enabled automated real-time feedback and advanced characterizations of cell viability, instead of being limited to off-line, post-run analysis. Under the FermWorks process control and data management software, drivers for instruments such as Cedex Cell Analyzer, YSI 2700 Biochemistry Analyzer, Bayer Blood Gas Analyzer and several other custom-made analytical instruments were easily added to the existing network of bioreactors and their hardware controllers (DCUs). *Copyright © 2007 IFAC*

**Keywords:** Automatic Process Control, Biomedical Control, Fermentation processes, Biotechnology, Sensor systems, Sensor integration

### 1. INTRODUCTION

Mammalian cells are being widely used for the production of therapeutic proteins given their ability to correctly fold and glycosylate these proteins.

However, productivities from a typical mammalian cell reactor are low and one approach to increase productivity is using perfusion systems for high cell density cell cultivations. Perfusion bioreactors are characterized by a high degree of automation and require advanced and robust process control for optimal operation. As they are cultivated over long time periods, typically 100 days or more, they require frequent supervision and sampling thereby presenting an ideal case for complete process automation. This would minimize operational variability and ensure stable operation over extended periods of time.

Many inefficiencies in the cell culture or fermentation process result from the use of manual methods of process control and data management, particularly in R&D, process development labs, and pilot plants. The products produced by pharmaceutical companies are becoming increasingly complex, magnifying these inefficiencies. The current “state of the art” in fermentation and cell culture labs is often a loose collection of instruments and measurements, brought together by clipboards and data entered by hand into spreadsheet applications.

Manual methods of data entry have been used for years, and for good reasons. They are tried and true, and many businesses depend on established, trusted procedures rather than risk introducing change. On the other hand, many lab directors, researchers, and technicians would welcome automation, but manual process control and data collection is often seen as

### 2. GENERAL BACKGROUND OF INDUSTRY PRACTICE

the only alternative available, given the existing equipment.

Most comprehensive automation systems are large-scale, expensive systems that require special hardware (such as PLCs) and fully custom software. These systems are often just not practical in the process development lab or pilot plant, where automation rightfully takes a back seat to experimentation, innovation and cost-savings.

In many ways, this status quo of manual process control and data management is dictated by the instrumentation. Instrument manufacturers focus on excellence in function, accuracy, and speed of their devices. They are often less concerned with acting as part of a larger whole, sharing and communicating with other instruments in “the big picture.” The result is islands of data: isolated measurements and analyses, and isolated subsystems like scattered puzzle pieces. Also, instrument manufacturers have specific expertise, and concentrate more on perfecting their own island, and less on building bridges. Lastly, a particular instrument could be a piece in many different puzzles, serving a variety of larger processes. It is a challenge to be a team player in those many different systems.

On the bright side, almost all modern instruments are designed with the *capability* to communicate and cooperate, to make the puzzle pieces fit together. What is lacking is the orchestra conductor who manages and controls all the individual instruments as a unified whole. This must be done by software that works at the *process* level, bridging gaps between disparate subsystems. It was in this context that Bayer adopted the software application described below, and initiated the effort to automate transfer of data from analytical instrumentation into a networked historical database.

### 3. ANALYTICAL INSTRUMENTS

The process development laboratory utilizes several instruments to characterize samples taken from active cell culture perfusion processes. These instruments include the Cedex Cell Analyzer (Innovatis, Bielefeld, Germany), the 2700 Biochemistry Analyzer (YSI, Yellow Springs, USA), and the Rapidlab 248 Blood Gas Analyzer (BGA) (Bayer Healthcare, USA). Samples are brought to the instruments throughout the day, from all of the many bioreactors running at any given time. In addition, several in-process systems for real-time analysis, like the In-situ microscope (Sartorius AG, Goettingen, Germany) as well as sensors for offgas O<sub>2</sub> and CO<sub>2</sub> analysis (Bluesens GbR, Herten, Germany) are used for process monitoring and control.

### 4. NEED TO INTEGRATE OFFLINE ANALYTICAL DATA INTO PROCESS CONTROL ALGORITHMS

Prior to the implementation of the networked supervisory control and data acquisition (SCADA) system, analytic data from samples (e.g. pH, DO, cell density, glucose, glutamine, etc.) were entered in a spreadsheet application. There, these data were further combined with values taken directly from bioreactor controllers (different types of DCUs, Sartorius AG, Germany) to determine new setpoints for process control elements such as cell discard and harvest rate.

The time between sampler analysis and change to setpoint could be quite long, depending on when the sample was processed and when the new setpoint was determined. Shortening this time lag was a key motivation in adopting a process automation software tool.

### 5. FERMWORKS DESCRIPTION

FermWorks (JoVa Solutions, San Francisco, USA) is the SCADA system that was introduced in the process development laboratories to monitor the bioreactor control equipment in use, such as DCUs, in-situ probes, peristaltic pumps, and other equipment controlled via analog signals.

FermWorks is a networked and distributed application with local storage of historical data and a central SQL database holding configuration and parametric data. Each FermWorks computer on the network can communicate with one or several bioreactor controllers, and can log data from as many bioreactors as are connected to the controllers. Process control algorithms which execute at a FermWorks computer can share data in real time with other FermWorks computers, thus allowing distribution of data and control, including off-site monitoring.

### 6. SUPPORT FOR OFFLINE DATA ENTRY AND NEW DEVICES VIA PLUG-INS

The software also allows new functionality to be simply integrated through a plug-in mechanism, referred to as the Interface Layer in Figure 1. New code, written in the LabVIEW language (National Instruments, Austin, USA), is instantiated in the software without stopping or recompiling the main application, the FermWorks Core (Fig.1). This is a critical feature when perfusion experiments last several months and opportunities for a complete system shutdown are rare.

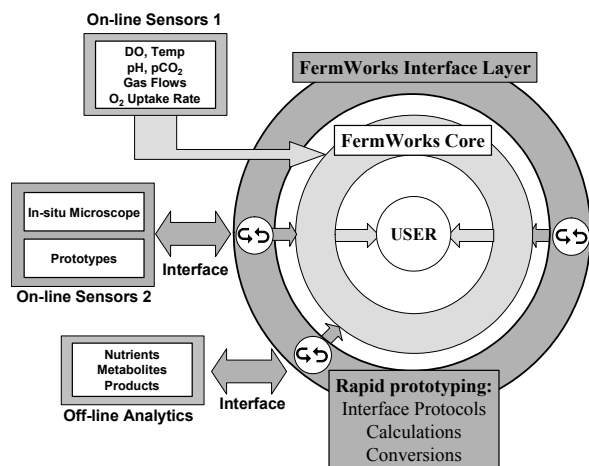

Fig 1. Structure of the FermWorks Components

Specialized calculation requiring multiple inputs from varying sources, like metabolic rates, can also be instantiated in the interface layer in very much the same way as the instrument drivers.

### 7. INTEGRATION OF INSTRUMENTS INTO AUTOMATED DATA COLLECTION

The automation of the result retrieval from standard analytic instrumentation has several advantages:

- Reduction in the workload for technicians and scientists in the process development labs.
- Reduction of the transcription errors during data entry and transfer.
- Timely availability of the analytic results, enabling more advanced process control operations.
- Electronic traceability of every sample processed by the instruments, a reporting requirement commonly found in a production environment that has value as well in process development. An example is the compilation of supporting data for submission to a governing agency after several months or years of research.

All instrument drivers that are part of the FermWorks Interface layer were written in the LabVIEW language. The Cedex, YSI, BGA and offgas-sensors were incorporated utilizing the unique communications protocol provided by each instrument. The instrument drivers were formatted to perform as plug-in code with FermWorks, each being polled at a specified interval to scan for any possible new data at the instrument's data port. Each instrument's data protocol included, along with analytical values, the time of analysis and an identification code corresponding to the bioreactor that provided the sample. The YSI 2700 driver also enabled the tracking of probe calibration data for improved system performance monitoring. This information has previously not been analyzed on a routine basis.

The FermWorks Interface Layer provides a unified platform for rapid prototyping that was carried out by

following the workflow shown in Figure 2. The development passes through several stages each concluding with a decision point (“gated process”). The development work was usually separated into the required features, that are needed to import the data into the control system, and the optional features, that offer additional information for system performance monitoring or remote control.

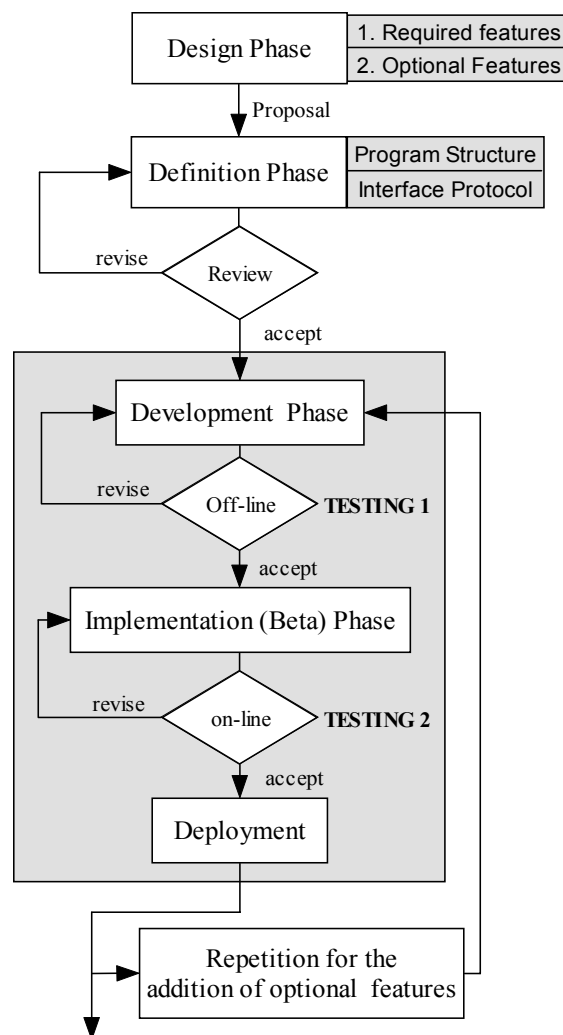

Fig. 2. Interface design workflow

This type of development work went quickly, with an estimated 20 hours development time for the core functionality of each instrument driver, followed by time to integrate and debug the new plug-ins within FermWorks. A stable driver can be established in the system in as little as two weeks.

All instruments were polled via serial or preferably Ethernet ports from a central computer in the FermWorks network facilitating code management, as well as the initial integration efforts without disturbing running fermentations being managed at other computers (Fig. 3). Some instruments were reached via serial ports placed on the local network, creating a Ethernet-Serial bridge. The time required for these drivers to be developed, tested, and integrated was short in comparison to having customized OPC servers written by the instrument manufacturer.

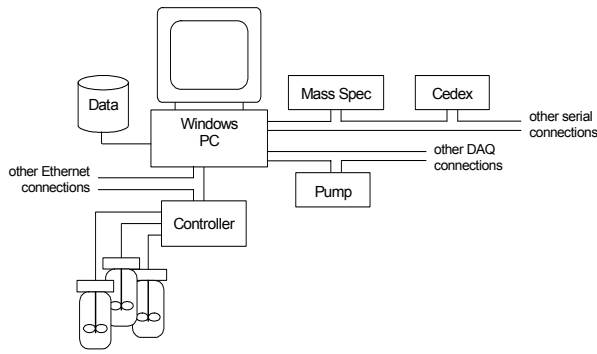

Fig. 3: Schematics of the Instrument connections

The Sartorius In-situ Microscope, a more complex instrument used for cell density measurement, required interfacing to image processing code in addition to the actual instrument control, as described in Figure 4.

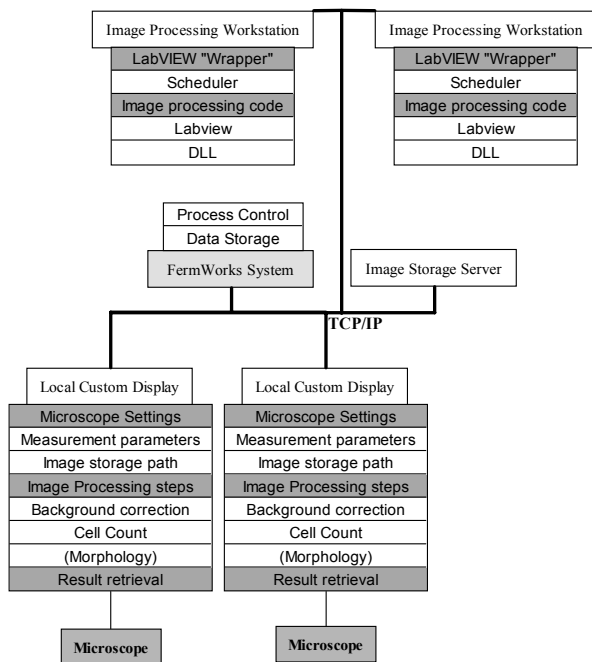

Fig.4: Structure of the In-situ microscope interface

A plug-in captures images to a central storage server and copies them to one or several separate processing computer which determines the cell density from the acquired images in a multi-step process. The results are then send to the FermWorks Core system and made available at the bioreactor control station. The results are also available as inputs for process control tasks.

## 8. SUMMARY

All analysis results returned from various instruments were recorded back to the FermWorks system, allowing researchers to inspect the values returned from every analysis performed by each instrument, at any given computer within the system

When new data were found that matched known bioreactors, the instrument drivers automatically recorded those data in the FermWorks database as Offline Data with corresponding sample timestamps for the appropriate bioreactor. There, the offline data were integrated with local process control and monitoring, and available for editing if necessary.

The established automated process has greatly simplified collection of offline analytical data, and has reduced, if not entirely eliminated, the chance of incorrect data being stored from a give sample. In addition, offline analyses are now available for process control calculations within minutes of being produced by the instrumentation, and an electronic record has been created that tracks each sample processed by the analytical instrumentation.

This approach also allows for fast integration of new technologies as well as instrument prototypes, thus enabling fast and efficient evaluation of new tools without impact on the running process. The data obtained from such new tools are immediately available together with the established data sources, allowing for thorough cross correlation and easier assessment.