

HEAT PUMPS IN DISTILLATION

Dolf Bruinsma and Simon Spoelstra

Energy Research Centre of the Netherlands (ECN), Westerduinweg 3, 1755 LE Petten, The Netherlands

bruinsma@ecn.nl, spoelstra@ecn.nl

Abstract

Vapor recompression has become the standard heat pump technology in distillation and substantial energy savings in the order of 50% have been achieved. Economic applications of VRC are limited to column temperature differences of about 30 °C, which is only one fifth of the across the pinch columns in operation. 2nd generation heat pump systems based on further heat integration and novel heat pump equipment do not only increase the potential energy savings but also extend the application range to columns with a larger temperature difference.

Keywords: heat pump, heat integration, distillation, energy savings

1. Introduction

Distillation is the main separation technology in refineries and the chemical process industry, because of the attractive purification characteristics, the high production capacity and turndown ratio, and the straightforward design procedures. More sophisticated techniques have become state of the art to handle streams with less favourable thermodynamic properties, in particular small relative volatilities and azeotropic mixtures. The high energy demand in bulk distillation columns (1-100 MW) and the low thermodynamic efficiency (5-10%) remain the major drawbacks. A number of improvements have been developed over the years directed at reducing both operating and capital cost.

In extractive distillation (ED) a solvent or separating agent is added in order to increase the relative volatility of the components to be separated. In azeotropic extractive distillation the separating agent is used to break the azeotrope. As a consequence the reflux ratio, column diameter and reboiler duty can be reduced and/or the column height can be lower. Commercial low volatility solvents include sulfolane, triethylene glycol (TEG), NMP and NFM. The recovery cost of the solvent is an integral part of the economy of extractive distillation processes. ED is particularly effective for relative volatilities below 1.2. Industrial examples of ED processes are purification of aromatics in petrochemistry, butadiene recovery in naphtha cracking and separation of cycloparaffins from naphtha^{1,2,3}.

Instead of affecting the thermodynamics of the system also selection of the column internals is a way to increase distillation efficiency. Random and structured packings with specific surface areas from 250 up to 900 m²/m³ are continuously being improved with the objective to optimize stage height, pressure drop, liquid load, and turn down ratio. The main recent advancements in tray columns focus on high-capacity trays with centrifugal devices or structured packing demisters although at the cost of an increased pressure drop⁴.

Since the 1980's dividing wall columns (DWC's) have been introduced which allow the separation of three component feeds in a single column leading to interesting reductions in both energy consumption and investment cost. Recently even more complex DWC's have been constructed to separate four component mixtures in pure products⁴.

In contrast to improvements of the VLE or the column internals, both inside the column, a number of energy reducing measures can be considered outside the column by addressing the reboiler and condenser. These include side reboilers⁵, dephlegmators^{6,7} and heat pumps. Side reboilers use waste heat at a lower temperature than the bottom reboiler and thus increase the exergetic efficiency. Dephlegmators or reflux condensers are compact heat exchangers, such as PFHE's, used to reduce energy consumption in low temperature gas separations. Heat pumps lift the temperature level of the top vapour in order to use this as the heat source for the reboiler. This paper deals with 1st and 2nd generation heat pumps for distillation energy savings.

2. Industrial heat technology

A systematic approach in improving the energy efficiency of industrial processes is the onion-model developed in industrial heat technology. This model is visualized in Figure 1.

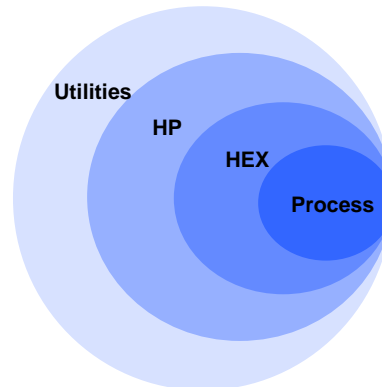

Figure 1. Onion model for energy efficiency improvement

In the first shell the processes occurring in reactors and separators (Process) are optimized with respect to energy consumption. In practice this is done by an economic optimization in which energy and other operating cost are balanced with annualized investment cost for the equipment. In distillation “Process” refers to molecular improvements such as extractive distillation as well as optimization of internals, trays and column compartments.

Energy consumption can be reduced further by heat integration using heat exchangers (HEX). As heat exchangers need a driving force there is a limit to what can be achieved by heat integration. Optimization of the heat exchanger networks is done using pinch technology leading to the rule of thumb: “Do not transfer heat across the pinch temperature”. In addition the “grand composite curve” (enthalpy flow rate versus temperature) provides the minimum total cooling and heating power required for the plant⁸. Now the temperature difference at the pinch temperature, ΔT_{pinch} , is optimized by the economy: a higher value leads to smaller investment cost in heat exchanger area but also to increased utility cost. Since the 1980’s heat integration has become a standard tool in optimizing process designs based on pinch technology. With the introduction of compact heat exchangers in the 1990’s with exchange areas in the range of 200-700 m²/m³ the optimum temperature difference gradually decreased⁹. Currently multi-effect evaporators are in operation having aluminum compact heat exchangers with a temperature difference as low as 1-2 K. The standard heat integration in stand-alone distillation columns is pre-heating the feed with the bottom stream. Further energy savings can be realized between condensers and reboilers of different distillation columns and applying side reboilers.

After heat integration has been optimized, further reduction of energy consumption can be achieved in the third shell: the heat pump (HP). A heat pump is a device that upgrades heat from a lower temperature source to a higher temperature. Originally heat pumps were only used for refrigeration as heating was done by burning cheap fossil fuels¹⁰. Interest to use heat pumps also for heating purposes increased with global awareness of the limited availability of fossil fuels in combination with the greenhouse effect. In fact modern air-conditioning equipment can be used either as a heater in wintertime, pumping up the low temperature outside heat, or as a cooler in summertime pumping the heat inside the building into the atmosphere. This is achieved by reversing the flow of the working fluid.

For a heat pump to be effective there are a number issues to be considered:

- The pinch temperature and the flexibility of the plant
- The thermodynamic cycle and the heat pump efficiency
- The temperature lift required
- The enthalpy balance
- The selection and constraints of heat pump equipment
- The configuration of the system
- The available utilities
- The economy or the annualized capital cost versus the utility cost

3. Distillation column – heat pump configurations

The objective of a heat pump in distillation is to use the heat of condensation released at the condenser for evaporation in the reboiler. As the temperature at the reboiler is higher a heat pump is required. There are essentially two conventional ways to integrate a heat pump and a distillation column: the vapour compression column (VC) and the vapour recompression column (VRC) as shown in Figure 2, together with the conventional column (CC).

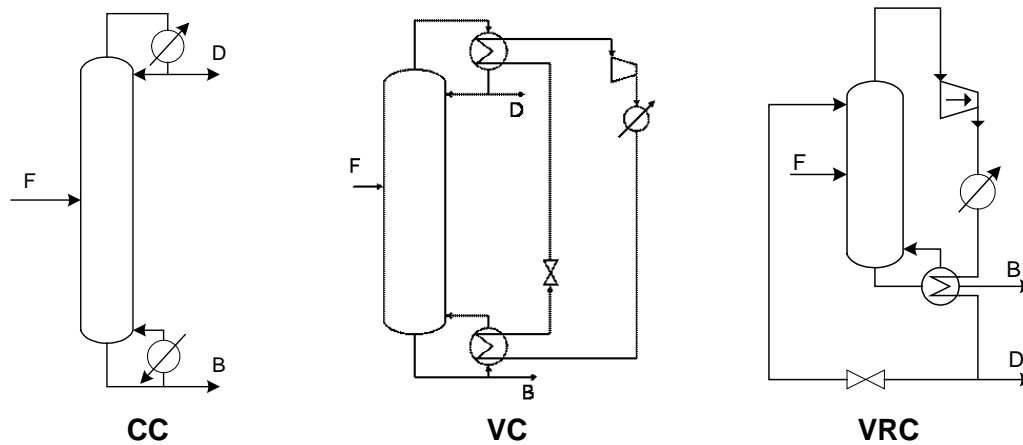

Figure 2. The conventional column (CC), the vapour compression column (VC) and the vapour recompression column (VRC)

In a CC heat is added to the reboiler and extracted in the condenser, while the column is adiabatic. The reboiler and condenser duties are usually in the same order of magnitude¹¹. For close boiling compounds higher reflux ratios are required, which lead to increased duties. As heat pumps are more efficient for smaller temperature lifts, larger energy savings can be obtained for close boiling systems. This implies that in the economic analysis there is a critical temperature lift above which heat pumps are no longer beneficial.

In the VC a working fluid is evaporated at the condenser, compressed to a higher (saturation) temperature, condensed in the reboiler and cooled down by expansion over a throttle valve to a (saturation) temperature below the condenser temperature. Selection of the proper working fluid is an important degree of freedom in the design. An industrial example of a VC is the ethylene-ethane separation using propylene as working fluid¹². In cases where the distillate vapour can not be compressed or in some novel heat pump systems (see par. 5) the VC is the only option.

In the VRC the working fluid is the vapour leaving at the top of the column, which is compressed, condensed in the reboiler and partially refluxed to the top of the column after pressure reduction over a valve. A small trim condenser is needed to balance the heat input, mainly generated by the compressor. An interesting alternative for the VRC is the bottom flash column (BFC)¹³. The advantage over a VC is that the condenser in a VRC is smaller and that the temperature lift is about 5 K lower because heat is exchanged only once. This results in a higher thermodynamic efficiency. Because of these advantages VRC has become the standard technology.

The compression ratio in a VRC depends on the saturation pT-curves at top and bottom composition, the temperature difference over the column, the pressure drop over the column and the required temperature difference for the heat exchanger. How the heat pump is embedded in the distillation column is schematically shown in Figure 3.

The two saturation curves for the distillate and bottoms composition, x_D and x_B , are based on the thermodynamic model. As in most column designs the pressure at the top, p_{top} , is selected first. For the required distillate purity, x_D , the top temperature then is on the x_D saturation curve. The bottom pressure is determined by the column pressure drop and T_{bottom} is on the x_B saturation curve. Now the temperature after the trim condenser, T_E , is determined by the optimized temperature difference over the heat exchanger, ΔT_{HEX} (typically 5K). Assuming that the trim-condenser is used to de-superheat the compressed vapour E is again found at the x_D saturation curve. Finally the temperature lift, pressure ratio and compressor shaft work can be calculated:

$$T_h - T_c = T_{top} - T_E = \Delta T_{column} + \Delta T_{HEX} \quad (1)$$

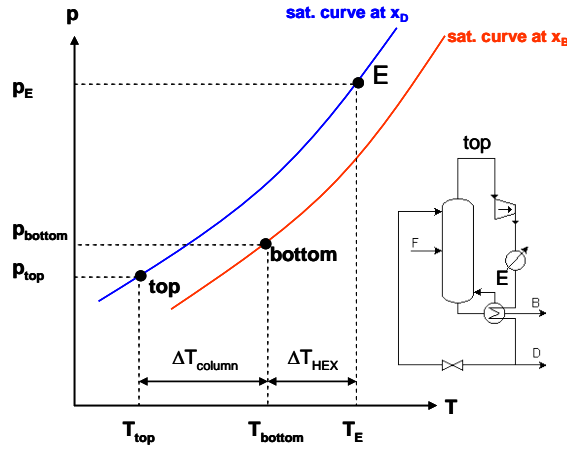

Figure 3. pT-diagram of the VRC cycle

In this paragraph only compressors were considered as heat pumps. These and other heat pump equipment options will be discussed below.

4. Heat pump equipment

Heat pumps are machines that pump heat from a lower to a higher temperature (see Figure 4). From the first law of thermodynamics, the amount of heat delivered to the hot reservoir (Q_h) at the higher temperature (T_h) is related to the amount of heat extracted (Q_c) from the cold reservoir at the low temperature (T_c) and the external work by the following equation:

$$Q_h = Q_c + W \quad (2)$$

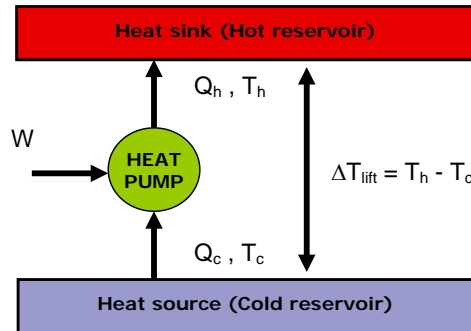

Figure 4. Scheme of a heat pump

The measure of the heat pump performance is the coefficient of performance (COP). For heating applications this is the ratio of heat rejected at high temperature to the work input:

$$COP = \frac{Q_h}{W} \quad (3)$$

The upper theoretical value of COP obtainable in a heat pump is COP_c , related to the Carnot cycle:

$$COP_c = \frac{T_h}{T_h - T_c} \quad (4)$$

Where the temperature lift, $T_h - T_c$, is the sum of the temperature difference over the column and the temperature difference(s) over the heat exchanger(s), as shown in equation (1).

The ratio between the two COP values is the exergetic efficiency of the heat pump, η_e :

$$\eta_e = \frac{W_C}{W_{VRC}} \quad (5)$$

This is visualized in Figure 5 for the Carnot and the VRC cycle in a TS-diagram for the same $Q_h = Q_{reboiler}$.

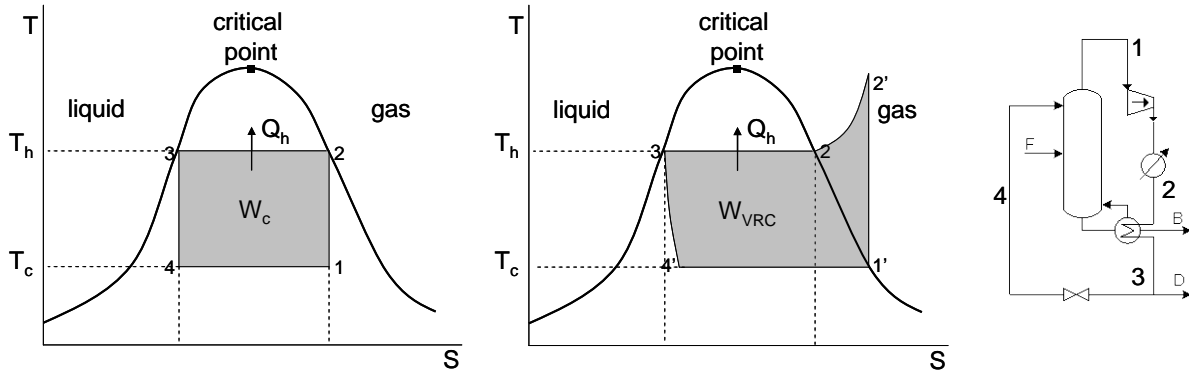

Figure 5. TS-diagram of the Carnot cycle and the reversed Rankin cycle for the VRC

It should be noted that the VRC is an open cycle and the TS-diagrams are therefore a simplification.

Whether a heat pump system actually leads to energy savings depends on the primary energy consumption of both options, PE_{CC} and PE_{HP} . This not only depends on the efficiency of the heat pump but also on the efficiency of the steam boiler, η_{boiler} , and of the power plant that provides the electricity to drive the compressor, η_{el} .

The primary energy consumption for the conventional column equals:

$$PE_{CC} = \frac{Q_{reboiler}}{\eta_{boiler}} \quad (6)$$

For the vapour recompression column this is:

$$PE_{VRC} = \frac{W}{\eta_{el}} = \frac{Q_{reboiler}}{COP \cdot \eta_{el}} = \frac{Q_{reboiler} \cdot (\Delta T_{column} + \Delta T_{HEX})}{\eta_e \cdot T_h \cdot \eta_{el}} \quad (7)$$

The primary energy savings by introducing the VRC for the CC then equals:

$$PES = PE_{CC} - PE_{VRC} = Q_{reboiler} \cdot \left(\frac{1}{\eta_{boiler}} - \frac{\Delta T_{column} + \Delta T_{HEX}}{\eta_e \cdot T_h \cdot \eta_{el}} \right) \quad (8)$$

This equation shows that primary energy savings reduce with increasing column temperature difference. At a certain ΔT_{column} the primary energy savings will not be sufficient to balance the compressor investment cost. At low ΔT_{column} , that is when the column temperature difference is in the order of the heat exchanger temperature difference, it becomes more interesting to invest in compact heat exchangers (as part of the heat pump system) that can operate with a low ΔT_{HEX} .

4. Market analysis of heat pumps in distillation

An analysis was made of distillation heat pump potential in the Netherlands, leaving out columns that do not cross the pinch and oil refinery columns. The data show that the total heat pump potential is in the order of 2.4 GW and that the average temperature lift over the column is 59 °C. These data are given in Table 1.

Table 1. Across the pinch distillation in the Netherlands¹¹

Distillation in NL	
Total Q_{reboiler} (GW)	2.36
Total $Q_{\text{condenser}}$ (GW)	2.39
Average T_{reboiler} (°C)	128
Average $T_{\text{condenser}}$ (°C)	69
Average ΔT_{column} (°C)	59

5. Novel developments in heat pumps in distillation

Conventional heat pump cycles are driven by compressors or blowers depending on the required volumetric capacity and pressure ratio or temperature lift. The economic range for the VRC configuration driven by a compression heat pump is limited to columns with a temperature difference of about 30 °C. New developments in distillation heat pump technology are therefore aimed at novel heat pumps with a higher economic range and at new heat integrated configurations.

5.1 Novel heat pumps

An extensive overview of different heat pumps is given by Dinçer¹⁴, mainly described from a refrigeration perspective. Here only three versions will be discussed as they have the potential capacity of interest for distillation: the thermoacoustic, the compression-resorption and the adsorption heat pump.

The Thermoacoustic heat pump

An electrically driven Thermoacoustic (TA) heat pump¹⁵ consists of a linear motor that generates an acoustic wave, a resonator that together with the working gas (usually helium) determines the resonance frequency and houses all equipment and two heat exchangers on both sides of the porous regenerator, as shown in Figure 6.

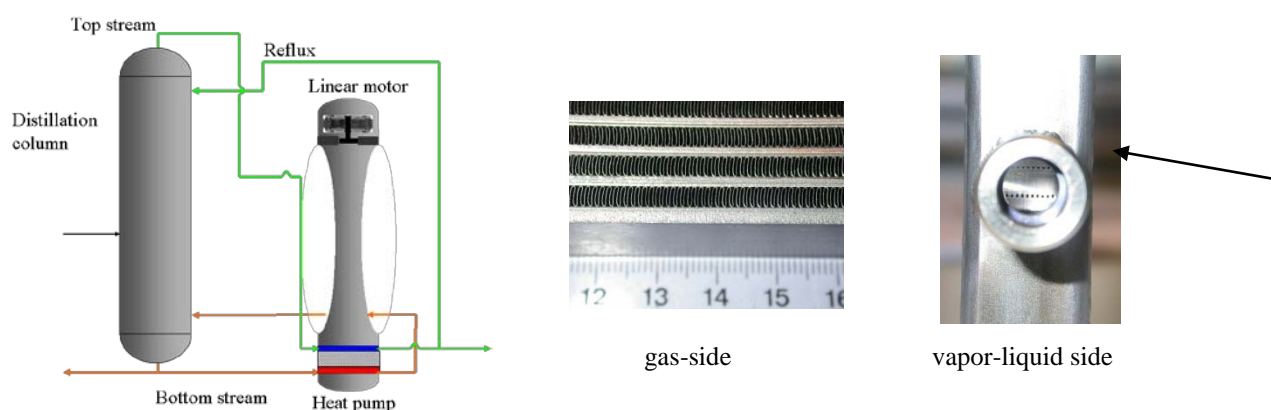

Figure 6. The electrically driven TA heat pump (left) and heat exchanger details (middle and right)

Both compact heat exchangers are flat and located at one end of the resonator, Figure 6 (left). At the TA gas-side a open fin structure is used, Figure 6 (middle). For the vapour-liquid side microchannels connected with a manifold are brazed in between the fins, Figure 6 (right). The TA heat pump can also be driven by a TA-engine instead of a linear motor. The TA engine is driven by steam or a burner.

The Compression-Resorption heat pump

Until now the top and bottom product were considered as pure compounds with fixed condensation temperatures at the operating pressure. In reality one or both products are often mixtures with a condensation trajectory between dew and bubble point; the glide. The temperature difference over the

glide leads to an extra exergy loss over the heat exchanger, unless the working fluid has the same glide. This principle is applied in the Compression Resorption (CR) heat pump.

In the CR heat pump the working fluid is a zeotropic mixture, usually ammonia-water. The composition of this mixture is adjusted until the glide of the working fluid optimally matches the glide at the condenser or the reboiler.

The adsorption heat pump

In an adsorption heat pump waste heat is upgraded in a cycle based on adsorption and desorption of a working fluid onto a low-temperature salt (LTS) and a high-temperature salt (HTS). An example is the system $\text{NH}_3\text{-LiCl}_2\text{-MgCl}_2$ with the cycle shown in Figure 7.

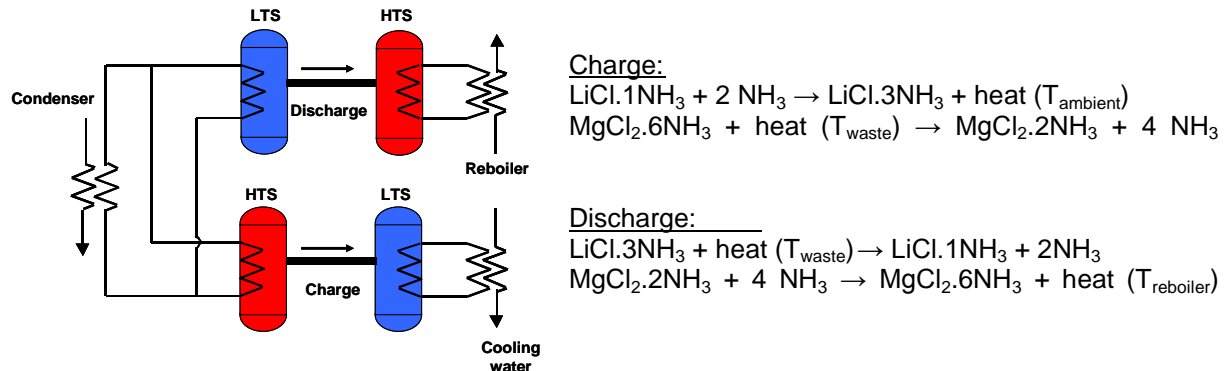

Figure 7. The adsorption heat pump for the $\text{NH}_3\text{-LiCl}_2\text{-MgCl}_2$ cycle ¹⁶.

The adsorption heat pump is essentially a heat transformer with four adsorption columns where waste heat is upgraded to the temperature above the pinch required for the reboiler by adsorption of NH_3 onto the high-temperature salt $\text{MgCl}_2 \cdot 2\text{NH}_3$.

The heat balance shows that for most distillation columns an adsorption heat pump will need an additional heat source.

5.2 Heat integrated distillation columns

A heat integrated distillation column (HIDiC) is diabatic with heat being exchanged in the column from the high pressure rectifier to the low pressure stripper, as shown in Figure 8.

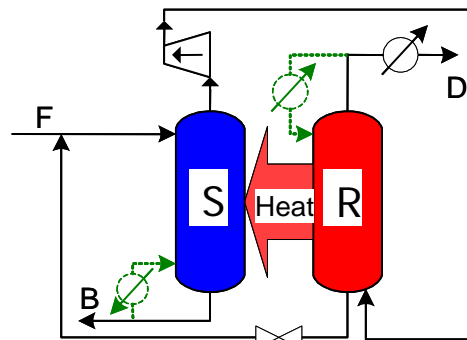

Figure 8. The HIDiC principle

Vapour from the top of the stripping section is compressed and directed to the rectifier. In the rectifier the vapour condenses, creating an internal reflux that is returned to the top of the stripper. The heat of condensation is used to evaporate the liquid at the stripper side. Usually the reboiler duty can be close to zero and a small external reflux is required at the top of the rectifier in order to produce the required distillate purity.

Optimization of the pressure ratio for a constant separation task is based on the balance between the compressor power cost and investment cost for compressor and HIDiC column. The HIDiC configuration can reduce the utility cost compared with the VRC with an additional 25-35% and the total annualized cost with 10-20% ^{17,18,19}.

6. Conclusions

Figure 9 represents the distribution of the reboiler duties in the Netherlands for columns with increasing temperature lift; only those columns that cross the pinch have been included.

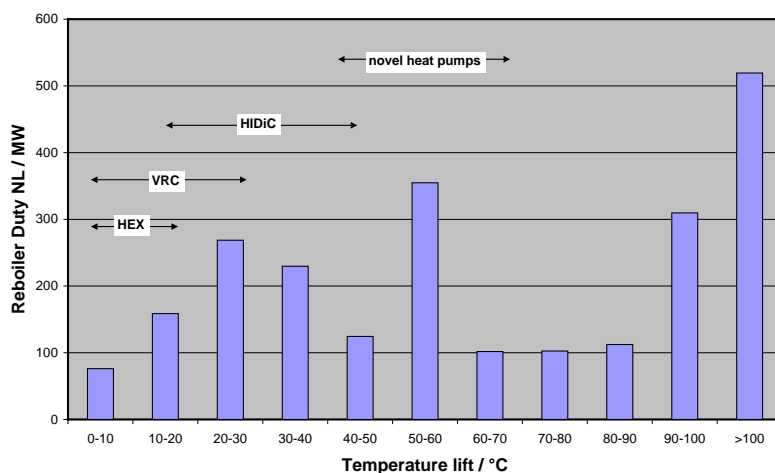

Figure 9. Reboiler duties for across the pinch columns in the Netherlands (2006)¹¹

In the graph four recommendation regions are identified:

- for temperature lifts below 20 °C compact heat exchangers with small ΔT_{HEX} are crucial for the performance of the heat pump system,
- VRC's should be applied below 30 °C, which covers about 23% of the across the pinch columns
- HIDiC's are probably interesting for temperatures in the range 15-45 °C, about 29% of the across the pinch columns, partly overlapping with VRC but with a higher savings efficiency
- novel heat pumps, typically for temperature lifts of 45-70 °C, would contribute an additional 21%

Based on this analysis the combination of VRC, HIDiC and novel heat pumps would lead to an estimated 820 MW savings, which is almost 35% of the reboiler duties of all across the pinch columns in the Netherlands.

References

1. M.F. Doherty and J.P. Knapp, *Distillation, azeotropic and extractive*, In: Kirk-Othmer Encyclopedia of Chemical Technology, Vol. 8, 786-852, Wiley (2004)
2. F.M. Lee, *Extractive distillation*, In: Encyclopedia of Sep. Technol., 1013-1022, Elsevier (2000)
3. S. Kossack et al, *Chem. Eng. Res. Des.*, 86(2008) 781-792
4. Z. Olujic et al, *Chem. Eng. Proc.*, 48(2009) 1089-1104
5. S. Bandyopadhyay, *Chem. Eng. Res. Des.*, 85(A1) (2007) 155-166
6. K. Bakke, *Experimental and theoretical study of reflux condensation*, PhD thesis, NTNU Trondheim (1997)
7. J. Wang and R. Smith, *Chem. Eng. Res. Des.*, 83(A9) (2005) 1133-1144
8. B. Linnhoff et al, *Chem. Eng. Sci.* 38(8) (1983) 1175-1188
9. J.E. Hesselgreaves, *Compact heat exchangers*, Pergamon (2001)
10. M. Zogg, Proc. 9th Int. IEA Heat Pump Conf., 20-22 May 2008, Zürich, pp 1-17
11. J. Cot and O.S.L. Bruinsma, *Market survey, Heat pumps in bulk separation processes* (2010), ECN report 7.6548.2010.0xx
12. Zimmerman, H., Walzl, R., *Ethylene*, Ullmann's Encyclopedia of Industrial Chemistry 7th Ed., John Wiley & Sons, (2009)
13. Z. Fonyo and N. Benko, *Trans IChemE*, 76(Part A) (1998) 348-360
14. I. Dinçer, *Refrigeration systems and applications*, Wiley (2003)
15. G.W. Swift, *Thermoacoustics*, Acoustical Society of America (2002), ISBN 0-7354-0065-2
16. M. van der Pal et al., *Proceedings Heat Powered Cycles Conference*, 7-9 September 2009, Berlin
17. J.A. Hugill et al., *Proceedings 6th Int. Conf. Enhanced, Compact and Ultra-Compact Heat Exchangers*, 12-16 September 2007, Potsdam, pp. 475-482
18. A. De Rijke, *Development of a concentric internally heat integrated distillation column (HIDiC)*, PhD thesis TU Delft, (2007)
19. M. Nakaiwa, *Chem. Eng. Res. Des.*, 81(1) (2003) 162-177