

# Boosting Human Force: A Robotic Enhancement of a Human Operator's Force

Stefan Lichiardopol, Nathan van de Wouw and Henk Nijmeijer

**Abstract**—For a human operator, lifting and carrying a load can be a hazardous task with significant health-related risks. The collaboration between the human operator and a robotic device can provide an effective solution. This study proposes a control design for the robot such that it merely amplifies the force the human operator applies to the load. The algorithm is of a cyclic nature, where each cycle is subdivided into two stages. The first phase is the estimation of the human force, since the only connection between the robot and the human is via the load. In the second phase, the scaled force is applied to the load. The proposed approach is illustrated by means of simulation results for a two-link robot manipulator.

## I. INTRODUCTION

In many fields of industry, human workers are used to transport a load from one point to another. For certain activities, such as on construction sites, luggage handling or even medical care, a human operator has to move heavy loads. Sometimes, the masses of these loads can reach the upper bound of human strength. This is the reason why in most countries legislation has been introduced to set the maximum load that a human operator is allowed to lift and carry (see [1] for the U.S. legislation in this matter, a similar regulation exists in the E.U.). Of course, in some cases, such as the luggage handling, this legislation is very difficult to apply since the masses of the luggage can sometimes be above the upper limit specified by the legislation, yet the company can not discard the baggage (if the owner has paid the over-weight fee).

Another issue concerning this problem is the health risks associated with this task, e.g. back pain. Namely, the human spine and associated muscles and other soft tissues are vulnerable to some types of injury. The lower back in particular is prone to injury, as it is both highly flexible, allowing us to bend and twist in all directions, and subject to a great deal of stress being the main load-bearer of the torso. But in many situations the human presence on the field can not be avoided by using a fully automated robot. Consider again the luggage handling at airports. An automated robot is filling the containers (which are transported to the aircraft) only up to 80% of the entire volume; a human operator has to stack the remaining luggage in the right positions inside the container. Also for stacking the luggage inside the aircraft a human operator is needed for the task since the luggage

compartment of an aircraft differs from aircraft to aircraft and the sizes of luggage pieces vary significantly. Hence human intelligence is needed to complete such tasks.

A possible solution is to develop a robotic device which can aid the human operator by sharing part of the load. Some applications are already available, such as the exoskeletons ([2],[3]), which are dedicated robotic manipulators. One of the problems with this application is that the force the human applies must be known in order to amplify it. However, mounting force sensors on the end effector of the robot is not feasible since the human operator will typically interact with the load directly (and not with the robot end-effector). Various strategies have been considered for force-sensor-less control schemes which estimate the human force. [4] proposes an adaptive disturbance observer scheme, while [5] uses a set of tests for model identification to tune the disturbance observer. [6] and [7] propose a  $H^\infty$  estimation algorithm. Cooperative motion control by human and robot problem is tackled by [8] using the "interactive virtual impedance". In [9], a discussion on the state of the art in force-sensor-less power assist control is presented with an emphasis on the estimation of the human force using linear models for the robot with the load. All the control strategies discussed above assume more or less a perfect knowledge of the dynamics of the robot with the load, i.e. the mass of the load is considered known with very small variations.

The current study introduces a control strategy for a generic robotic device that amplifies the human force. As mentioned before, the robot does not have any direct coupling with the human operator besides via the load, i.e. the robot is supposed to help the human operator by scaling the force the human applies to the load. Here we face two problems: Firstly, the robot should amplify the human force, which is unknown. Namely, the force of the human operator can not be measured because the robot is in contact only with the load, while the human also acts only on the load. This means that the human force has to be estimated. Secondly, in many cases the human deals with loads of different mass, which are also generally unknown. Unfortunately, the estimation of the human force using the encoders from the robot joints depends on the unknown mass of the load ([9], [5]). This research study focuses on designing a control strategy which can solve both problems without using an adaptive control algorithm which present high computational complexity and many parameters to be chosen and tuned. Our algorithm behaves robustly for a large range of variation for the unknown mass of the load.

This paper is structured as follows: The problem statement

This work is done in the frame of the TU/e Teleoperations project.  
S. Lichiardopol, N. van de Wouw and H. Nijmeijer are with Dynamics and Control Group, Department of Mechanical Engineering, Technical University of Eindhoven, 5600 MB Eindhoven, The Netherlands  
Email addresses: s.lichtiardopol@tue.nl,  
n.v.d.wouw@tue.nl, h.nijmeijer@tue.nl

is discussed in Section II. The controller design dealing with the issues of unknown operator force and unknown loads is proposed in Section III. In Section IV, the effectiveness of this method is illustrated by application to a two-link robot manipulator. In the final section of this paper, the conclusions and some perspectives on future research are discussed.

## II. PROBLEM FORMULATION

The problem tackled in this article is robot-assisted load carrying by human operators. The main goal of the robot is to scale the force that the human operator applies to the mass. In that way, the human will 'feel' a load with lower mass but will still be in charge of the position control of the load. When designing a robot control scheme for this purpose we face the following problems:

- The mass of the load is unknown;
- The force that the human operator applies is unknown, since there are no force sensors on the load (the human operator is in direct contact with the load to be transported). The only measurements available are the position coordinates of the robot links.

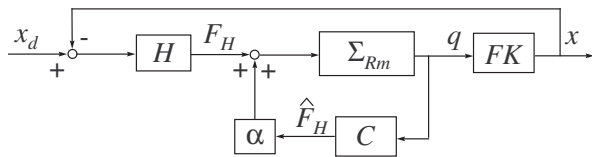

Fig. 1. Problem Setup.

In Figure 1, we present the problem setup in more detail. The human operator has a desired trajectory  $x_d$  (in Cartesian coordinates of the load) in mind and establishes a position control strategy  $H$  so that using the (visual) feedback loop, he can achieve the positioning goal. Using this strategy, the human operator will apply the force  $F_H$  to the load with mass  $m$ . The problem is that sometimes the mass is too heavy for the human to transport or the speed achieved is too low. The assisting robotic device with the load  $m$  is represented by the dynamic block  $\Sigma_{Rm}$ . The controller  $C$ , which will be developed in the next section, estimates the force,  $F_H$ , that the human has applied, using the measurements of the motors encoders from the joints of the robot. This estimated force is amplified by a factor  $\alpha$  and the resulting force is applied to the load, boosting the human operator power. The block  $FK$  represents a forward kinematics block from the joint coordinates to Cartesian coordinates. One can observe the positive feedback loop in Figure 1. We note once more that the human operator is in charge of the path planning and position control.

## III. CONTROLLER DESIGN

The unknown variables in the problem discussed in the previous section are the mass of the load and the human operator's force. The only measurements available are the

joint coordinates of the robotic device. Using this partial information, we have to estimate the human force and the robot should apply an additive force which scales the human force. As the available measurements do not allow a direct control strategy due to unknown parameters and signals (a force control is dependent on the mass of the load), we propose to tackle the problem in two temporal steps:

- 1) Estimate the human operator force;
- 2) Apply the scaled force.

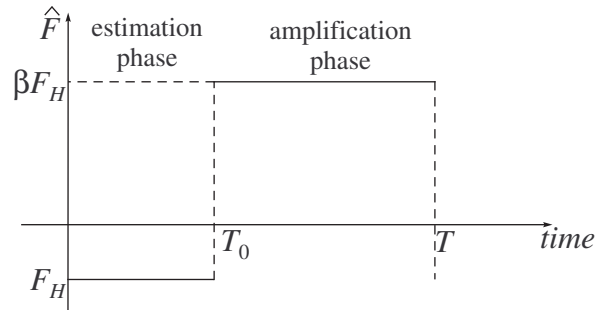

Fig. 2. Temporal Division of the Control Strategy.

The question which arises is how to obtain this temporal division in the algorithm (see Figure 2). In this respect, it is important to note the difference between the frequencies with which a human operator and the robot can perform their tasks. Studies [10] and [11] have shown that a human can perform a task with a frequency of up to 6Hz, much slower than the typical sampling frequency used in a robotic control scheme. This means that if the frequency with which the two steps of our procedure are implemented is higher than 6Hz, than the robotic device can correctly track the force of the human operator and apply the scaled force to achieve its goal.

The force generated by the robot is a signal similar to a Pulse Width Modulation (PWM) signal. Such an input signal generates a series of accelerations and decelerations with a frequency of  $\frac{1}{T}$ , with  $T$  the length of a cycle. This frequency should be set above the maximal frequency that a human can perceive. In [10], it has been shown that a human subject can feel a vibrating object with frequencies up to 300Hz. Unfortunately, no research has been done for the perception of signals other than sinusoidal ones. Moreover, human perception greatly depends on the amplitude of the vibration since for higher amplitudes the perception limit is 300Hz, while for lower amplitudes the sensitivity limit decreases to 40Hz. This information should be also taken into consideration when choosing the parameter  $T$ .

Next, the algorithm for the estimation of the human force is discussed in Section III-A, whereas the algorithm effectuating the amplification of the human force is presented in Section III-B.

### A. Human Force Estimation

Consider the nonlinear system dynamics of the robot with an additional load  $m$  at its end-effector, which are described

by:

$$M(q)\ddot{q} + D(q, \dot{q}) = \tau + J^T(q)F_H, \quad (1)$$

where  $q \in \mathbb{R}^n$  is the vector of generalized joint displacements,  $\dot{q} \in \mathbb{R}^n$  is the generalized joint velocity vector,  $\ddot{q} \in \mathbb{R}^n$  is the generalized joint acceleration vector,  $\tau \in \mathbb{R}^n$  is the robot torque vector,  $F_H \in \mathbb{R}^d$  is the human operator's force vector ( $d$  is the space dimension,  $d = 2$  for 2D or  $d = 3$  for 3D),  $M \in \mathbb{R}^{n \times n}$  is the symmetric, positive definite inertia matrix,  $D \in \mathbb{R}^n$  is the vector containing the sum of centripetal, Coriolis, friction and gravitational forces/torques and  $J \in \mathbb{R}^{n \times d}$  is the Jacobian matrix relating the end-effector velocity  $\dot{x} \in \mathbb{R}^d$  to the generalized joint velocity  $\dot{q}$  by  $\dot{x} = J(q)\dot{q}$ . For the sake of simplicity, we assume that:

*Assumption 1:* The Jacobian matrix  $J$  is nonsingular at all times of operation.

The above assumption means that we do not consider redundant robots (i.e.  $d = n$ ) and no kinematic singularities are encountered.

The objective of the estimation phase is to define a vector  $\hat{F}_H \in \mathbb{R}^n$ , called human force estimation vector, such that  $\lim_{t \rightarrow \infty} \|F_H - \hat{F}_H\| = 0$ . Hereto, we design an estimation

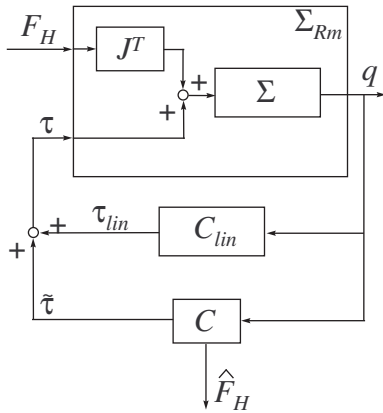

Fig. 3. Human Force Estimation Scheme.

controller strategy as schematically depicted in Figure 3, where the controller  $C_{lin}$  has to compensate for the dynamics of the links of the robot without the load and the controller  $C$  has to estimate the human force  $\hat{F}_H$  using a negative feedback, with  $\tau = \tau_{lin} + \tilde{\tau}$ , where  $\tau_{lin}$  and  $\tilde{\tau}$  are the outputs of the controllers  $C_{lin}$  and  $C$  respectively.

Equation (1) can be written as:

$$M_R(q)\ddot{q} + D_R(q, \dot{q}) + mP_M(\ddot{q}, \dot{q}, q) = \tau + J^T(q)F_H, \quad (2)$$

where  $M_R$  and  $D_R$  contain the information concerning the robot dynamics without the end-effector load,  $m$  is the unknown mass of the load and  $P_M$  represents the remaining terms which depend on the mass of the load. One can observe that in this setup the scalar  $m$  is multiplied with the vector function  $P_M$ . The writing of the multiplication  $mP_M(\ddot{q}, \dot{q}, q)$  is almost always possible because the inertial, the gravitational, the centripetal, the Coriolis and the friction forces are typically linear with respect to the mass  $m$ .

The controller  $C_{lin}$  is designed as follows:

$$\tau_{lin} = M_R(q)\ddot{q} + D_R(q, \dot{q}). \quad (3)$$

Introducing relation (3) in (1) leads to:

$$mP_M(\ddot{q}, \dot{q}, q) = \tilde{\tau} + J^T(q)F_H, \quad (4)$$

where  $P_M$  and  $J$  are known and we have to design  $\tilde{\tau}$ , the output of controller  $C$ , such that, independent of the magnitude of the unknown mass of the load, estimation of the signal  $F_H$  can be achieved.

Let us define  $\hat{F} := J^{-T}\tilde{\tau}$ , then relation (4) becomes:

$$mJ^{-T}(q)P_M(\ddot{q}, \dot{q}, q) = \hat{F} + F_H. \quad (5)$$

If we define  $\eta^{(p)} := J^{-T}(q)P_M(\ddot{q}, \dot{q}, q)$ , with  $p \geq 1$  a constant integer and  $\eta^{(p)}$  denoting the  $p^{\text{th}}$  time-derivative of  $\eta$ , then equation (5) is equivalent to the linear system of equations:

$$m\eta^{(p)} = \hat{F} + F_H. \quad (6)$$

Solving the estimation problem for the linear system (6) is straightforward if we consider the controller strategy:

$$\hat{F} = - \sum_{i=0}^p K_i \eta^{(i)}, \quad (7)$$

with  $K_i$  being positive semi-definite diagonal matrices.

Let us consider the output of the system as  $\hat{F}_H = K_0\eta$ , the estimated human force. Using the transformation of all signals to the Laplace domain  $F(s) = \mathcal{L}(f(t))$ , where  $\mathcal{L}(\cdot)$  is the Laplace operator,  $s \in \mathbb{C}$ , the dynamics of the system from Figure 3, with the input  $F_H$  and output  $\hat{F}_H$  is given by:

$$\begin{cases} ms^p \eta(s) = -(K_0 + K_1s + \dots + K_p s^p) \eta(s) + F_H(s) \\ \hat{F}_H(s) = K_0 \eta(s) \end{cases} \quad (8)$$

The system (8) is input-output decoupled, due to the fact that the matrices  $K_i = \text{diag}(K_{i,1}, \dots, K_{i,k}, \dots, K_{i,n})$ ,  $i = 0, \dots, p$ , are diagonal matrices, with the transfer function from the input  $F_{H,k}$  to the output  $\hat{F}_{H,k}$  given by :

$$H_k(s) = \frac{\hat{F}_{H,k}(s)}{F_{H,k}(s)} = \frac{K_{0,k}}{(m + K_{p,k})s^p + K_{p-1,k}s^{p-1} + \dots + K_{0,k}}, \quad (9)$$

for  $k = 1, \dots, n$ , with  $n$  the number of coordinates. For system stabilization, the parameters  $K_{i,k}$  have to be chosen such that the polynomial denominators of the transfer functions  $H_k(s)$  are Hurwitz, independently of the value of parameter  $m$  within given bounds. The estimation problem is solved exactly for constant human forces  $F_H$  since  $\lim_{s \rightarrow 0} H_k = 1$ , which means that  $\lim_{t \rightarrow \infty} F_H - \hat{F}_H = 0$ , for constant  $F_H$ .

The choice of the parameter  $p$  and the gains in the matrices  $K_i$  is done such that  $|H_k(j\omega)| \approx 1$  up to a frequency above the typical frequencies in  $F_H$ , the human force signal. The bandwidth of the estimation algorithm is dependent on the unknown parameter  $m$ , see (9), but if its upper and lower bounds,  $m_{max}$  and  $m_{min}$ , respectively, are available we can design a controller such that for all the values of the parameter  $m$  within these bounds we can attain the desired bandwidth. If we consider the simplest case with only one

integrator ( $p = 1$ ),  $K_1 = O_n$  and  $K_0 = k_0 I_n$ , where  $O_n$  and  $I_n$  are  $n \times n$  zero- and identity-matrices, respectively, then on each input-output channel the transfer function is given by  $\frac{k_0}{ms+k_0}$ . The absolute value  $|H_k(j\omega)|$  is approximately 1 for frequencies below  $\frac{k_0}{m}$ . Knowing that the parameter  $m \in [m_{min}, m_{max}]$ , we can choose the parameter  $k_0$  such that for any  $m \leq m_{max}$ , the system has a sufficiently large bandwidth (typically above 6Hz).

If we adopt the notation  $\int^k f(t)dt^k = \int_0^t (\int_0^{t_k} \dots (\int_0^{t_2} f(t_1)dt_1) \dots dt_{k-1}) dt_k$ , then the estimation control algorithm is described by (see Figure 4):

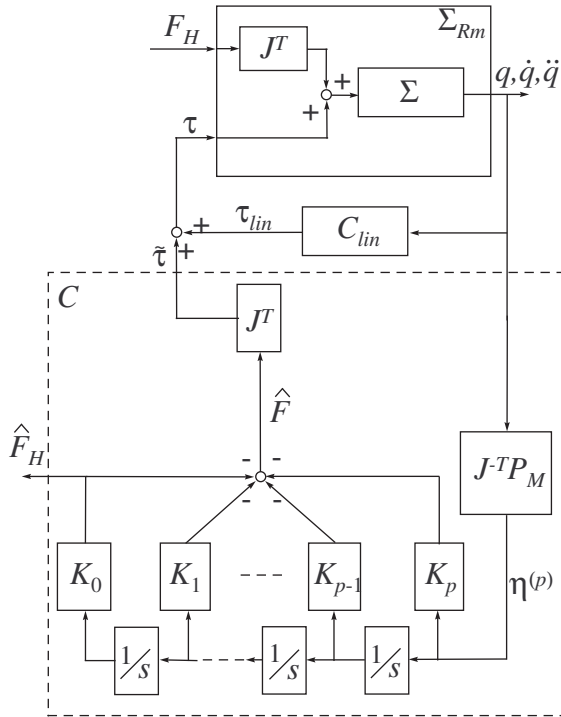

Fig. 4. Human Force Estimation Controller.

$$\begin{cases} \tau = M_R(q)\ddot{q} + D_R(q, \dot{q}) - J^T \sum_{i=0}^p K_i \int^i J^{-T}(q) P_M(\ddot{q}, \dot{q}, q) dt^i \\ \hat{F}_H = K_0 \int^p J^{-T}(q) P_M(\ddot{q}, \dot{q}, q) dt^p \end{cases} \quad (10)$$

The goal of this part of the algorithm is to estimate the human force. Herein, estimation time is also an issue. Besides the frequency domain analysis, a time response should be considered when choosing the gains of matrices  $K_i$  such that the settling time should be lower than the time  $T_0$  allocated to the estimation phase, see Figure 2.

*Remark 1:* In this section, we have chosen to estimate the human operator's force, but it is also possible, using the same approach to estimate the torque applied by the human operator. The choice depends mostly on the specific application, i.e. the robot configuration.

## B. Scaling the human force

Based on the maximal human operation frequency, we can determine the period  $T$  of one cycle of the algorithm, which includes the estimation stage and amplification stage, see Figure 2. From the estimation/control strategy one can obtain the settling time for the estimator as  $T_0$  ( $T_0 < T$ ). This means that the scaled force is applied for  $T - T_0$  during one cycle. The strategy we proposed in Section II has set a required scaling factor  $\alpha$ , but during one cycle the scaled force is applied for only a fraction of time ( $T - T_0$ ). Therefore, we have to determine the new scaling factor  $\beta$ , which leads to an overall scaling factor  $\alpha$ .

The human applies the average force  $\frac{1}{T} \int_{kT}^{(k+1)T} F_H dt$ , over the cycle  $k$ .

For the sake of simplicity, we consider the following assumption:

*Assumption 2:*  $F_H$  is constant during each cycle, i.e.  $F_H(t) = F_H(kT)$ ,  $\forall t \in [kT, (k+1)T)$ .

Since  $\frac{1}{T}$  is chosen to be significantly larger than the maximum frequency of human operator, this is a reasonable assumption. Under this assumption, the human applies the force  $F_H(kT)$  and the robot should apply the force  $\alpha F_H(kT)$ , presumably with  $\alpha > 0$ . The robot applies the force  $F_R$ , with:

$$F_R(t) = \begin{cases} \hat{F}(t), & kT \leq t < kT + T_0 \\ \beta \hat{F}_H(kT + T_0), & kT + T_0 \leq t < (k+1)T \end{cases} \quad (11)$$

Under the Assumption 2, when system (8) reaches the steady state all the time derivatives of variable  $\eta$  are zero. This means that  $\hat{F} = -\sum_{i=0}^p K_i \eta^{(i)} = -K_0 \eta = -\hat{F}_H$ . Consequently, the average force supplied by the robot is given by:

$$F_R = \frac{1}{T} (\int_{kT}^{kT+T_0} (-1) \hat{F}_H(t) dt + \int_{kT+T_0}^{(k+1)T} \beta \hat{F}_H(kT + T_0) dt) \quad (12)$$

where  $\beta$  is the scaling factor we have to determine and we have ignored the torque corresponding to the controller  $C_{lin}$  since the human force is supposed to move only the load and not the robot links. Let us suppose that  $\hat{F}_H(kT + T_0) = F_H(kT + T_0)$ , i.e. the estimation is working, then the right-hand side of relation (12) is equivalent to:

$$\frac{1}{T} (\beta(T - T_0)F_H(kT) - \int_{kT}^{kT+T_0} \hat{F}_H(t) dt). \quad (13)$$

The second term is approximately equal to  $T_0 F_H(kT)$  if the settling time of the estimation algorithm is chosen to be significantly faster than  $T_0$ , and the lower the settling time for the estimation procedure, the better the approximation. Using this approximation and the requirement that  $\frac{1}{T} \int_{kT}^{(k+1)T} F_R dt = \alpha F_H(kT)$ , we obtain the following equation from which we can determine the scaling factor  $\beta$ :

$$\alpha F_H(kT) = \frac{1}{T} (\beta(T - T_0)F_H(kT) - T_0 F_H(kT)), \quad (14)$$

or,

$$\beta = \frac{\alpha T + T_0}{T - T_0}. \quad (15)$$

The estimation/force scaling algorithm is now fully defined and the design goals have been reached. The human operator now has a supplementary force at his disposal which can

enhance his performance by manipulating a larger variety of unknown loads.

#### IV. ILLUSTRATIVE EXAMPLE

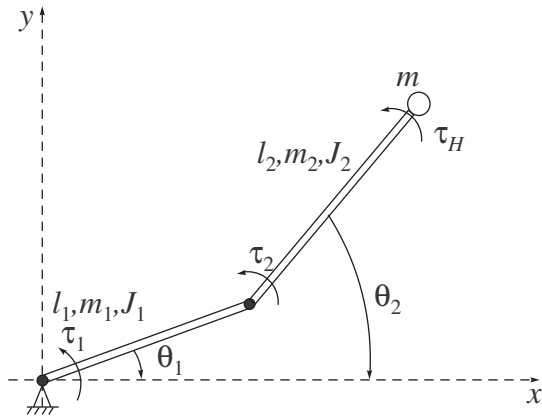

Fig. 5. A two-link robot.

In this section, we will apply the estimation and control design proposed in the previous section to a two-link robot in the horizontal plane, see Figure 5. We assume that the links are rigid and the joints are frictionless. The dynamics of the robot can be described by:

$$M_R(q)\ddot{q} + D_R(q, \dot{q}) + mP_M(\ddot{q}, \dot{q}, q) = \tau + J^T(q)F_H, \quad (16)$$

where  $\tau_H = J^T(q)F_H$  is the torque applied by the human operator,  $\tau = (\tau_1 \quad \tau_2)^T$  are the actuator torque, and:

$$M_R = \begin{pmatrix} J_1 + \frac{m_1 l_1^2}{4} + m_2 l_1^2 & \frac{m_2 l_1 l_2}{2} \cos(\theta_2 - \theta_1) \\ \frac{m_2 l_1 l_2}{2} \cos(\theta_2 - \theta_1) & J_2 + \frac{m_2 l_2^2}{4} \end{pmatrix} \quad (17)$$

$$D_R = \begin{pmatrix} -\frac{m_2 l_1 l_2}{2} \dot{\theta}_2^2 \sin(\theta_2 - \theta_1) \\ \frac{m_2 l_1 l_2}{2} \dot{\theta}_1^2 \sin(\theta_2 - \theta_1) \end{pmatrix} \quad (18)$$

$$P_M = \begin{pmatrix} l_1^2 \ddot{\theta}_1 + l_1 l_2 \ddot{\theta}_2 \cos(\theta_2 - \theta_1) - l_1 l_2 \dot{\theta}_2^2 \sin(\theta_2 - \theta_1) \\ l_1 l_2 \dot{\theta}_1 \cos(\theta_2 - \theta_1) + l_2^2 \ddot{\theta}_2 + l_1 l_2 \dot{\theta}_1^2 \sin(\theta_2 - \theta_1) \end{pmatrix} \quad (19)$$

$$J = \begin{pmatrix} -l_1 \sin \theta_1 & -l_2 \sin \theta_2 \\ l_1 \cos \theta_1 & l_2 \cos \theta_2 \end{pmatrix}. \quad (20)$$

Herein  $l_i$ ,  $m_i$  and  $J_i$  are the length, mass and moment of inertia about the center of mass of link  $i$ ,  $i = 1, 2$ . Moreover,  $m$  represents the mass of the load.

For simulation purposes, we have considered the following parametric settings:  $l_1 = l_2 = 0.6m$ ,  $m_1 = m_2 = 2kg$ ,  $J_1 = J_2 = \frac{m_1 l_1^2}{12} = 0.06kgm^2$  for the robot links. We assume that the mass of the load varies between  $m_{min} = 10kg$  and  $m_{max} = 50kg$ . Knowing that a human operator can not generate signals with a frequency greater than 6Hz, the cycle period for our design is  $T = 0.01s$ .

For the estimation phase, we have chosen only one integrator ( $p = 1$ ) per input-output channel with:

$$K_1 = \begin{pmatrix} -5 & 0 \\ 0 & -5 \end{pmatrix} \quad (21)$$

$$K_0 = \begin{pmatrix} 10^5 & 0 \\ 0 & 10^5 \end{pmatrix} \quad (22)$$

Using this estimation phase, we have observed that the settling time is less than 0.005s, for all the values of parameter  $m \in [10, 50]kg$ , therefore the estimation period  $T_0 = 0.005s$ . The chosen value for the scaling parameter  $\alpha$  is 2, i.e. the robot adds a force equivalent to the double of the human force. Hence, according to relation (15),  $\beta = 5$ .

The simulation setup from Figure 1 contains also the human operator. We have emulated the human behavior by a Proportional-Derivative (PD) controller on each channel with a signal filter for the frequencies higher than 6Hz and saturation bounds on the human force level. The "human" controller on each Cartesian direction has been emulated by a linear transfer function:

$$H(s) = \frac{K_d(T_d s + 1)}{T_{PL} s + 1} = \frac{500(1 + s)}{0.1s + 1}, \quad (23)$$

with saturation at  $\pm 100N$ .

The results obtained by the estimation/control algorithm

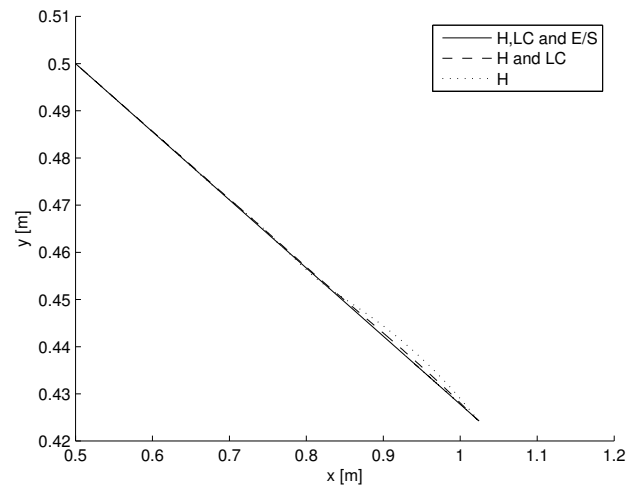

Fig. 6. Load Displacement.

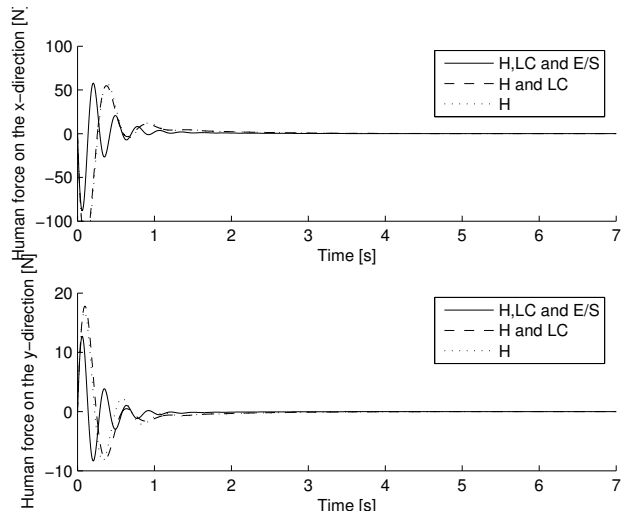

Fig. 7. Human Force.

(Human force(H), compensation for the robot links dynamics(LC) and estimation/scaling algorithm(E/S)) introduced in this article are compared with:

- the use of human force and compensation for the robot links dynamics (H and LC);
- the use of human force (H) alone.

This simulation focusses on two important issues of this comparison: the end-effector displacement (Figure 6) and the applied human force (Figure 7). In all the three cases, the desired set point is achieved in the same amount of time because we have used the same PD controller to emulate the human behavior. Concerning the human force applied, we observe that the only case in which the PD controller does not saturates (see Figure 8 for a focus on the saturation interval of the human force on the  $x$ -direction) is when the estimation/scaling controller(see Figure 9) is used. This means that the human does not need to use the maximal force, i.e. there is a reserve of force which can be used by setting higher gains for the PD controller which will achieve in return the desired set point faster.

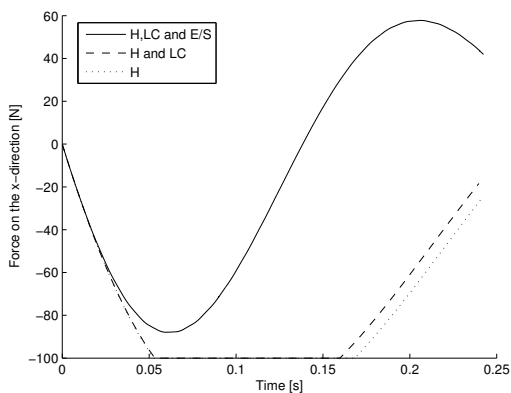

Fig. 8. Human Force Saturation.

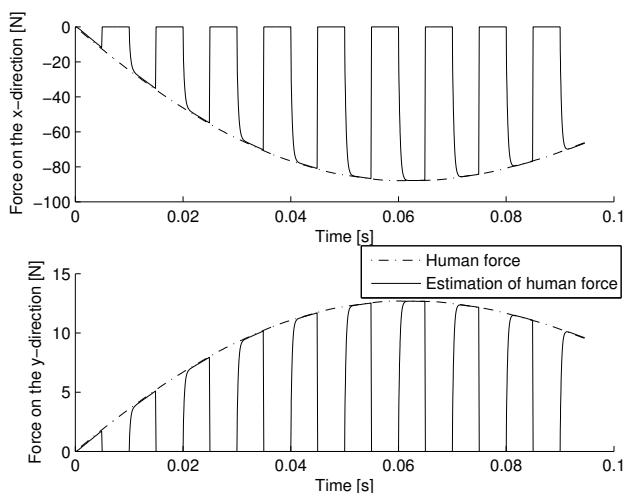

Fig. 9. Human Force Estimation.

## V. CONCLUSIONS AND PERSPECTIVES

In this paper, we have proposed a control strategy for robots aiding humans to lift/move heavy loads of unknown mass. We consider situations in which human intelligence is key in taking care of both the path planning and position control. Therefore, the robot should merely amplify the human force, thereby, firstly, aiding the human speed up its tasks and secondly, alleviating the human efforts.

The key issues in tackling this problem are, firstly, the fact that the mass of the load is unknown and secondly the force applied by the human is unknown. Here, we provide a control /estimation algorithm, which, in a cyclic fashion, first estimates the currently applied human force and , secondly, applies an amplified version of this force. The algorithm can provide a preset amplification of the human force for a range of unknown masses. The proposed strategy is illustrated by application to a two-link robotic example.

The perspectives of this study are:

- the physical implementation of this strategy on a robot manipulator;
- the introduction a feed-forward control for compensating the weight of the load using a monotonously increasing function until the load has achieved lift-off;
- the load is not a point in the end-effector, but a rigid nonhomogeneous body, with torques, momenta of inertia and supplementary dynamics.

## REFERENCES

- [1] J. H. G. Wickes and G. S. Nelson, *Manual Lifting: The NIOSH Work Practices Guide for Manual Lifting*. National Institute for Occupational Safety and Health, 1981.
- [2] N. J. Mizen, "Preliminary design for the shoulders and arms of a powered exoskeletal structure," Cornell Aeronautical Laboratory, Tech. Rep. VO-1692-V-4, 1965.
- [3] J. C. Perry, J. Rosen, and S. Burns, "Upper-limb powered exoskeleton design," *IEEE/ASME Transactions on Mechatronics*, vol. 12, no. 4, pp. 408–417, 2007.
- [4] K. S. Eom, I. H. Suh, W. K. Chung, and S. R. Oh, "Disturbance observer based force control of robot manipulator without force sensor," *Proceeding of IEEE International Conference on Robotics and Automation*, pp. 3012–3017, 1998.
- [5] S. Kobayashi, A. Muis, and K. Ohnishi, "Sensorless cooperation between human and mobile manipulator," *Proceedings of International Conference on Industrial Technology 2005*, pp. 811–816, 2005.
- [6] K. Ohishi, M. Miyazaki, M. Fujita, and Y. Ogino, " $H^\infty$  observer based force control without force sensor," *Proceeding of International Conference on Industrial Electronics, Control and Instrumentation*, pp. 1049 – 1054, 1991.
- [7] —, "Force control without force sensor based on mixed sensitivity  $H^\infty$  design method," *Proceeding of IEEE International Conference on Robotics and Automation*, pp. 1356 – 1361, 1992.
- [8] E. Yamanaka, T. Murakami, and K. Ohnishi, "Cooperative motion control by human and mobile manipulator," *Proceeding of IEEE International Workshop on Advanced Motion Control*, pp. 494–499, 2002.
- [9] S. Oh and Y. Hori, "Generalized discussion on design of force-sensorless power assist control," *Proceeding of IEEE International Workshop on Advanced Motion Control*, pp. 492 – 497, 2008.
- [10] B. A. Kay, J. A. S. Kelso, E. L. Saltzman, and G. Schöner, "Space-time behavior of single and bimanual rhythmical movements: Data and limit cycle model," *Journal of Experimental Psychology Human Perception and Performance*, vol. 13, no. 2, pp. 178–192, 1987.
- [11] T. Miyoshi and A. Murata, "Chaotic characteristic in human hand movement," *Proceedings of the 2000 IEEE International Workshop on Robot and Human Interactive Communication*, pp. 194–199, 2000.