

LOCAL FRICTION FORCES BETWEEN PLUG AND PIPE WALL IN DENSE PHASE PNEUMATIC CONVEYING

Jae Bum Pakh, University of Pittsburgh Pittsburgh, PA USA

George E. Klinzing, University of Pittsburgh Pittsburgh, PA USA

Summary

Dense phase pneumatic conveying is widely used to transport granular materials or powder due to its efficiencies gained on cost and abrasion and erosion. To date these systems have been designed and analyzed using average frictional representation for the conveyed plug. This study explores the effect of this friction force by measuring strains on the pipe wall when the plug is moving passed the region where strain gauges installed on the outer pipe wall. Strains on axial direction of plug flow measured from four different locations, top, bottom, front side, and backside of outer pipe wall. Dynamics strains with the sampling frequency of 10 KHz were measured by using data acquisition card with related software. With this strain, the frictional force can be determined. In this study, comparison the magnitude of the strain under different plug length, and different material transported will be presented. It was found that the magnitude of the axial direction of strain due to the frictional force was affected on the length of the plug. In addition, it was found that the magnitude of strain was different with its measuring location. The plug can now be models with realistic frictional representation of the conveyed plug. Finally, the voidage variation within the plug was calculated based on the Ergun's Equation.

Experiment

Experiment was performed in the 9.3 m long aluminum pipe. Figure 1 illustrates the schematic of the experimental set up. The entire test rig was 9.3 m long with T6061 schedule 40 aluminum pipe. The materials used for this experiment were polystyrene with mean diameter of 5 mm, cubical shape and polyolefin with mean diameter of 4.8 mm, ellipsoidal shape. The material is delivered from a cyclone, and the pneumatic valve between pipe and cyclone enables the materials go into the pipe. Compressed air is supplied to the pipe to transport materials. Two air pressure transducers were installed from 6 m and 8 m away from the pipe entrance and four strain gauges were installed at the strain measurement section. Three rollers support the pipe after the test section to make pipe as a "free end". Since the pipe can move freely to the flow direction when the plug are moving after the test section, the friction force gives tension to the strain gauge, thus strain signal can be determined.

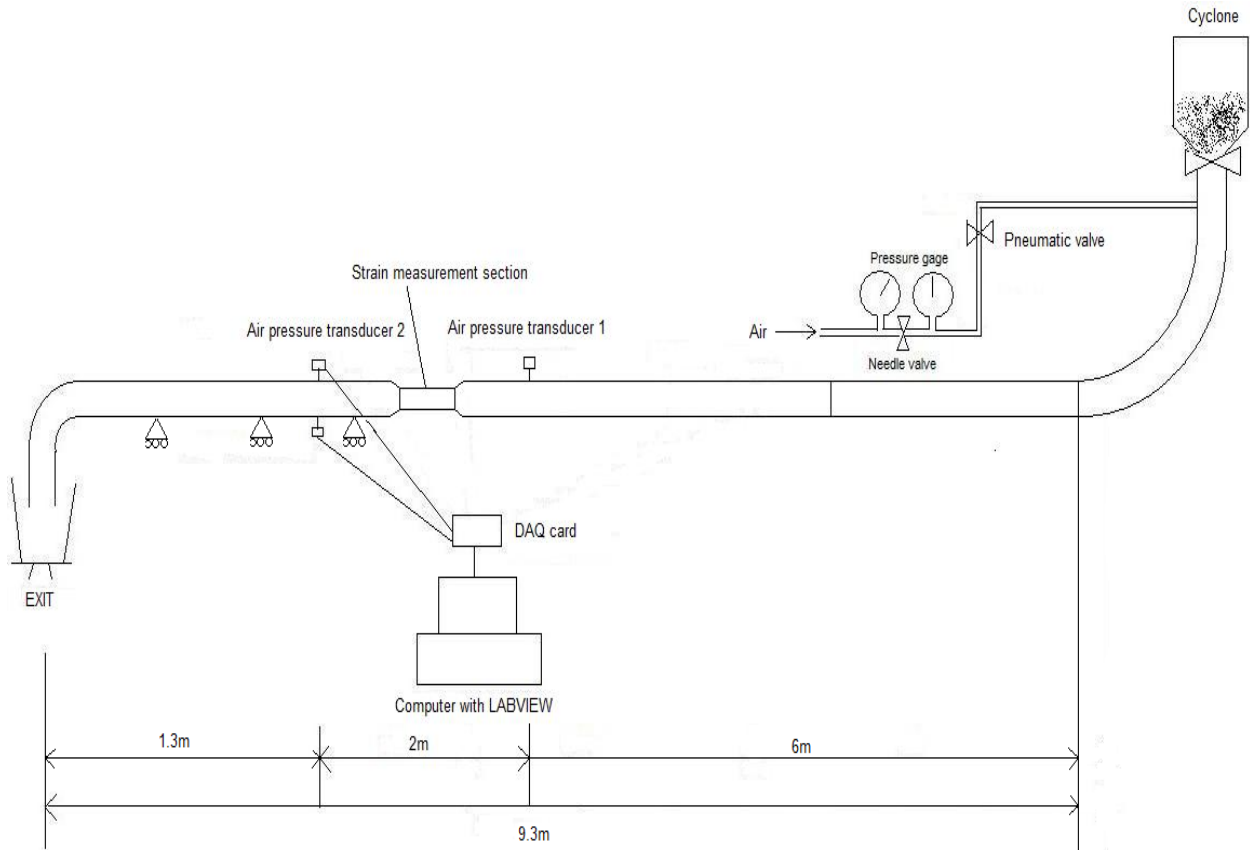

Figure 1 Schematic of test rig

The test section originally designed and assembled with an aluminum block (See Figure 2). This device was not easy to detect the pure axial strain due to the friction force only since the effect of the air pressure was too high. Because the aluminum plate was very thin, it expanded very easily under the air pressure. Next, instead of gluing the strain gauge on the thin aluminum plate, it was glued directly on the inner wall of the pipe, but due to the large and complicate cross-sectional area of the test section, the signal is complicated to be analyzed properly. In addition, there might be a possibility that the strain signal due to the friction was not only between the plug and aluminum block, but also between plug and the strain gauge itself. Thus the whole new strain gauge system design was implemented. The new test section was shown in Figure 2.

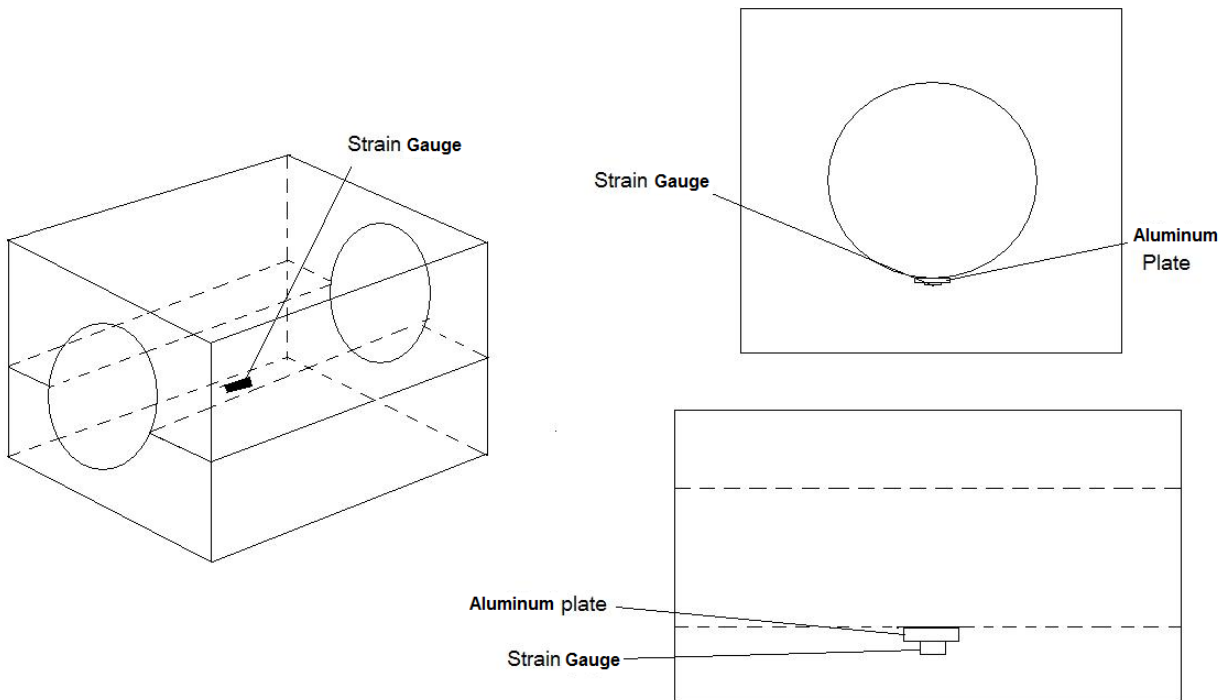

Figure 2 - Strain test section (Original design)

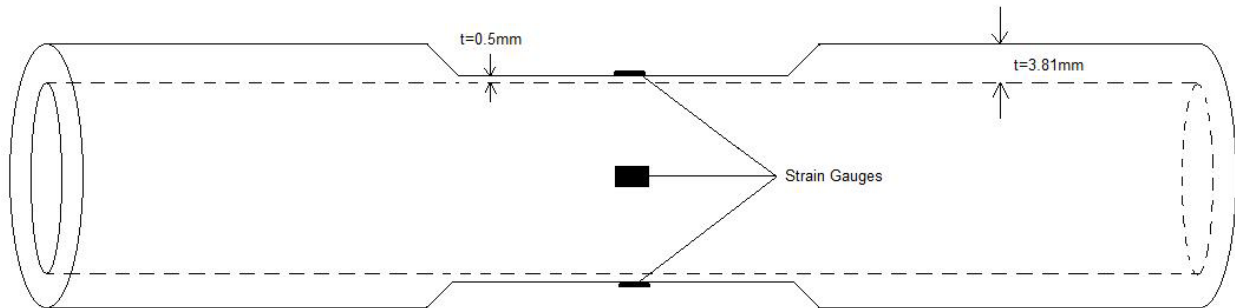

Figure 3 - New strain test section

The new test section where the strain gauges were installed has been milled to 0.5 mm thickness which was much thinner than the original pipe thickness. (3.18 mm) The thinner test section thickness provides larger magnitude strain measurement due to its smaller cross-sectional area. The signal obtained from the strain gauges were amplified for 100 times by AD621 instrumental amplifiers. For each strain gauge, a half bridge configuration was adopted for the purpose of temperature compensation and other signal noise reduction. The sampling frequency for collecting data was 10 kHz (10000 samples / second) and total data acquisition time for each case was 20 seconds. A NI6210 data acquisition cards with LABVIEW from national instrument were used to collect data. For analyzing data for strains and pressures, a MATLAB from Mathworks has used.

The strain signal in this experiment were affected both frictional force and the pressure in the pipe. To convert strain signal to the actual force due to the friction, two different calibrations were performed. The first calibration was to relate force to the strain. To do this, various known weights (4.9N to 29.43N) were hung with pulley on the pipe to generate tensile force on the pipe. Figure 4 is the result of this calibration.

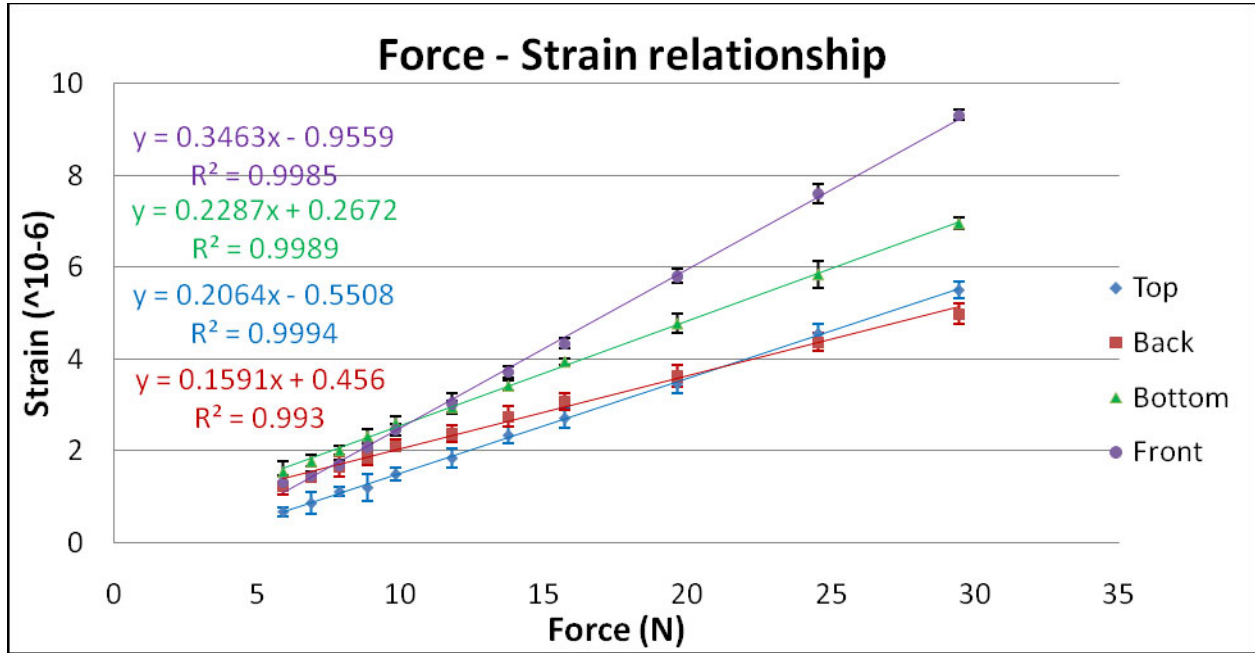

Figure 4 Strain calibration with known weights

The second calibration was to relate strain and the pressure in the pipe. To achieve this, the pipe exit was sealed so that the pipe can be pressurized. The pressure and strain data were collected while pipe was pressurized and related them. From the result on this calibration showed that the effect of the air pressure on the strain measurement was less than 10% thus this study neglect this effect.

To determine the voidage variation along the plug, Ergun's equation was used. The Ergun's equation is defined as follows

$$\frac{\Delta P}{\Delta L} = \frac{150 (1 - \epsilon)^2}{\epsilon^3 d_p^2} \eta U_{slip} + \frac{1.75 (1 - \epsilon)}{\epsilon^3 d_p^2} \rho_f U_{slip}^2 \quad (1)$$

Where $\Delta P/\Delta L$ is a pressure drop per unit length, ϵ is voidage, η is dynamic viscosity of the fluid (air in this study), U_{slip} is particle slip velocity, d_p is mean diameter of particle, and ρ_f is fluid (air in this study) density. Rearrange equation (1) with respect to the voidage, ϵ yields following third order equation

$$\frac{\Delta P}{\Delta L} d_p c^3 - 150\eta U_{slip} c^2 + (300\eta U_{slip} + 1.75\rho_f U_{slip}^2 d_p) c + (-150\eta U_{slip} - 1.75\rho_f U_{slip}^2 d_p) = 0 \quad (2)$$

The pressure data collected from transducers varying with time. The pressure signals from two air pressure transducers enable one to determine the plug length and its velocity by knowing the distance between transducers, time to take when the plug is passing through a pressure transducer and time to take the plug from one transducer to another. After determining the velocity and length of the plug, the pressure gradient and U_{slip} can be determined and the voidage along the plug can be calculated from equation (2).

Result and discussion

1. Strain result

Test were performed under the air velocity of 3 m/s with 600 g, 800 g, 1000 g, 1200 g of polystyrene and 400 g, 600 g, and 750 g of polyolefin as material was transported. Figure 5 shows the force variations along the plug length based on the strains measured at the four different locations. (Top, front, bottom and back of the test section)

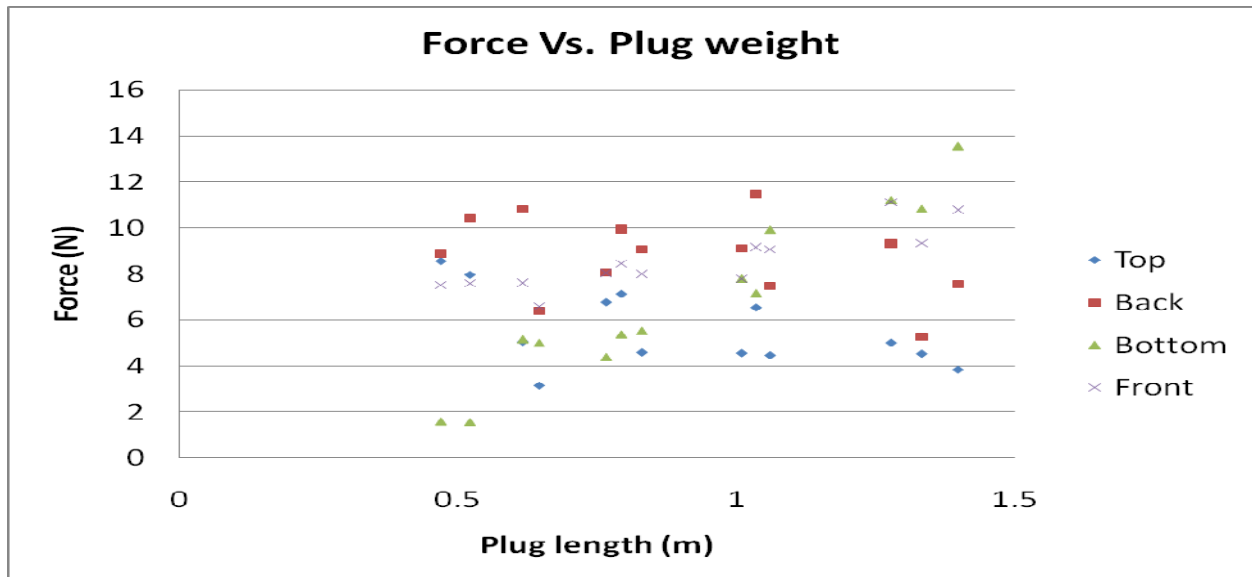

Figure 5 - Force variations with different plug weights (Polystyrene)

From Figure 5, it was observed that the force at the both sides (front and back) were usually higher than the force measured at the top and bottom. At the top of the plug, the particles can be more fluidized than any other sides thus the number of particles that contact the pipe wall would be smaller than other sides yields smaller friction force generated. At the bottom of the pipe, the friction force has a linear relationship to the plug length. Because at this region, increasing plug amount made the particles pack well, thus more gravitational force exists on the bottom. This effect may increase the frictional force. The average frictional force, that is the average of the frictional force applied over the whole cross-sections of the pipe increased when the plug length increased. See Figure 6.

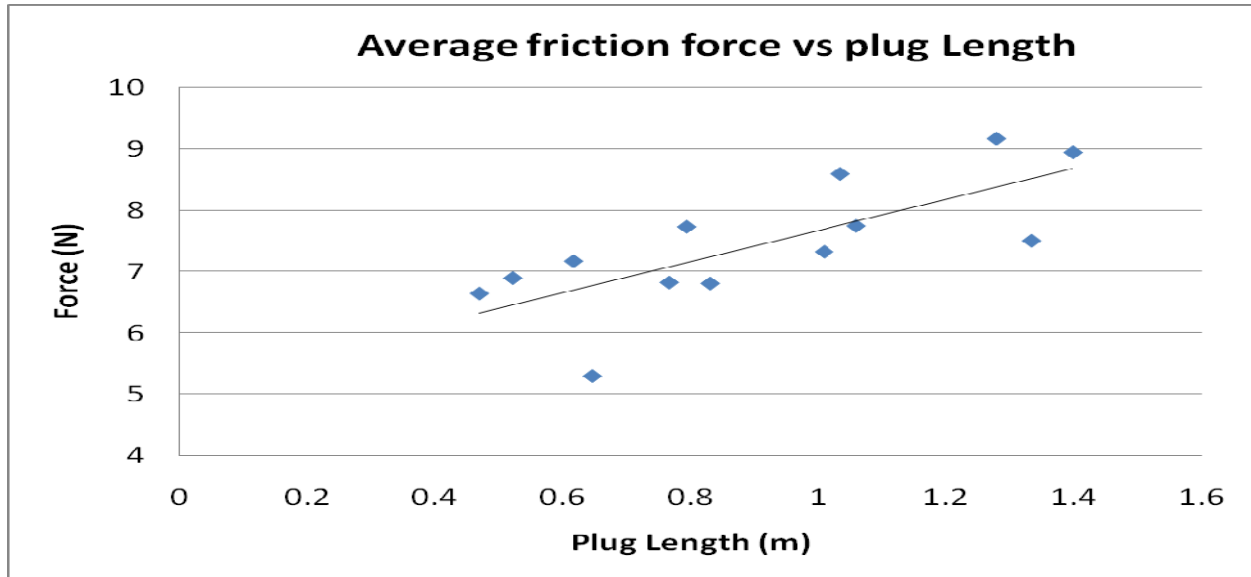

Figure 6 - Average friction force vs plug length, polystyrene.

For polyolefin material, with large amount of plug weight (750 g), the plug length was too long to determine the strain thus it was not able to determine the frictional force. This problem can be solved with longer free end pipe line installed, but this time it will be remained as a future work. Also, the force determined for this particle is very tiny (maximum force measured was 4 Newton) and the number of measurement was small, thus more experiment needed to verify the result. But the behavior of the frictional force with respect to the plug length in each side of the inner wall was similar to the polystyrene.

The limitations of the experiments due to the current system was as follows;

- Air velocity : 3 to 4.8 m/s, if the air velocity is slower than 3 m/s, the plug cannot be conveyed, if it is faster than 4.8 m/s, it is hard to form a plug.
- Plug length : up to 1.8 m, if the plug length is longer, the plug will reach the exit of the system before measure the strain.

Voidage along the plug

The voidage variation along the plug length gave an interesting result. For the polystyrene pellets, in general, higher voidage values were found at the plug front and tail sections and lower at the middle section of the plug. But for the longer plug length, the voidage value was dispersed more than the shorter plug. In addition, the smaller voidage values were found for the longer plug. See Figure 7.

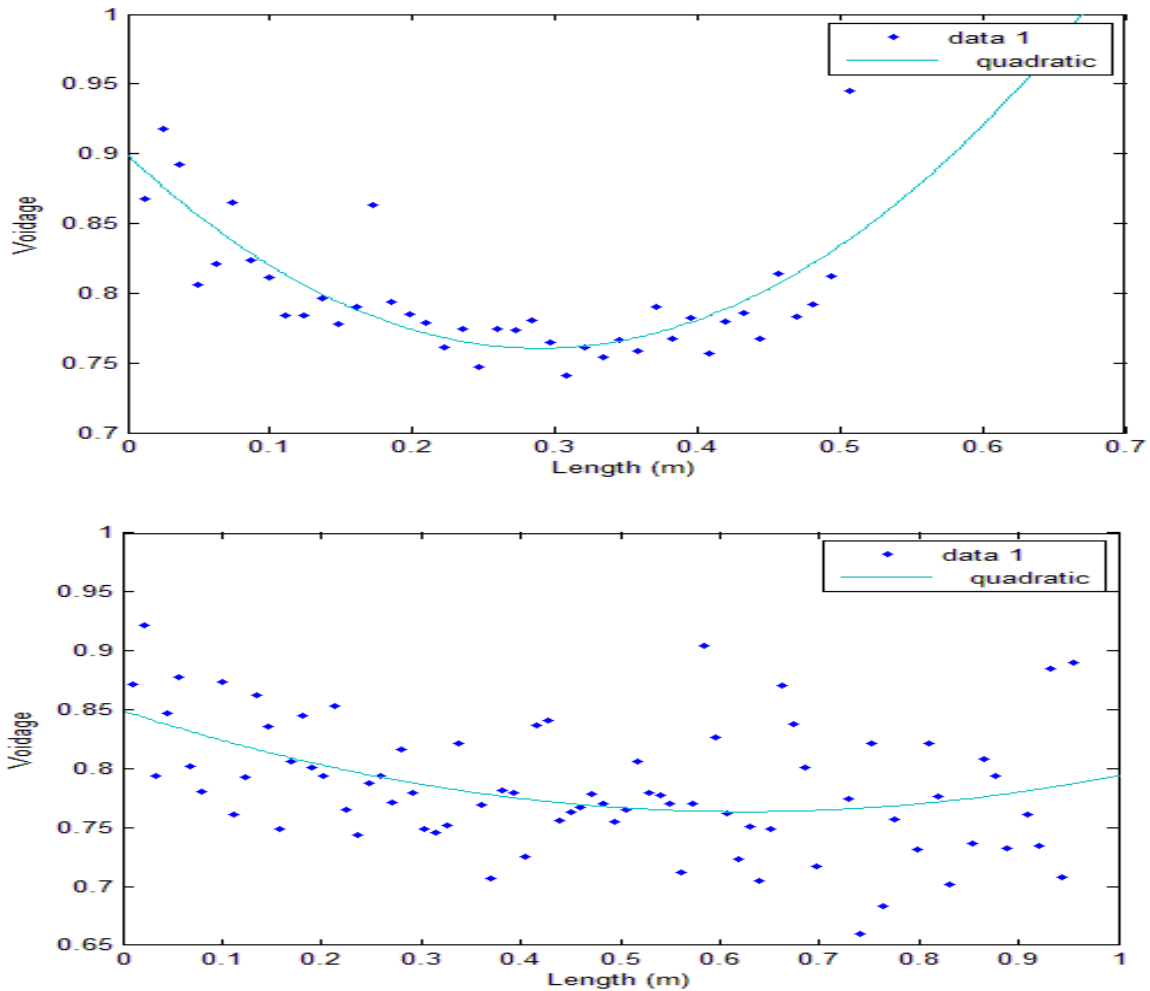

Figure 7 Voidage variation along a single plug, polystyrene.
Plug length = 0.52m (top), 0.97m (bottom)

For polyolefin pellets (Figure 8), in general higher values of the voidage were observed than polystyrene pellets were. No significant voidage difference has been observed with different plug length. In addition, the voidage did not change much within a single plug. The particles were found to be well fluidized in the plug for this material.

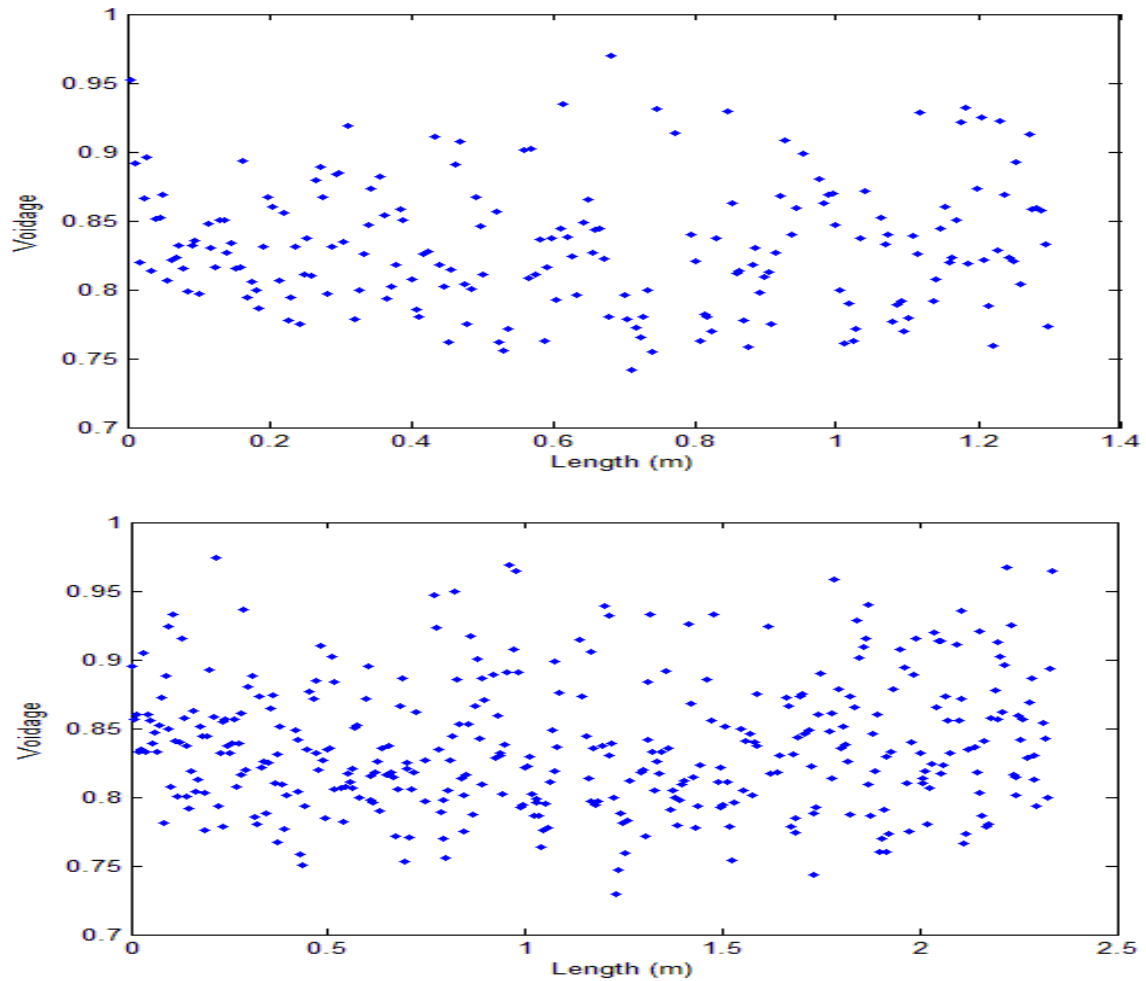

Figure 8 - Voidage variation along a single plug, polyolefin.
 Plug length = 1.32m (Top), 2.35m (Bottom)

Conclusions

During this study so far several conclusions can be drawn:.

- The friction force between plug and pipe wall varies over the cross sectional area of the pipe.
- The friction force at the bottom of the pipe wall has a linear relationship with a plug length.
- The average friction force has a linear relationship with a plug length.
- The voidage determination within the single plug was found that the voidage at the plug front and tail was higher than the middle section of the plug for polystyrene, but no significant change was observed for the polyolefin material.

- With the same amount weight of the conveying material, polyolefin plug were much longer than polystyrene and higher voidage values were observed on this material.

Future work

To develop this study, some suggestions are proposed for future work

- Increasing the free end length will help to investigate frictional force for longer plug.
- Additional data with varying conditions is essential.
- Variation in the transport air velocity will provide a broader scope..
- Explore different materials and particle sizes of the transported material, such as powders.
- Investigation multi-plug conveying to more realistically address the industrial situation.