

# A Master-Slave Approach to Aircraft Engine Bleed Flow Sharing Control

Guangjun Liu<sup>†</sup>, Guozhong Bao<sup>†</sup>, Chun Ho Lam<sup>‡</sup> and Jin Jiang<sup>\*</sup>

Corresponding Author: G. Liu E-mail: [giliu@ryerson.ca](mailto:giliu@ryerson.ca)

<sup>†</sup> Ryerson University, Department of Aerospace Engineering, Toronto, Canada M5B 2K3

<sup>‡</sup> Honeywell Engines & Systems, Mississauga, Canada L5L 3S6

<sup>\*</sup> University of Western Ontario, Department of Electrical and Computer Engineering, London, Canada N6A 5B9

## ABSTRACT

*In this paper, a master-slave control strategy is developed for the flow sharing control of multiple engine systems, applicable to aircraft and industrial plants. Under the proposed control strategy, one of the engine airflow channels is designated as the master control channel, and its pressure is controlled using pressure sensor measurements. The remaining bleed flow channels are treated as the slave flow channels. The air mass flow is also measured in the master channel, and the air flow sensor output of the master channel is utilized to slave the other channels, which are flow-controlled. Since the proposed strategy avoids simultaneous pressure control of multiple channels, the resultant effects of the dynamic coupling among the channels are reduced. Experimental results have confirmed the effectiveness of the proposed control method.*

**Index Terms** – Master-slave control, engine bleed, bleed flow balancing, air flow sharing.

## 1. INTRODUCTION

The development of turbine engines has led not only to advances in thrust generation, but also to the evolution of aircraft pneumatic system design, especially for transport type aircraft. A modern turbine engine is an excellent source of high-pressure and high-temperature air that can be ‘bled’ from the compressors, and then be used for various purposes on the aircraft. These include a wide variety of functions, such as air-conditioning/heating, wing and engine anti-ice protection, as well as windscreen demisting and rain dispersal. Most aircraft utilizing turbine engine propulsion units, both commercial and military, are powered by two or more turbine engines. It has been recognized for some time that

in order to operate a multi-engine aircraft more efficiently, it is desirable to extract bleed air from all of the engines equally, especially when the advanced high performance engines are installed on the aircraft. Engine bleed flow sharing among multiple engines has been attempted in the past based on pressure control of each channel, but with limited success at relatively low steady-state accuracy and slow dynamic responses due to strong dynamic coupling among the channels. The overall system accuracy and efficiency have to be sacrificed to maintain acceptable stability margin of the control system. Bruun [1] discloses a bleed air flow sharing technique for a two engine system that uses a venturi and a pressure sensor to estimate the bleed flow in each engine bleed flow path. The differences in the two flow signals are then conditioned to drive the pressure regulator in each engine bleed flow path. Another two US patents [2] issued to Benson disclose a bleed flow control method for each engine using a pressure regulator upstream of a heat exchanger. Since the bleed air pressure drop across the heat exchanger is a function of the flow rate, the pressure drop is used as the feedback signal to control the flow rate.

Despite all these efforts, balancing bleed flow extraction by the conventional systems has not been entirely satisfactory. The engine required to supply more bleed air will tend to have higher stress and may have to be overhauled or replaced sooner.

In this paper, a master–slave control strategy is proposed and experimentally tested for engine bleed flow sharing control system design. Under the proposed strategy, one of the engine channels is selected as the master channel, and the pressure at the inlet of the systems downstream receiving bleed air is controlled to achieve a desirable inlet pressure range. To slave the

other engines' airflow control channels, the mass flow rate of the master channel is also measured, and the measured master channel airflow rate is utilized as airflow set point for the slave channels, which are flow-controlled. Since the proposed strategy avoids simultaneous pressure control of both channels, the resultant coupling effects among the channels are reduced. In addition, this control strategy enables the flow to be equalized for each engine without the need to know the total flow demand from the systems downstream where the bleed air flow is used. Hence, this control approach is self-contained and can work independently of the ECS (Environmental Control Systems) or other load demands and controllers. The master-slave control strategy can be tailored for a two, three, four or more engine bleed air systems [3]. Experimental results have confirmed the effectiveness of the proposed method.

The concept of master-slave control strategy has been utilized in various areas, such as power electronics. Hur and Nam [4] proposed a robust load-sharing control scheme for parallel-connected pulse width modulation converters and a speed and tension control for a bridle roll system in a steel mill. Rajagopalan *et al.* [5] developed a master-slave current sharing control strategy and applied it to a paralleled DC/DC converter system where an explicit current sharing mechanism is required to ensure proper operation. More applications of the master-slave control concept can be found in [6, 7, 8].

The rest of the paper is organized as follows. In Section 2, an engine bleed flow sharing system is described, and the dynamic model is presented. The proposed control method and analysis are illustrated in Section 3. The proposed control method has been tested in simulation and by experiments, and the results are presented in Section 4 and Section 5. Concluding remarks are included in Section 6.

## 2. ENGINE BLEED FLOW SHARING SYSTEM AND DYNAMIC MODEL

### 2.1 Engine bleed flow sharing system

A simplified illustrative diagram of a two-engine bleed air system (BAS) under consideration is as shown in Fig. 1. To regulate the engine bleed pressure, and to provide over temperature and over pressure protection, the bleed air from each engine passes through a pressure regulation and shut-off valve first. The valve regulates the

downstream pressure before the bleed air passes through a pre-cooler heat exchanger (HX). In this work, we assume that each channel is instrumented with a pressure transducer and a flow sensor downstream the HX. The bleed air flows with lower pressures and temperatures from both channels are merged into one stream to feed the downstream environmental control system or other pneumatic loads.

A conventional control strategy for this system is to control the pressures of the two channels by two separate single-loop controllers, which determine the driving signals of both pressure regulating valves in order to maintain the pressures  $P_{11}$  and  $P_{21}$  within a pre-specified range. This control strategy cannot realize strict and accurate dynamic flow sharing due to the strong coupling between the two flow channels.

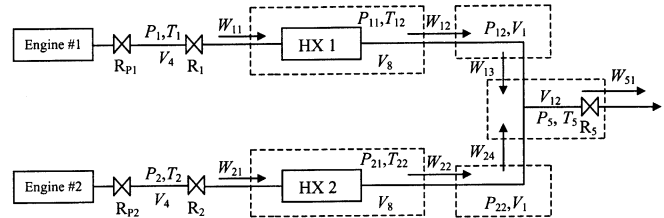

Fig. 1 A two-engine bleed air system diagram

In Fig. 1,  $W$ ,  $P$  and  $T$  denote flow rate in lb/min, absolute pressure in psia and temperature in degree Rankine (Fahrenheit), respectively.  $V$  represents volume in  $\text{in}^3$ .  $R_1$ ,  $R_2$  and  $R_5$  are pneumatic pressure regulators with inner feedback loops.  $R_{p1}$  and  $R_{p2}$  are primary pressure regulating valves.

### 2.2 Linearized model

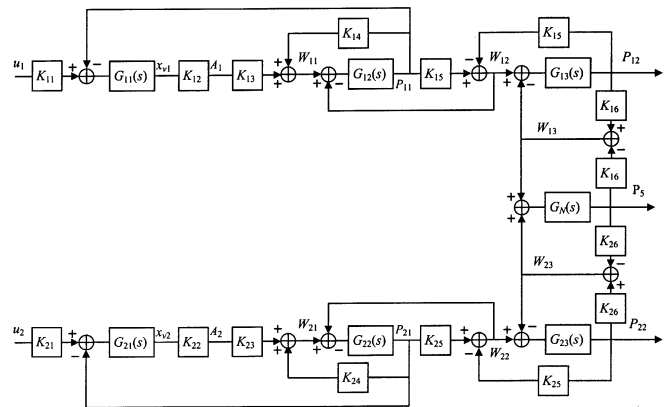

Fig. 2: A block diagram of the bleed air system

For the two-engine bleed air system under consideration, the transfer function block diagram is

shown in Fig. 2. Here the system inputs  $u_1$  and  $u_2$  are the driving currents of the pressure regulators  $R_1$  and  $R_2$ , as indicated in Fig. 1. The transfer functions in Fig. 2 have the following forms

$$G_{11}(s) = G_{21}(s) = k_I(\tau_I s + 1)/(\tau_2 s + 1)$$

$$G_{12}(s) = G_{22}(s) = RT_{12}/(V_8 s)$$

$$G_{13}(s) = G_{23}(s) = RT_{12}/(V_1 s)$$

$$G_N(s) = k_N/(\tau_N s + 1)$$

where  $R$  is the universal gas constant,  $R = 639.6 \text{ in/R}^\circ$ .

For this engine bleed air system, the steady-state operating conditions are as follows:  $P_1 = P_2 = 90 \text{ psia}$ ,  $T_1 = T_2 = 1023.2 \text{ }^\circ\text{R}$  ( $563.2 \text{ }^\circ\text{F}$ ) and a mass flow rate of  $150 \text{ lb/min}$  for each channel, the coefficients in the above transfer functions are listed in Table 1. All the gains in the transfer function block diagram are shown in Table 2.

$k_1$	0.0078	$\tau_I$	0.1 sec
$k_N$	4.5287	$\tau_2$	0.5 sec
$V_1$	$3600 \text{ in}^3$	$\tau_N$	0.0056 sec
$V_8$	$12000 \text{ in}^3$	$T_{12}$	$450 \text{ }^\circ\text{F}$

Table 1: Coefficients in the transfer functions

$K_{11}, K_{21}$	3.000
$K_{12}, K_{22}$	6.383
$K_{13}, K_{23}$	1.435
$K_{14}, K_{24}$	-0.018
$K_{15}, K_{25}$	1.852
$K_{16}, K_{26}$	13.88

Table 2: Gains in the transfer function block diagram

### 2.3 State-space model

By defining the following state variables:

- $x_1$ : channel #1 pressure  $P_{11}$
- $x_2$ : channel #1 pressure  $P_{12}$
- $x_3$ : state variable from  $G_{11}(s)$ ,  
no particular physical meaning
- $x_4$ : channel #2 mass airflow rate  $W_{22}$
- $x_5$ : channel #2 pressure  $P_{22}$
- $x_6$ : state variable from  $G_{21}(s)$ ,  
no particular physical meaning
- $x_7$ : node pressure  $P_5$

The following state-space representation is obtained from the transfer function block diagram of Fig.2:

$$\dot{\mathbf{x}} = \mathbf{Ax} + \mathbf{Bu} \quad (1a)$$

$$\mathbf{y} = \mathbf{Cx} \quad (1b)$$

where the state vector

$$\mathbf{x} = [x_1 \ x_2 \ x_3 \ x_4 \ x_5 \ x_6 \ x_7]^T$$

and the system matrices

$$\mathbf{A} = \begin{bmatrix} -127.96 & 125.75 & 622.10 & 0 & 0 & 0 & 0 \\ 419.16 & -3562.9 & 0 & 0 & 0 & 0 & 3143.7 \\ -0.0126 & 0 & -2.0 & 0 & 0 & 0 & 0 \\ 0 & 0 & 0 & -547 & 5818 & 1152 & -5822 \\ 0 & 0 & 0 & 226 & -3144 & 0 & 3144 \\ 0 & 0 & 0 & -0.0068 & -0.0126 & -2.0 & 0 \\ 0 & 11317 & 0 & 0 & 11317 & 0 & -22815 \end{bmatrix}$$

$$\mathbf{B} = \begin{bmatrix} 2.9316 & 0 \\ 0 & 0 \\ 0.0377 & 0 \\ 0 & 5.4289 \\ 0 & 0 \\ 0 & 0.0377 \\ 0 & 0 \end{bmatrix}$$

$$\mathbf{C} = \begin{bmatrix} 0 & 1 & 0 & 0 & 0 & 0 & 0 \\ 0 & 0 & 0 & 1 & 0 & 0 & 0 \end{bmatrix}$$

The control input vector  $\mathbf{u}$  and the system output vector  $\mathbf{y}$  are

$$\mathbf{u} = [u_1 \ u_2]^T$$

$$\mathbf{y} = [P_{12} \ W_{22}]^T$$

where channel #1 pressure  $P_{12}$ , and channel #2 flow rate  $W_{22}$  are selected as the system outputs.

The eigenvalues of the open-loop system matrix  $\mathbf{A}$  are:

$$\mathbf{A} = [-25988 \ -3578 \ -511 \ -113 \ -5 \ -4 \ -2]^T$$

Since all the eigenvalues are negative, the open-loop system is stable.

### 3. CONTROL SYSTEM DESIGN

The control objectives for the flow sharing control system can be stated as follows:

- (1) To maintain the pressures of all channels within a pre-defined range. For a two-engine system, it can be written as

$$P_{min} \leq P_{i2} \leq P_{max}, \quad i = 1, 2 \quad (2)$$

- (2) To achieve proper flow sharing of the bleed air among all channels with a pre-defined accuracy. For a two-engine system, it can be written as

$$\left| W_i - \frac{1}{2}(W_{12} + W_{22}) \right| \leq \delta_W, \quad i = 1, 2 \quad (3)$$

where  $\delta_W$  is the required flow sharing accuracy.

A conventional control strategy is to control the pressures  $P_{12}$  and  $P_{22}$  separately. With such a control strategy, the pressure controllers can ensure the pressures

$P_{12}$  and  $P_{22}$  to be controlled within a pre-defined range, but it is usually difficult to achieve flow sharing as aforementioned. This is because the strong pneumatic coupling between the two channels through the node, rendering  $P_{12}$  and  $P_{22}$  to be very close to each other. For this control strategy,  $P_{12}$  and  $P_{22}$  have to be controlled to the same magnitude all the time. In such a case, since the pneumatic impedances are small, a small disturbance in engine bleed pressure could cause a large flow difference between the two channels. This means that the flows can deviate from their steady-state operating point rapidly. As a result, the flows may no longer be shared.

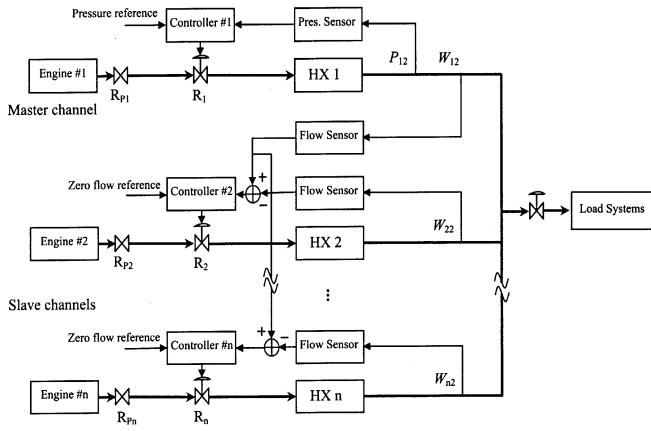

Fig. 3 Master-slave control strategy for bleed air system

With the proposed master-slave engine bleed flow sharing control strategy, any one of the bleed air channels can be chosen as the master channel, and all the remaining channels are treated as slave channels. As shown in Fig. 3, the master channel is pressure controlled, i.e. the pressure at the inlet of the downstream system receiving the bleed air is controlled to achieve a desirable inlet pressure range. The mass flow rate of the master channel is also measured, which can be served as the set point for the flow-controlled slave channels. The master-slave control strategy avoids simultaneous pressure control of multiple channels. In addition, since the flow rate set point for the slave channels is automatically determined by the master channel flow rate, which is governed by the downstream loads, this control strategy enables the flow to be equalized for each engine without requiring the knowledge of the total flow demand from the system where the bleed airflow is used. Hence, this control approach is self-contained and can work independently of the load demands and controllers.

Compared with individual pressure control, the proposed master-slave control strategy turns the slave channels from pressure control to flow control. The resultant strong coupling effects between the two channel pressure  $P_{12}$  and  $P_{22}$  in individual pressure control strategy are reduced considerably by using pressure control in master channel and flow control in the slave channel. In order to implement such a flow sharing strategy among different channels, the flow sensor measurement of the master channel is used as the flow control command signal for the slave channels. Thus, the slave channel controllers do not directly respond to the pressure changes of the slave channels but only after the master channel reacts and provides a flow regulation signal to the slave channels. Note that the pressure and flow in the master channel are still affected by the responses from the slave channels due to the pneumatic coupling through the channel connections.

For the two-engine bleed air system model described in Section 2.3, and without any loss of generality, channel #1 is designated as the master channel, and channel #2 is therefore the slave channel. Assuming that the proportional controllers  $k_1$  and  $k_2$  are used in the master channel and the slave channel, respectively, and the controller output signal  $u_1$  and  $u_2$  can be written as

$$u_1 = k_1 P_{12} \quad (4)$$

$$u_2 = -k_2 (w_{12} - w_{22}) = -K_{15} k_2 P_{11} + K_{15} k_2 P_{12} + k_2 w_{22} \quad (5)$$

In the state feedback form, Eqs. (4) and (5) can be written as:

$$\mathbf{u} = -\mathbf{k}\mathbf{x} \quad (6)$$

where  $\mathbf{k}$  is the state feedback gain matrix.

For the master-slave control strategy, the state feedback gain matrix is

$$\mathbf{k} = \begin{bmatrix} 0 & k_1 & 0 & 0 & 0 & 0 & 0 \\ -1.852k_2 & 1.852k_2 & 0 & k_2 & 0 & 0 & 0 \end{bmatrix} \quad (7)$$

For the conventional pressure control strategy, the controller output signals  $u'_1$  and  $u'_2$  can be written as

$$u'_1 = k'_1 P_{12} \quad (8)$$

$$u'_2 = k'_2 P_{22} \quad (9)$$

The corresponding state feedback gain matrix is

$$\mathbf{k}' = \begin{bmatrix} 0 & k'_1 & 0 & 0 & 0 & 0 & 0 \\ 0 & 0 & 0 & 0 & k'_2 & 0 & 0 \end{bmatrix} \quad (10)$$

Since the master channel is a single-loop pressure control loop in both of the two strategies, this controller can be tuned independently first. Assuming the master controller gain is set to unity, we now examine the influence of the magnitude of the slave channel control gain  $k_2$  on the system performance.

Fig. 4 shows the trajectory of the dominant pole of the closed-loop system as the slave channel control gain  $k_2$  increases. It can be seen that the dominant pole of the closed-loop system moves away from the origin as  $k_2$  increases in the master-slave control strategy. While in the conventional pressure control strategy, the location of the dominant pole of the closed-loop system stays close to the origin as the control gain is increased. This indicates that the dynamic response of the closed-loop system will be faster in the master-slave control than that in the conventional pressure control when higher controller gain  $k_2$  is selected.

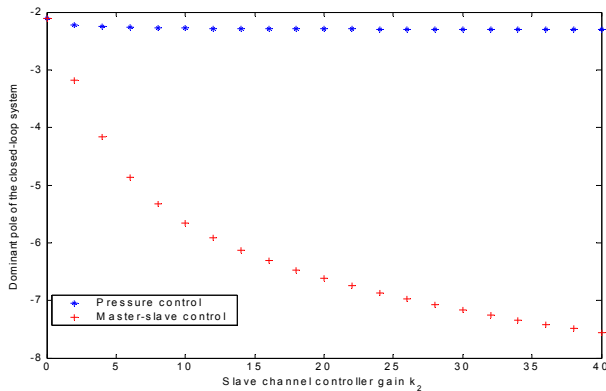

Fig. 4 Trajectory of the dominant pole as the controller parameter increases

#### 4. EXPERIMENTAL RESULTS

A test rig was developed at our laboratory for the flow sharing control studies. The rig consists of four parallel circular pipes, each representing one engine bleed channel. The mass flow rate of each channel is controlled by an electrical control valve, which is installed in each channel. In addition to the control valve, each channel is also equipped with a mass flow sensor, two pressure transducers, and several manual valves for reconfiguring the system. To keep the upstream pressure in the test rig system within a certain range for a certain period of time, a control valve is installed upstream in the test rig. Fig. 5 shows a picture of the test rig. Fig. 6 shows the experimental results of the flow sharing control of the

two-engine system, where a 5 psi step change in the master channel pressure reference is applied to the system. The controller gains are chosen as  $k_1 = 0.08$  for the master channel pressure controller and  $k_2 = 100$  for the slave channel flow controller.



Fig. 5 A test rig for flow sharing control studies

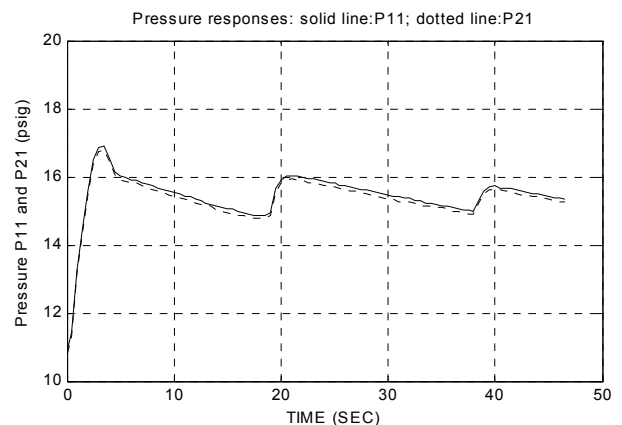
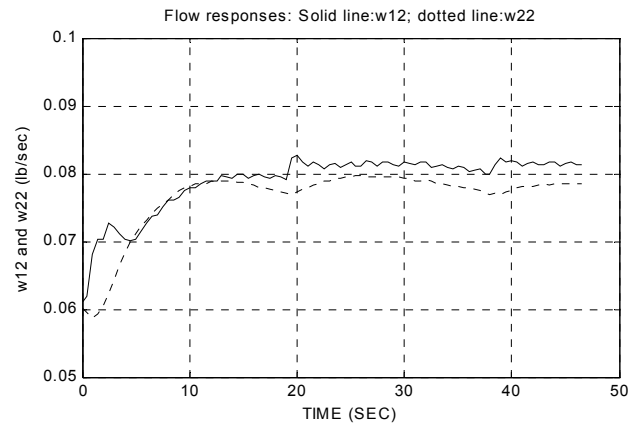

Fig. 6 Experiment results: step change of 5 psi in the master channel pressure reference

Fig. 7 shows the experimental results of the master-slave control, where PI control is used in both the master and the slave channels to help reducing the steady-state errors. The controller parameters are set to  $k_1 = 0.08$ ,  $T_{i1} = 2$  seconds,  $k_2 = 100$ , and  $T_{i2} = 10$  seconds.

Note that the saw-teeth in the pressure responses and flow responses are due to the upstream pressure fluctuation, control valve sensitivity, and sensor accuracy. Because of the slow flow sensor dynamics, which has a time constant of about 10 seconds, the flow responses are slow and there exists a non-minimum phase behavior.

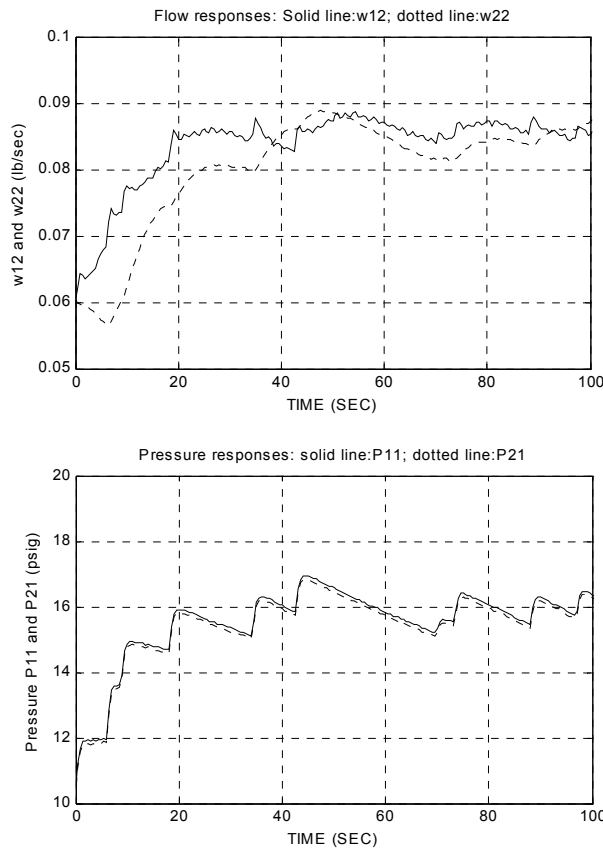

Fig. 7 PI control experiment: step change of 5 psi in the master channel pressure reference

From the experimental results, it can be concluded that, although not being controlled directly, the slave channel pressure is approximately the same as the master channel pressure due to the strong coupling between the two channels. In addition, the mass flow rate of the slave channel follows that of the master channel. When PI controllers are used, there are no steady-state errors in both the pressures and flow rates, which means that the flow sharing is achieved at the steady-state.

## 5. CONCLUSIONS

In this paper we proposed a master-slave control strategy for multi-engine bleed air system flow sharing control. A state-space model of a two-engine bleed air system is derived, and the master-slave controller is designed. Analysis and simulation results show that the proposed control scheme has reduced the strong coupling effect among channels when compared with conventional individual pressure control. Experimental results of a two-engine bleed air system have demonstrated the effectiveness of the proposed master-slave control strategy.

### Acknowledgment

The authors would like to acknowledge the financial support from Natural Sciences and Engineering Research Council of Canada and Honeywell Engines and Systems.

### References

- [1] E.R. Bruun, "Bleed air flow regulators with flow balance," *US Patent No. 5, 155, 991*, 1991
- [2] P.A. Benson, "Aircraft engine bleed air flow balancing technique," *US Patent Nos. 4,765,131 and 4,765,131*, 1988
- [3] G. Liu and C. Lam, "Master-slave engine bleed flow sharing control method and system," *US Patent Application No. 10/349,434*, 2003
- [4] N. Hur and K. Nam, "A robust load-sharing control scheme for parallel-connected multisystems," *IEEE Transactions on Industrial Electronics*, Vol. 47, No. 4, pp. 871-879, 2000
- [5] J. Rajagopalan, K. Xing, Y. Guo, F.C. Lee and B. Manners, "Modeling and dynamic analysis of paralleled dc/dc converters with master-slave current sharing control," *Applied Power Electronics Conference and Exposition*, Vol. 2, pp. 678-684, 1996
- [6] M. Jordan, "UC3807 load share IC simplifies parallel power supply design," *Unitrode Product and Application Handbook*, pp. 10-237~10-246, 1995-96
- [7] H-R. Wu, T. Kohama, Y. Kodera, T. Ninomiya and F. Ihara, "Load-current sharing for parallel operation of dc-dc converters," *Power Electronics Specialists Conference (PESC)*, pp. 101-107, 1993
- [8] I. Batarseh, K. Siri and J. Banda, "An alternate approach for improving current-sharing in parallel-connected dc-dc converter systems," *High Frequency Power Conversion (HFPC) Conference*, pp. 102-119, 1994