

# LQR–Output Feedback Gain Scheduling of Mobile Networked Controlled Systems

Anthony Tzes and George Nikolakopoulos

**Abstract**—In this article, a time-varying controller for a mobile networked controlled system is designed. The controller architecture relies on an LQR-output feedback scheme. The parameters of the LQR-based cost are adjusted according to the communication latency. The tuning of these weights is accomplished via an LMI-approach, where the objective is to provide a closed-loop system with a specific prescribed stability despite the current measured data-packet transmission-delay. The overall scheme resembles that of a gain-scheduled controller, where the tuning of its gains indirectly depends on the communication latency. Experimental results are offered to highlight the efficacy of the proposed scheme.

## I. INTRODUCTION

Remote client-server control architectures are susceptible to various issues [1], [2] stemming from the need to exchange information over a communication link [3], [4]. These problems expand in applications of integrated control and monitoring, where the communication delays, inserted by the communication network, are time-varying and degrade the system dynamic performance. Especially these problems are obvious in the cases where the information exchange is based on common communication links, where the end user (client and server side) has no apparent influential and immediate control over the provided quality of service (QoS).

In a mobile Networked Control System (moNCS) [1], [5], shown in Figure 1, the client computes the control command  $u(k)$  and transmits it wirelessly to a server-site. The server receives the data after a certain delay, transfers them to the plant, samples the plant's output  $y(k)$  and transmits it back to the client for future processing. The client receives the delayed-output and repeats the aforementioned process. The feedback control law is based on LQR-output feedback and tends to remain a prescribed region of stability for the overall system. Due to the inherent delays in the formulation and transmission of signals between the client and server sides [6], [7], there is a need to investigate the stability of this Time-Delayed System (TDS). For this reason, recent theoretical results stemming from LMI theory [8], [9] will be used, in this article.

This paper is organized as follows. In Section II the system architecture of the mobile networked control system is presented. In Section III theoretical results concerning the calculation of the LQR-output feedback control accounting

for the communication latency via the introduction of LMI-theory are presented. The proposed controller is applied in theoretical and experimental studies at a prototype system, and the results are presented in Section IV, while conclusions are drawn in the final Section V.

## II. CLIENT-CENTRIC MOBILE NCS ARCHITECTURE

Within the considered moNCS architecture presented in Figure 1, the control law is computed remotely at a client computer with the control/response signals transmitted towards/from a server-computer located near the plant. The assumed plants continuous transfer function is  $G(s)$ , while the latency intervals from the client site to the server and reverse are  $\Delta_L^1$  and  $\Delta_L^2$ , respectively. Assuming a sampling period  $T_s$  and an embedded ZOH-device in transferring the discrete signals to the plant, let the discrete controlled systems transfer function be  $G(z^{-1}) = (1 - z^{-1}) \mathcal{Z} \left\{ \frac{G(s)}{s} \right\}$  and  $d_i = \left\lceil \left( \frac{\Delta_L^i}{T_s}, 1 \right) \right\rceil$ ,  $i = 1, 2$ . Essentially,  $d_i$  correspond to the "inserted" delays from the mobile-network infrastructure during the data-packet exchange.

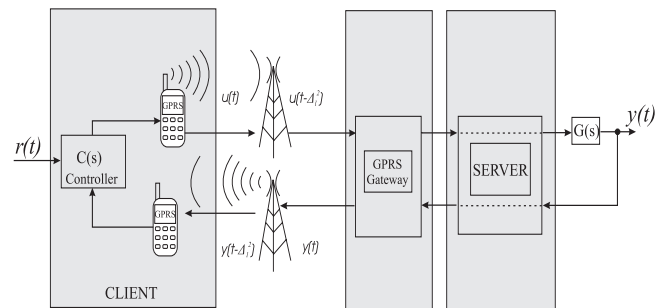

Fig. 1. Mobile Networked Control System Architecture

Within this architecture, the wireless segment poses the most complicated problems to the overall development, since appropriate software drivers must be designed to account for the signaling between the mobile-device and the mobile service provider's network. The client-centric nature [1] of the remote control scheme dictates that the client initiates all data transmissions. Accordingly, the client transmits the control command using the UDP-protocol and records the system's output by issuing an "FTP-get" command. For accommodating the client's requests the server must run locally an FTP-server and must have its corresponding UDP-port opened.

In Figures 2 and 3 we present the procedures ruling the data packet exchange between the client and the server. The

This work was supported by the Herakleitos Research Project, funded by the Greek Ministry's of Education EPEAEK-program.

A. Tzes and G. Nikolakopoulos are with the Electrical and Computer Engineering (ECE) Department, University of Patras (UoP), Patras 26500, Greece. e-mail:tzes(gnikolak)@ee.upatras.gr

UDP-latency and FTP-latency times are noted as  $L^{UDP}$  and  $L^{FTP}$ , respectively.

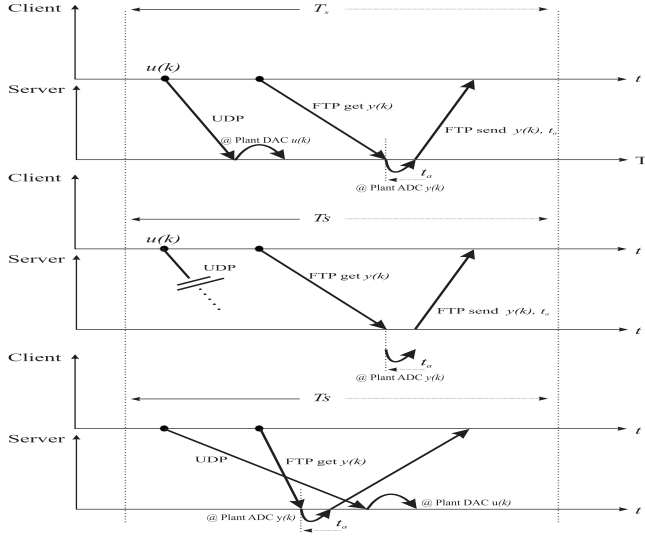

Fig. 2. UDP and FTP Data Packet Exchange Flowchart (Cases 1 thru 3)

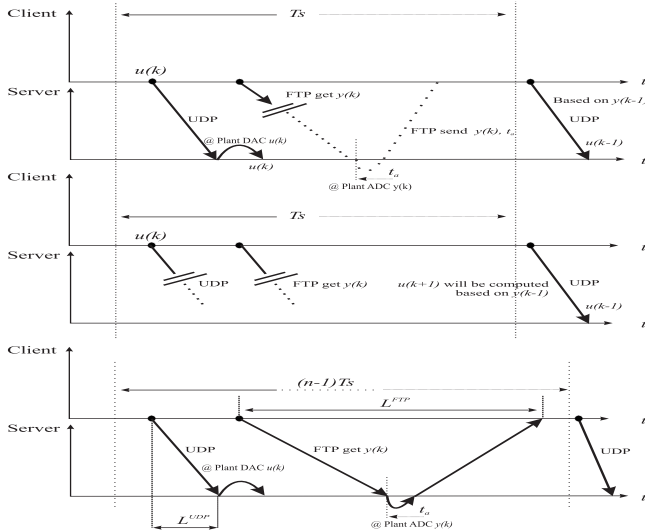

Fig. 3. UDP and FTP Data Packet Exchange Flowchart (Cases 4 thru 6)

The highlighted issues in Figures 2 and 3 display a set of six cases covering possible problems that can be encountered in the data exchange procedure. In Figure 2 the top portion (first case) exhibits "ideal" characteristics: a) the client uses the UDP protocol [10] and transmits the control signal, b) the server receives this packet and converts the digital format of the signal to an analog signal and applies it to the plant, c) after a certain time, the client initiates the FTP-get command and requests to receive through the server, the digitized value of the system's output, d) the server samples the output and sends it back to the client through the opened FTP-connection. In the ideal case, this four-step sequence is completed within one sampling

period  $T_s$ . The second case (middle portion) describes the situation where an instantaneous loss of a UDP-based packet transmission fails. In this case the server applies to the experiment the last correctly transmitted signal  $u(k)$  from the client. In the third case we describe the packet reordering situation, where the UDP-based transmission is delayed and the FTP-based reception has already been initiated by the client.

The fourth case (top portion of Figure 3) corresponds to a situation of an instantaneous loss of FTP-based data acquisition. The UDP transmission is performed correctly, but the client's request for the FTP-get command fails. In this case the client computes the next control signal  $u(k+1)$  based on the previously recorded (and outdated)  $y(k-1)$  output. The fifth case (middle portion) stands for an instantaneous loss of the communication link. During this phase the UDP and FTP data packet are lost. The client computes the next control signal  $u(k+1)$  based on the last correctly received, from the FTP protocol, system output. In the sixth case (bottom portion) we have high latency times due to traffic congestion and the sequence cannot be completed within one sampling period.

### III. LQR-OUTPUT FEEDBACK GAIN SCHEDULING CONTROLLER

Consider a discrete time NCS in a zero-latency environment, with a transfer function given by:

$$\begin{aligned} x(k+1) &= Ax(k) + Bu(k) \\ y(k) &= Cx(k). \end{aligned} \quad (1)$$

#### A. LQR-Output Feedback for NCS

Let the control objective be the computation of an LQR-output feedback controller,  $u(k) = Ky(k)$ , that minimizes the following cost [11]:

$$\min_K \sum_{i=0}^{\infty} [y^T(i)Ry(i) + u^T(i)Qu(i)] e^{\sigma i}, \quad (2)$$

with  $\sigma \geq 1$ . Upon computation of this controller the resulting closed-loop system has its poles ( $\text{eig}(A + BKC)$ ) located inside a disk of radius  $\frac{1}{\sigma}$ . However in an NCS, the actual case corresponds to inserting delays in the loop, and unlike the anticipated control command  $u(k) = KCx(k)$ , the actual applied one is :

$$u(k) = K_{r_s} Cx(k - r_s(k)) \quad (3)$$

where we assume that the overall delay is time varying, since  $r_s(k)$  is a random bounded sequence of integers  $r_s(k) \in [0, 1, \dots, D]$ , and  $D$  is the upper bound of the delay term. The closed-loop system, where  $r(k) = 0$ , is formed by augmenting the state vector to  $\tilde{x}(k)$ , in order to include all the delayed terms, as

$$\tilde{x} = [x(k)^T, x(k-1)^T \dots x(k-D)^T]^T.$$

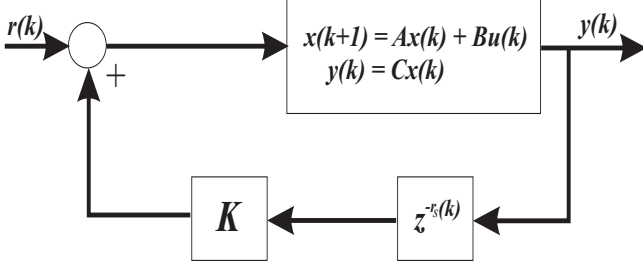

Fig. 4. Model representation of a Time Delayed moNCS

The dynamics of the open-loop system, at time  $k$ , with the augmented state vector take the following form

$$\begin{aligned}\tilde{x}(k+1) &= \tilde{A}\tilde{x}(k) + \tilde{B}u(k) \\ y(k) &= \tilde{C}_{r_s}(k)\tilde{x}(k), \text{ where} \\ \tilde{A} &= \begin{bmatrix} A & 0 & \dots & 0 \\ I & 0 & \dots & 0 & 0 \\ 0 & I & \dots & 0 & 0 \\ \vdots & \vdots & \vdots & \vdots & \vdots \\ 0 & 0 & \dots & I & 0 \end{bmatrix}, \tilde{B} = \begin{bmatrix} B \\ 0 \\ 0 \\ \vdots \\ 0 \end{bmatrix}, \\ \tilde{C}_{r_s}(k) &= [0 \dots 0 \ I \ 0 \ \dots \ 0],\end{aligned}\quad (4)$$

where the vector  $\tilde{C}_{r_s}(k)$  has its elements zeroed, except from the  $r_s(k)$ -th one whose value corresponds to the unitary matrix.

The closed-loop system is switched [12], [13], since  $r_s(k)$  (and thus the feedback term  $K_{r_s}(k)C$ ) is of time-varying nature. The overall closed loop system is

$$\begin{aligned}\tilde{x}(k+1) &= \tilde{A} + \tilde{B}K_{r_s(k)}\tilde{C}_{r_s(k)}\tilde{x}(k) + \tilde{B}r(k), \quad (5) \\ y(k) &= \tilde{C}_{r_s(k)}\tilde{x}(k)\end{aligned}\quad (6)$$

The closed loop matrix  $\tilde{A} + \tilde{B}K_{r_s(k)}\tilde{C}_{r_s(k)}$  can switch in any of the  $D+1$ -vertices  $A_i = \tilde{A} + \tilde{B}K_i\tilde{C}_i$ , and therefore conditions are sought for the stabilization of the switched system

$$\tilde{x}(k+1) = A_i\tilde{x}(k), \quad i = 0, \dots, D.$$

Under the assumption that at every time instance  $k$  the latency time  $r_s(k)$  can be measured, and therefore the index of the switched-state is known, the system can be described as:

$$x(k+1) = \sum_{i=0}^D \xi_i(k)A_i x(k), \quad (7)$$

where  $\xi(k) = [\xi_0(k), \dots, \xi_D(k)]^T$  and  $\xi = \begin{cases} 1, \text{mode} = A_i \\ 0, \text{mode} \neq A_i \end{cases}$ .

The stability of the switched system [14], in (7) is ensured if  $D+1$  positive definite matrices  $P_i$ ,  $i = 0, \dots, D$  can be found that satisfy the following LMI:

$$\begin{bmatrix} P_i & A_i^T P_j \\ P_j A_i & P_j \end{bmatrix} > 0, \forall (i, j) \in I \times I, \quad (8)$$

$$P_i > 0, \forall i \in I = \{0, 1, \dots, D\}. \quad (9)$$

Based on these  $P_i$ -matrices, it is feasible to calculate a positive Lyapunov function of the form  $V(k, x(k)) = x(k)^T (\sum_{i=0}^D \xi_i(k)P_i)x(k)$  whose difference  $\Delta V(k, x(k)) = V(k+1, x(k+1)) - V(k, x(k))$  is a positive function for all the  $x(k)$ -solutions of the switched system, thus ensuring the asymptotic stability of the system.

### B. Gain Tuning of Output-Feedback Parameters

The computation of the previous output controller  $u(k) = Ky(k - r_s(k))$ , results in a stable system that can tolerate a communication delay of  $D$ -samples ( $r_s(k) \in \{0, 1, \dots, D\}$ ). It should be noted that the controller design procedure was posed in the following manner: a) select the cost-weight matrices  $R$  and  $Q$  and  $\sigma$ -parameter, b) compute  $K$  from the Output-LQR minimization problem, and c) compute the maximum delay  $D$  that can be tolerated with this given gain  $K$ .

In most cases, the communication latency of a typical moNCS does not vary rapidly, and remains within certain bounds over large periods of time, or  $r_s(k) \in \{D_1, \dots, D_2\}$ . In this case, the control design problem can be restated as: At sample period  $k$ , given  $D_1(k)$  and  $D_2(k)$ , compute the weight matrices  $Q(k, R(k))$ , and the prescribed stability factor  $\sigma(k)$  in order to maintain stability in lieu of these communication delays.

Inhere, rather than adjusting in an *ad-hoc* manner the weight matrices, we focus on the  $\sigma(k)$ -quantity. A closed-loop system derived via the usage of a small radius  $\frac{1}{\sigma(k)}$  in the optimization step, has a fast system response, since all of its poles have small magnitude  $|\text{eig}(A + BKC)| \leq \frac{1}{\sigma(k)}$ . However, this system cannot tolerate large delays  $D_2$  and the suggested gain-adjustment relies on this anticipated observation. At the same time, from a performance point of view, we are interested in achieving as fast as possible system response. This requirement conflicts with the need to assure stability despite large communication delays.

The  $\sigma(k)$ -scheduling amounts to computing the smallest value, while at the same time justifying the LMIs of (8),(9) for a given index set  $I = \{D_1, \dots, D_2\}$ . Accordingly, this design philosophy provides the fastest system (largest stability radius) while tolerating these delay bounds. The computation of this optimum  $\sigma(k)$  is based on the following algorithm:

- 1) Start with  $\sigma(k) = 1$ . Compute  $K$  from (2). Check whether the LMIs of (8),(9) are verified. If no, then there is no solution with the given matrices of  $Q$  and  $R$ .
- 2) If yes, then decrease  $\sigma$  by  $\sigma(k) = \sigma(k) - \Delta\sigma$ . Repeat the previous step, unless satisfied with the obtained bound of prescribed stability.

The deliverable, using this tuning scheme is the computation of a set of  $\sigma(k) \rightarrow K(k)$  set of gains that are related to the communication latency bounds  $[D_1(k), D_2(k)]$ .

#### IV. SIMULATION AND EXPERIMENTAL STUDIES

The suggested scheme is applied in a prototype SISO-system implemented using op-amps with a transfer function  $G(s) = \frac{0.1^3}{(s+0.1)^3}$ .

Assuming a sampling period of  $T_s = 5$  second, the discrete equivalent of the continuous system is (accounting for the ZOH)

$$\begin{aligned} x(k+1) &= \begin{bmatrix} 1.8196 & -1.1036 & 0.2231 \\ 1 & 0 & 0 \\ 0 & 1 & 0 \end{bmatrix} x(k) \\ &+ \begin{bmatrix} 1 \\ 0 \\ 0 \end{bmatrix} u(k) \\ y(k) &= [0.0144 \quad 0.0397 \quad 0.0068] x(k) \end{aligned}$$

Assume that a discrete controller  $u(k) = K y(k - r_s(k))$  is inserted in the loop.

##### A. Theoretical Results

In Figure 5, we present the amplitude of the maximum eigenvalue of  $A_{r_s}$  as a function of the time delay  $r_s T_s$  using  $T_s = 5$  seconds, for five different gain values  $K \in \{-1.1927, -1.4439, -1.7225, -3.0933\}$ . These gain values were computed from the minimization of (2) using  $\sigma = 0.98$ ,  $Q = 1$ , and  $R = I_{3 \times 3}$ . As an example we should note for  $K = -3.0933$  ( $-1.4439$ ) the system becomes unstable ( $|\lambda_{\max}(A_{r_s})| \geq 1$ ) for  $r_s T_s \geq 5$  (30) seconds, while for  $K = -1.1927$  the system remains stable for delays smaller than 50 seconds.

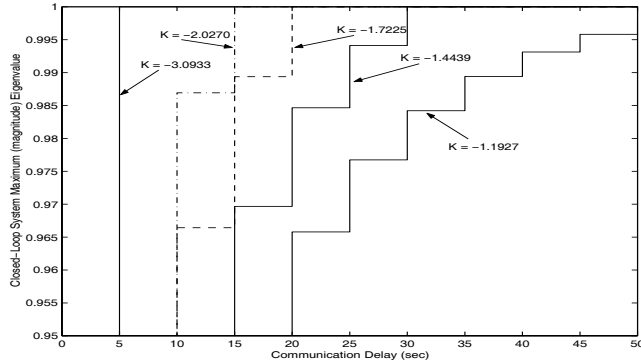

Fig. 5. Stability bounds for discrete controlled TDS ( $T_s=5$ sec)

For the case of time varying delays within subspaces  $I^i = [D_{\min}^i, D_{\max}^i]$ , the problem of computing positive definite matrices in the LMI-related problem in (8) for different  $I^i$ s is sought. If the maximum anticipated delay is  $D \times T_s$  (in our case 50 seconds), then in the ideal case if the problem (8) is solved for  $I^i = [0, D]$ , then the controller can tolerate any delay up to  $D \times T_s$ . In Figure 6 we provide with shaded areas the limits of different  $I^i$  sets for which the LMI-related problem could be solved. As an example for  $T_s = 5$  seconds and  $K = -1.1927$ , the corresponding sets were  $I_D^1 = [0, 30]$ ,  $I_D^2 = [20, 40]$ ,  $I_D^3 = [25, 45]$ , and  $I_D^4 = [40, 50]$ .

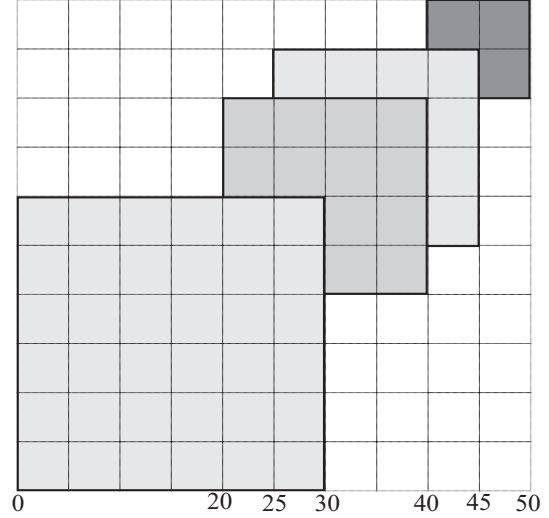

Fig. 6. Stability limits of a Discrete Controlled TDS,  $T_s=5$  sec

It is apparent, that from the LMI-posed problem there exists no controller that can tolerate delays up to 50 seconds. Instead, for  $T_s = 5$  the maximum tolerable latency time is 30 seconds. However, if the latency time varies slowly, then from the overlapping property of these sets, the whole region can be covered. The definition of this “slow-variation is a topic for future research within this overlapping decomposition context. It should be noted, that from the experimental section the observed latency time exhibited a reasonably slow variation and the provided controller proved stable up to a 50-second delay.

##### B. Experimental Results

The suggested controller was applied in experimental studies over a private networks mobile service provider. A GPRS-enabled phone was used for the data transmission, while the necessary interface and drivers were written in National Instruments’ LabView. The software run at the client and server sides on a Pentium system, equipped with proper software to measure the latency time and the transmission speed (NetPerSec by Ziff Davis) in bps achieved during the experimentation.

In Figure 7, we present the measured communication delay  $D_a(k)$  during a typical test-run. The recorded values represent the roundtrip-time for a data packet to transverse between the client and server sides (UDP-time upload + FTP-time download); these values were recorded with an accuracy of 200 msec. The mean value of this delay is 12.7 sec and does not exceed the anticipated limit of 50 sec.

The controller, subsequently, adjusts its feedback-gain based on the quantized (with a  $T_s=5$  sec resolution) ceiling function of the actual communication delay  $D_c(k) = \lceil \frac{D_a(k)}{T_s} \rceil$ . To accommodate, variations on the communication latency, the controller uses at time  $k$ , the following values  $[D_{\min}(k), D_{\max}(k)] = [D_c - 1(k), D_c + 1(k)]$ .

In Figure 8, we present the response of the system when

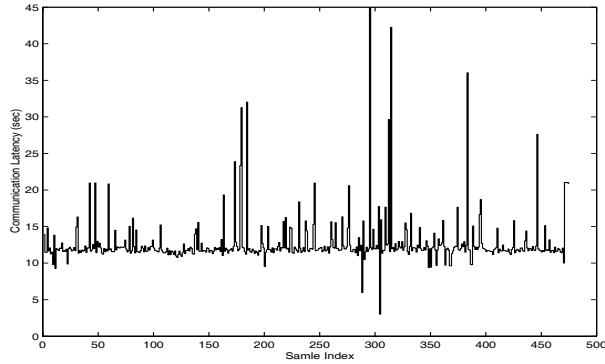

Fig. 7. Measured Communication Latency

excited with a pulsing reference signal. The control signal is presented in Figure 9, where the effects of the time delays are eminent. For the packet-loss cases, or when there is a temporary malfunction in the communication link and the server does not accept data through the UDP port, the last recorded control command is transmitted to the plant.

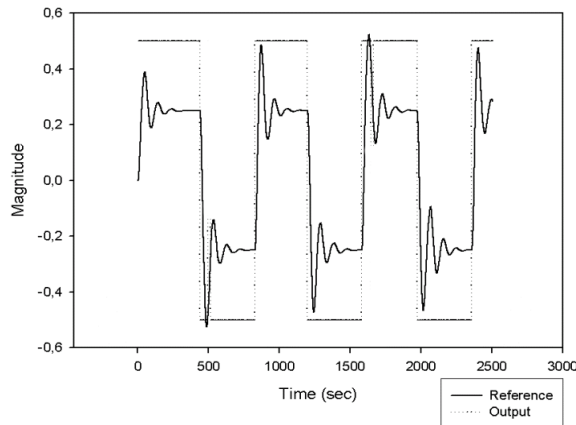

Fig. 8. Mobile (GPRS-based) NCS Response

## V. CONCLUSIONS

In this paper the development and experimental verification of a mobile client-centric networked controlled system was presented. The designed controller needs to accommodate the embedded transmission delays due to the packet exchange between the two sides (client-server). The resulting controller relies on a gain-scheduling framework; the controller structure stems from the LQR-output feedback case, where the prescribed stability factor is tuned according to the measured communication delay. The robustness of the suggested scheme is investigated through the use of LMI-theory. Experimental results are offered to investigate the efficiency of the proposed scheme.

## VI. ACKNOWLEDGMENTS

The authors wish to express their gratitude towards Vodafone-Panafon, a mobile-service provider, located in

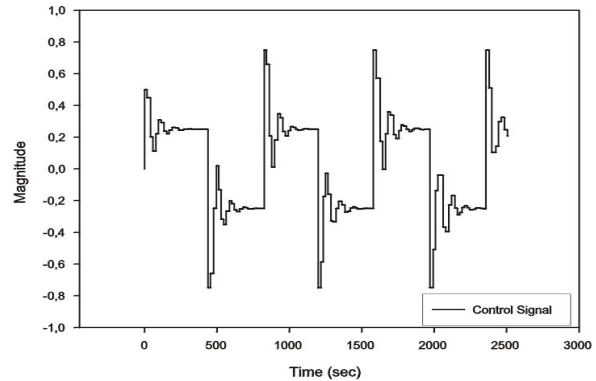

Fig. 9. Mobile (GPRS-based) NCS Control Signal

Greece, for its active assistance in the experimental section.

## REFERENCES

- [1] A. Tzes, G. Nikolakopoulos, and I. Koutroulis, "Development and experimental verification of a mobile client-centric networked controlled system," in *Proceedings of the European Control Conference*, no. 113, Cambridge, UK, Sept. 2003, (this article received the IST-prize award from EU in 2003).
- [2] J. Overstreet and A. Tzes, "An Internet-Based Real Time Control Engineering Laboratory," *IEEE Control Systems Magazine*, vol. 99, pp. 19–34, Oct. 1999.
- [3] Y. Halevi and A. Ray, "Integrated communication and control systems: Part I - analysis," *Transactions of the ASME, Journal of Dynamic Systems, Measurement and Control*, vol. 110, pp. 367–373, December 1988.
- [4] A. Ray and Y. Halevi, "Integrated communication and control systems: Part II - design considerations," *Transactions of the ASME, Journal of Dynamic Systems, Measurement and Control*, vol. 110, pp. 374–381, Dec 1988.
- [5] F. Lian, J. Moyné, and D. Tilbury, "Network Design Consideration for Distributed Control Systems," *IEEE Transactions on Control Systems Technology*, vol. 10, no. 2, pp. 297–307, March 2002.
- [6] M. Branicky, S. Phillips, and W. Zhang, "Stability of networked control systems: explicit analysis of delay," *Proceedings of the American Control Conference*, pp. 2352–2357, June 2000.
- [7] G. Walsh, H. Ye, and L. Bushnell, "Stability Analysis of Networked Control Systems," *IEEE Transactions on Control Systems Technology*, vol. 10, no. 3, pp. 438–446, May 2002.
- [8] The Mathworks, Partner, and Series, "LMI control toolbox," 2000.
- [9] S. Boyd, V. Balakrishnan, E. Feron, and L. Ghaoui, "Control system analysis and synthesis via linear matrix inequalities," in *Proceedings of the American Control Conference*, June 1993.
- [10] C. Networking, *IP Tutorial: User Datagram Protocol (UDP)*.
- [11] A. Weinmann, *Uncertain Models and Robust Control*. New York: Springer Verlag, 1991.
- [12] L. Liou and A. Ray, "Integrated Communication and Control Systems: Part III - Nonidentical Sensor and Controller Sampling," *Transactions of the ASME, Journal of Dynamic Systems, Measurement and Control*, vol. 112, pp. 357–364, September 1990.
- [13] S. Ge, Z. Sun, and T. Lee, "Reachability and controllability of switched linear discrete-time systems," *IEEE Transactions on Automatic Control*, vol. 46, no. 9, Sept 2001.
- [14] M. S. Mahmoud, "Robust control and filtering for time delay systems," *Marcel Dekker Inc.*, Jan 2000.