

Modeling and Adaptive Control of a Coordinate Measuring Machine

Â. Yurdun Orbak, *Member, IEEE*

Abstract— Although traditional measuring instruments can provide excellent solutions for the measurement of length, height, inside and outside diameters, etc., a coordinate measurement machine (CMM), at least in principle, can combine all these requirements in a single versatile instrument. As they can also be fully automated, linked to a CAD system and/or built into the flexible manufacturing cell, CMMs are widely used in today's industry. The aim of this paper is to design a stable controller for a 3D coordinate measuring machine in the presence of uncertainties and unknown disturbances. To achieve this task, first a simplified model of the CMM will be obtained. After this modeling step, different types of adaptive control techniques are applied to get a suitable and efficient control system. The results are discussed in detail in order to give insight to some common problems in controlling CMMs.

I. INTRODUCTION

THE main goal of this paper is to design a stable controller for a 3D coordinate measuring machine (CMM) in the presence of uncertainties and unknown disturbances [9, 11, 13]. The design of the CMM is similar to some of the machine tools like CNC's with the difference being the presence of extra control inputs [1, 2, 3]. The presence of these extra controls simplifies the problem and we could formulate it into a multi-input robotic control problem as discussed in [14]. The controller used is an adaptive one with the nonlinearities and the disturbances being lumped into just a single bounded term. In [14], problems of these types have been considered in a systematic way quite extensively when all the states are available for feedback. The structure of this controller has the advantage that, apart from giving good performance in tracking in spite of the presence of unknown disturbances and uncertainties, it also gives a robustly stable algorithm.

As opposed to the CNC machines, the CMM problem is different in the sense that there are lesser number of control inputs. Thus, a full-state feedback adaptive controller is used to a linearized model of the CMM.

If all the states are not available for feedback, then in general it is quite complicated to build an observer for a

nonlinear system. However, in our case the system equations are linearized (except for the disturbance term) and we can therefore have an adaptive observer to estimate the unknown states (using an MRAC formulation). Using these estimates, one can then use essentially a similar controller structure as done when all the states are available for feedback. This constitutes some of the future work that needs to be accomplished.

In the following sections, first the modeling of a CMM is performed. Then the control methodologies discussed above will be illustrated. The simulation results indicate that the controllers perform very well.

II. MODELING OF THE COORDINATE MEASURING MACHINE

The schematic diagram of the coordinate measuring machine is shown in Figure 1. Writing the mathematical model of the 3D model shown will be too cumbersome with very little benefit, if only we could get a simpler model that describes the essential features fairly accurately [1, 4, 8]. Since the arms of the CMM are supported on air bearings, the damping is reduced considerably. From the diagram and from the actual machine one observes that the dynamics in the y and z directions are negligible compared to that of x direction at least as a reasonable first approximation (this can be verified by getting the bode magnitude plot from the input of the motor on the y -axis to the measurement on the linear encoder on the x -axis which would be much below the 0 dB line).

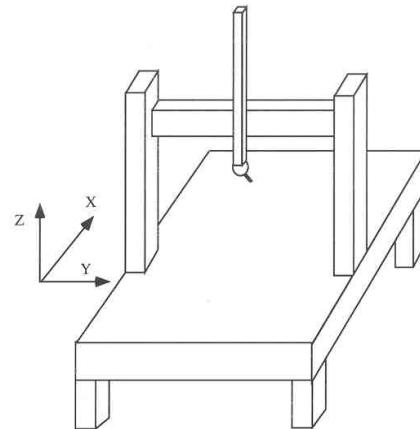

Fig. 1. Schematic diagram of CMM.

The transmission of the torque from the motor to the machine is through a belt drive, which can be approximated as a spring with a damper. This is a good approximation at low frequencies while at high frequencies the above-approximated stiffness of the belt in the longitudinal direction is less compared to the one that is perpendicular to this direction. This stiffness in the perpendicular direction is nonlinear and is not easy to model.

On the other hand, the bandwidth of the machine is reasonably small (≈ 15 Hz) that this unmodeled nonlinear stiffness can be approximated as a bounded disturbance. Notice further that because of the large gear reduction, the nonlinearities and other unmodeled effects are largely diminished on the motor side.

With all the above-mentioned realistic assumptions the coordinate measuring machine can be modeled as a two-dimensional model. For this system, the main objective is to design a stable control algorithm to control the position of the tip of the coordinate measuring machine (CMM) and to track a specified trajectory despite the presence of unknown but bounded disturbances and parameter uncertainties. The approach taken for the solution of this problem is that of a robust adaptive sliding control technique [14].

III. DESCRIPTION OF THE MODEL

As mentioned in the previous section, the coordinate measuring machine is modeled as a simplified two-dimensional model as shown in the Figure 2. In this model the z -axis is completely eliminated and it is represented on the x - y plane as masses M and m . The distance l_a of the mass m is a parameter of the problem and there is no dynamics involved along the y direction due to this mass m . However, note that both the inertia and the location of the center of mass of the combined system (including M and m) changes if l_a is changed. Therefore, it is concluded that l_a has significant effect on the dynamics of the system.

The springs k_1 and k_2 represent the belts of the CMM. The mass m is attached to the rigid body M that is free to translate and rotate about its center of mass.

The force F at Q as shown in the figure represents the actuator. The linear encoders are present at A and at B . There is also a rotary encoder on the motor, which when translated into this model's representation gives the measurement x_3 . This encoder is a collocated sensor while the linear encoder at either A or B is a noncollocated sensor.

In formulating the equations of the model, the following assumptions are made:

- The angle of rotation θ of the mass about the center of mass is small so that $\sin \theta \approx \theta$ and $\cos \theta \approx 1$.
- The actuator moves horizontally and does not rotate. The input to the system is the force F applied on the actuator.

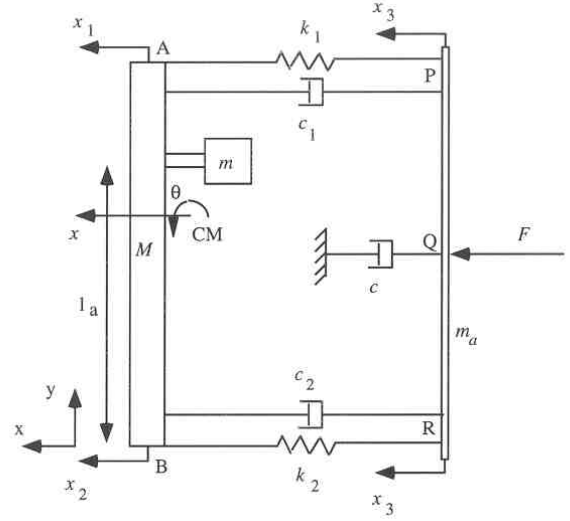

Fig. 2. Two-dimensional model of a CMM with the force F acting at Q .

The case in which the spring constants k_1 and k_2 are not necessarily equal is considered. The number of degrees of freedom for this system is three and the generalized coordinates can be taken as x , θ and x_3 (or equivalently x_1 , x_2 and x_3).

The equations of motion for the system shown in Figure 2 can be written from the Lagrangian (or from Newton's laws) as

$$\begin{aligned}
 (M + m)\ddot{x} + (c_1 + c_2)\dot{x} + (k_1 + k_2)x + (c_1l_1 - c_2l_2)\dot{\theta} + \\
 + (k_1l_1 - k_2l_2)\theta = (c_1 + c_2)\dot{x}_3 + (k_1 + k_2)x_3 + \tau_1 \\
 I_{CM}\ddot{\theta} + (c_1l_1^2 + c_2l_2^2)\dot{\theta} + (k_1l_1^2 + k_2l_2^2)\theta + (c_1l_1 - c_2l_2)\dot{x} + \\
 + (k_1l_1 - k_2l_2)x = (c_1l_1 - c_2l_2)\dot{x}_3 + (k_1l_1 - k_2l_2)x_3 + \tau_2 \\
 m_a\ddot{x}_3 = \tau_3 - (M + m)\ddot{x} - c\dot{x}_3
 \end{aligned} \quad (1)$$

The unknown parameters for this system are the coefficients of the states and their derivatives. The following are the parameters defined in the present situation:

$$\begin{aligned}
 a_1 = I_{CM} & & a_6 = k_1 + k_2 \\
 a_2 = c_1 + c_2 & & a_7 = k_1l_1 - k_2l_2 \\
 a_3 = c_1l_1 - c_2l_2 & & a_8 = k_1l_1^2 + k_2l_2^2 \\
 a_4 = c_1l_1^2 + c_2l_2^2 & & a_9 = M + m \\
 a_5 = c_1 + c_2 + c & & a_{10} = m_a
 \end{aligned} \quad (2)$$

One can also represent (1) in the standard form as

$$\mathbf{H}\ddot{\mathbf{q}} + \mathbf{C}\dot{\mathbf{q}} + \mathbf{K}\mathbf{q} = \boldsymbol{\tau} \quad (3)$$

where

$$\begin{aligned}
 \mathbf{H} = \text{diag}([M + m \quad I_{CM} \quad m_a]) \\
 \mathbf{C} = \begin{pmatrix} c_1 + c_2 & c_1l_1 - c_2l_2 & -c_1 - c_2 \\ c_1l_1 - c_2l_2 & c_1l_1^2 + c_2l_2^2 & -c_1l_1 + c_2l_2 \\ -c_1 - c_2 & -c_1l_1 + c_2l_2 & c_1 + c_2 + c \end{pmatrix}
 \end{aligned} \quad (4)$$

and

$$\mathbf{K} = \begin{pmatrix} k_1 + k_2 & k_1 l_1 - k_2 l_2 & -k_1 - k_2 \\ k_1 l_1 - k_2 l_2 & k_1 l_1^2 + k_2 l_2^2 & -k_1 l_1 + k_2 l_2 \\ -k_1 - k_2 & -k_1 l_1 + k_2 l_2 & k_1 + k_2 \end{pmatrix}, \boldsymbol{\tau} = \begin{pmatrix} \tau_1 \\ \tau_2 \\ \tau_3 \end{pmatrix} \quad (5)$$

Here the position vector q is defined as $q = [x \ \theta \ x_3]^T$.

The nonlinear stiffness and the disturbances are lumped into a single term and are represented as a bounded function $\mathbf{d}(q, \dot{q}, t)$ and the corresponding equation of motion is modified as

$$\mathbf{H}\ddot{q} + \mathbf{C}\dot{q} + \mathbf{K}q = \boldsymbol{\tau} + \mathbf{d}(q, \dot{q}, t) \quad (6)$$

where $\|\mathbf{d}(q, \dot{q}, t)\|_2 \leq D$.

In this paper, the goal, as mentioned earlier, is to design a stable controller that tracks a desired trajectory q_d for the system represented by (3) and (6) for both the multi-input and single-input cases. These issues are discussed in the following sections in detail.

IV. CONTROL PROBLEM

First a stable adaptive controller (see [14] for example) that does perfect tracking for the system given by (3) when all the three control inputs are present and there is no disturbance will be designed. Then, the adaptive law will be modified to control the system given by (6), which will include disturbance terms. However, in this case it will be seen that perfect tracking is not achieved and there will be a dead zone due to the bounded disturbance. The above two methods are also useful in the case of CNC machines where there are typically many inputs. On the other hand, for the coordinate measuring machine there is only one input at x_3 as shown in Figure 2. For these types of systems a sliding adaptive control technique is generally used. In the following subsections each of these approaches will be discussed in greater detail.

A. Full State Feedback Multi-Input Control in the Absence of Disturbances

Let q_d be the desired trajectory that we wish to track and q_r be the reference signal vector. Then the error is given by $\tilde{q} = q - q_d$. By letting λ as an positive constant, a surface $s = s(t)$ can be defined as $s = \tilde{q} + \lambda \dot{\tilde{q}} = \dot{q} - \dot{q}_r$. Here $\dot{q}_r = \dot{q}_d - \lambda \tilde{q}$ is taken. Then $\dot{s} = \ddot{q} - \ddot{q}_r$. Now, let's choose a Lyapunov function candidate V as

$$V = \frac{1}{2} s^T \mathbf{H} s + \frac{1}{2} \tilde{a}^T \boldsymbol{\Gamma}^{-1} \tilde{a} \quad (7)$$

where $\tilde{a} = \hat{a} - a$ is the parameter error, \hat{a} is the estimate of the true parameter a , and $\boldsymbol{\Gamma}$ is a positive definite matrix. Then

$$\begin{aligned} \dot{V} &= s^T \mathbf{H} \dot{s} + \dot{\hat{a}}^T \boldsymbol{\Gamma}^{-1} \tilde{a} \\ &= s^T (\mathbf{H}\ddot{q} - \mathbf{H}\ddot{q}_r) + \dot{\hat{a}}^T \boldsymbol{\Gamma}^{-1} \tilde{a} \\ &= s^T (\boldsymbol{\tau} - \mathbf{H}\ddot{q}_r - \mathbf{C}\dot{q} - \mathbf{K}q) + \dot{\hat{a}}^T \boldsymbol{\Gamma}^{-1} \tilde{a} \end{aligned} \quad (8)$$

Now let's choose the control law as $\boldsymbol{\tau} = \hat{\mathbf{H}}\ddot{q}_r + \hat{\mathbf{C}}\dot{q} + \hat{\mathbf{K}}q - \mathbf{K}_d s$ where $\hat{\mathbf{H}}$, $\hat{\mathbf{C}}$, and $\hat{\mathbf{K}}$ correspond to the estimates of the true values of \mathbf{H} , \mathbf{C} and \mathbf{K} respectively, which constitute the parameters of our system, and \mathbf{K}_d is a positive definite matrix. In addition to the control law if one defines a \mathbf{Y} according to

$$\mathbf{H}\ddot{q} + \mathbf{C}\dot{q} + \mathbf{K}q = \mathbf{Y}a \quad (9)$$

one then obtains

$$\hat{\mathbf{H}}\ddot{q} + \hat{\mathbf{C}}\dot{q} + \hat{\mathbf{K}}q = \mathbf{Y}\hat{a} \quad (10)$$

As a result,

$$\Rightarrow \dot{V} = s^T (\mathbf{Y}\tilde{a} - \mathbf{K}_d s) + \dot{\hat{a}}^T \boldsymbol{\Gamma}^{-1} \tilde{a} \quad (11)$$

If the adaptation law is chosen as $\dot{\hat{a}} = -\boldsymbol{\Gamma}\mathbf{Y}^T s$, this implies that

$$\dot{V} = -s^T \mathbf{K}_d s \leq 0 \quad (12)$$

Now

$$\ddot{V} = -2s^T \mathbf{K}_d \dot{s} \quad (13)$$

is bounded because s and \tilde{a} are bounded. Note that $\dot{s} = \mathbf{H}^{-1}(\mathbf{Y}\tilde{a} - \mathbf{K}_d s)$ (compare (8) and (11)) is also bounded. Therefore, $V \geq 0$, $\dot{V} \leq 0$ and \ddot{V} is bounded implies that $\dot{V} \rightarrow 0$ as $t \rightarrow \infty$ from Barbalat's lemma.

Therefore $s \rightarrow 0$ since \mathbf{K}_d is positive definite, which implies that $\tilde{x} \rightarrow 0$ as $t \rightarrow \infty$, i.e., perfect tracking is achieved. In other words, in the absence of any disturbances, perfect tracking is achieved with the above choice of control and adaptive laws.

The simulation results that illustrate the above theoretical results are described next.

The values of the various parameters of the model are tabulated in Table 1.

TABLE I
PARAMETER VALUES FOR SIMULATION

l_a	0.4 m	c	50 N·s/m
L	1.5 m	c_1	50 N·s/m
M	200 kg	c_2	45 N·s/m
m	100 kg	k_1	2000 N/m
m_a	50 kg	k_2	1500 N/m

The controller is without the bounded disturbance. Therefore, the control and the adaptive laws mentioned earlier are used in the simulations. The results are shown in Figures 3 through 5. The desired trajectory chosen was $q_d = (\sin 4t \ 0 \ \sin 3t)^T$, and the other parameters used in the simulations were $\boldsymbol{\Gamma} = \text{diag}([10, 2, 4, 5, 5, 2, 9, 7, 10, 11])$, $\lambda = 50$, and $\mathbf{K}_d = \text{diag}([20, 20, 20])$. Notice that there is very good tracking by the above choice of control and adaptive laws in all states. And the control input required to achieve good tracking is quite high. The parameters do not converge to their true values as expected because the input is not sufficiently rich or persistently exciting.

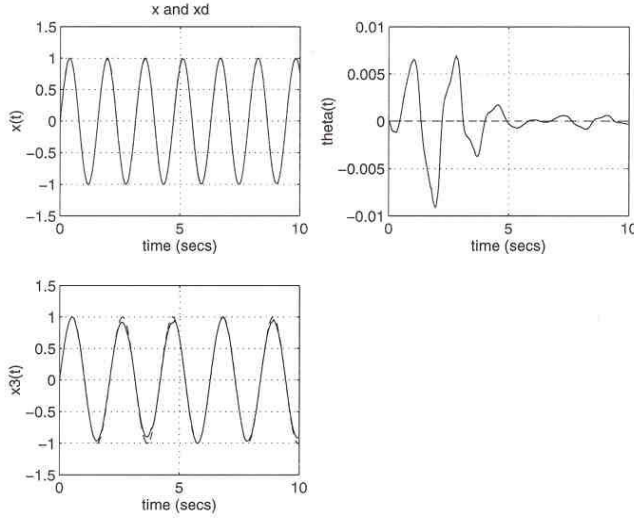

Fig. 3. Comparison of states (no disturbance).

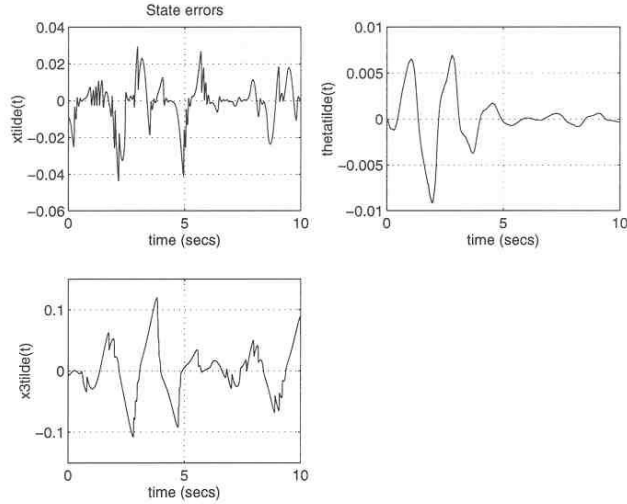

Fig. 4. Error in tracking (no disturbance).

In the following subsection, a stable controller is designed for the case with bounded disturbances.

B. Full State Feedback Multi-Input Control in the Presence of Disturbance

The approach taken is similar to the previous case except that the Lyapunov function candidate is chosen as

$$V = \frac{1}{2} s_{\Delta}^T \mathbf{H} s_{\Delta} + \frac{1}{2} \tilde{a}^T \mathbf{\Gamma}^{-1} \tilde{a} \quad (14)$$

where

$$s_{\Delta} = s - \phi \text{sat}\left(\frac{s}{\phi}\right) \quad (15)$$

with saturation function $\text{sat}(\cdot)$ defined component wise. Here ϕ is a positive scalar. Then

$$\begin{aligned} \dot{V} &= s_{\Delta}^T \mathbf{H} \dot{s} + \dot{\tilde{a}}^T \mathbf{\Gamma}^{-1} \tilde{a} \\ &= s_{\Delta}^T (\mathbf{H} \ddot{q} - \mathbf{H} \ddot{q}_r) + \dot{\tilde{a}}^T \mathbf{\Gamma}^{-1} \tilde{a} \\ &= s_{\Delta}^T (\boldsymbol{\tau} + \mathbf{d} - \mathbf{H} \ddot{q}_r - \mathbf{C} \dot{q} - \mathbf{K} q) + \dot{\tilde{a}}^T \mathbf{\Gamma}^{-1} \tilde{a} \end{aligned} \quad (16)$$

The control and the adaptation laws are chosen as $\boldsymbol{\tau} = \mathbf{Y} \hat{a} - \mathbf{K}_d s$ and $\dot{\hat{a}} = -\mathbf{\Gamma} \mathbf{Y}^T s_{\Delta}$, respectively where \mathbf{Y} is defined as before in (9).

Then,

$$\dot{V} = -s_{\Delta}^T \mathbf{K}_d s_{\Delta} + s_{\Delta}^T \left[\mathbf{d} - \mathbf{K}_d \phi \text{sat}\left(\frac{s}{\phi}\right) \right] \quad (17)$$

If one chooses $\mathbf{K}_d = k_d \mathbf{I}$ and define $\text{sgn}(s)$ as a vector of the signs of the individual components, he/she obtains,

$$\dot{V} \leq -s_{\Delta}^T k_d s_{\Delta} \leq 0 \quad (18)$$

Here the following are used: (i) the 1-norm of a vector is the sum of the absolute values of its components, and (ii) the 2-norm is the standard Euclidean norm.

As in the previous section, one can observe that

$$\ddot{V} \leq -2s_{\Delta} k_d \dot{s} \quad (19)$$

is bounded since s_{Δ} and \tilde{a} are bounded. Note that $\dot{s} = \mathbf{H}^{-1}(\mathbf{Y} \tilde{a} - \mathbf{K}_d s + \mathbf{d})$ is also bounded. Therefore, $V \geq 0$, $\dot{V} \leq 0$ and \ddot{V} is bounded implies that $\dot{V} \rightarrow 0$ as $t \rightarrow \infty$ from Barbalat's lemma.

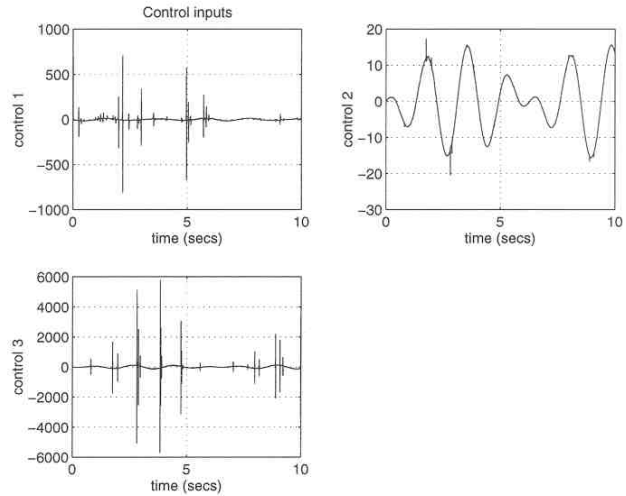

Fig. 5. Control inputs (no disturbance).

Since \mathbf{K}_d is positive definite, one sees that from s_{Δ} , $|s| \leq \phi$. This implies that $|\tilde{x}| \leq \phi / \lambda^{n-1}$ as $t \rightarrow \infty$, i.e., a dead zone in adaptation and hence in tracking is present.

The simulation results with bounded disturbance are as shown in Figures 6 through 8. The parameters used in these simulations are the same as before except that the bound on the disturbance is chosen as $D = 10$. Furthermore, ϕ is chosen such that $k_d \phi = D$. Notice the increase in errors compared to the case with no disturbance.

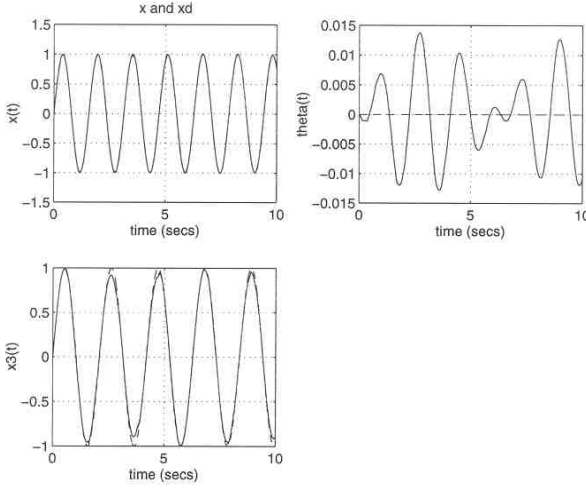

Fig. 6. Comparison of states (with disturbance).

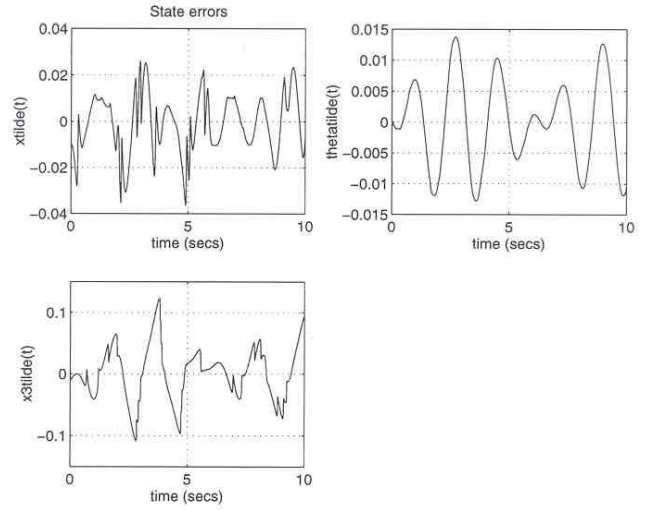

Fig. 7. Error in tracking (with disturbance).

C. Full State Feedback Single-Input Adaptive Control

Now let's turn to the question of controlling the CMM when there is only one input F as shown in Figure 2. The equations of motion are essentially the same as (1) except that τ_1 and τ_2 are zero and $\tau_3=F$.

As before, it is assumed that full state is available for feedback. The output of interest is x in this case. The additional assumption that simplifies the control structure design is when the transfer function from the input F to the output x is minimum phase. It is observed that with the nominal values chosen as given in Table 1, this minimum phase assumption is satisfied.

The relative order of the transfer function from F to x is three (six poles and three zeros). Thus an approach similar to input-output feedback linearization can be used to express the states as the output and its derivatives. Since the relative order is three, it is seen that the output x needs to be differentiated three times to see the control input in the state equation.

The task then is to design a stable adaptive controller for this third order system with the states x , \dot{x} and \ddot{x} and the minimum phaseness will guarantee global asymptotic stability of the internal dynamics which consists of the other three states.

The approach taken is again the one described in [14]. The state equations are given in the companion form as

$$h\ddot{x} + \sum_{i=1}^5 a_i f_i = u \quad (20)$$

Differentiating the first equation (having \ddot{x}) in (1) and substituting for $\ddot{\theta}$ and \ddot{x}_3 from the remaining two equations, one observes that the control input appears in this equation and can therefore be expressed in the form given in (20) for suitable values of h , a_i 's and f_i . Here, $u = F$, is the control input.

Define $e = x - x_d$ and

$$s = \ddot{e} + 2\lambda\dot{e} + \lambda^2 e = \ddot{x} - \ddot{x}_r \quad (21)$$

where $\ddot{x}_r = \ddot{x}_d - 2\lambda\dot{e} - \lambda^2 e$. Now,

$$hs = h\ddot{x} - h\ddot{x}_r = u - \sum_{i=1}^5 a_i f_i - h\ddot{x}_r \quad (22)$$

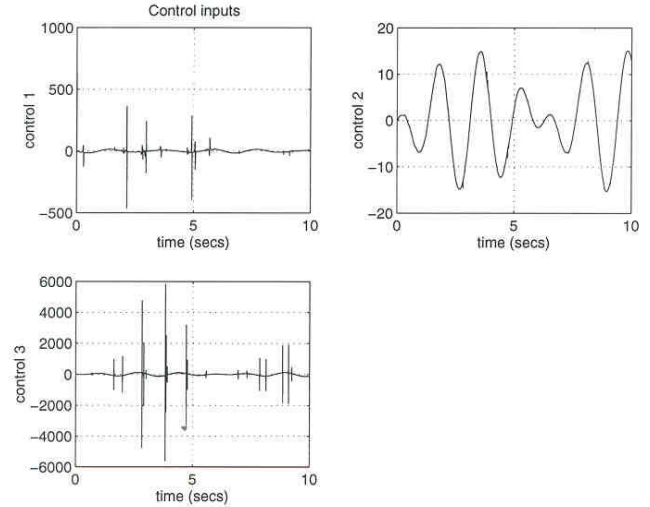

Fig. 8. Control inputs (with disturbance).

If all the parameters are known, then one can choose a control law that gives a guaranteed convergence of s by defining u as

$$u = \sum_{i=1}^5 a_i f_i + h\ddot{x}_r - ks \quad (23)$$

This choice of control leads to the tracking error dynamics to $hs + ks = 0$. For the adaptive control, the control law is chosen as $u = \sum_{i=1}^5 \hat{a}_i f_i + \hat{h}\ddot{x}_r - ks$ where \hat{a}_i and \hat{h} are the

estimates of the true parameters. The tracking error then becomes

$$h\dot{s} + ks = \sum_{i=1}^5 \tilde{a}_i f_i + \tilde{h}\ddot{x}_r \quad (24)$$

$$s = \frac{1/h}{p + k/h} \left[\sum_{i=1}^5 \tilde{a}_i f_i + \tilde{h}\ddot{x}_r \right] \quad (25)$$

Now by using Lemma 8.1 of [14], the adaptation law is:

$$\begin{aligned} \dot{\hat{h}} &= -\gamma \operatorname{sgn}(h) s \ddot{x}_r \\ \dot{\hat{a}}_i &= -\gamma \operatorname{sgn}(h) s f_i \end{aligned} \quad (26)$$

This is obtained by taking the Lyapunov function candidate as

$$V = \frac{1}{2} |h| s^2 + \frac{1}{2} \gamma^{-1} \left[\tilde{h}^2 + \sum_{i=1}^5 \tilde{a}_i^2 \right] \quad (27)$$

This then gives $\dot{V} = -|k|s^2$. This choice of control and adaptive laws give global tracking convergence.

The simulation results are shown in Figures 9 and 10. The gains for very good tracking are very high compared to the multi-input case and therefore the control inputs are also high. The desired trajectory chosen is $x_d = \sin^2(t)$.

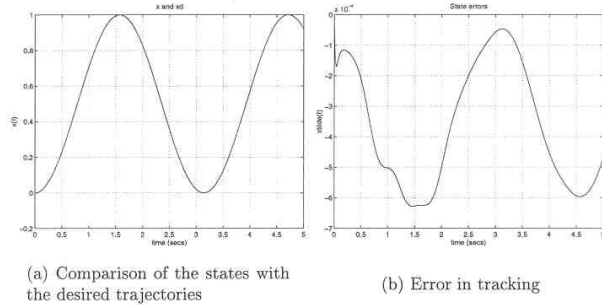

Fig. 9. States and their errors.

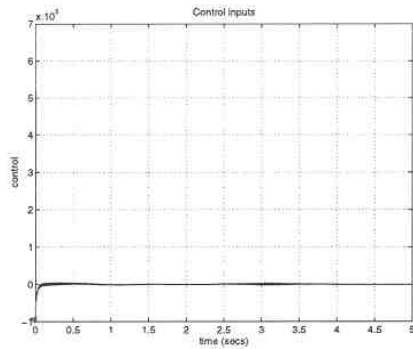

Fig. 10. Control inputs.

V. CONCLUSIONS

In this paper, first the modeling of a coordinate measuring machine is considered and it is assumed that all the states are available for feedback. With this assumption an adaptive controller based on sliding control architecture

is designed for the multi-input case as described in [14]. After this step, a robust controller in the presence of disturbances is designed. It is observed that the performance slightly diminishes in the second case. However, the controller assures robust stability.

The simulations also indicate that when there is only one single input in the control structure, the performance is good only at the expense of very large control input signals.

REFERENCES

- [1] Y. Shen and X. Zhang, "Modeling of Pretravel for Touch Trigger Probes on Indexable Probe Heads on Coordinate Measuring Machines," *International Journal of Advanced Manufacturing Technology*, Vol. 13/4, pp. 206-213, April 1997.
- [2] G. Lee, J. Mou, and Y. Shen, "Sampling Strategy Design for Dimensional Measurement of Geometric Features using Coordinate Measuring Machines," *International Journal of Machine Tools and Manufacture*, Vol. 37, No. 3, pp. 263-276, 1997.
- [3] Y. Shen, "Automated Dimensional Inspection Using Coordinate Measuring Machines," *Proceedings of the 1993 US/Taiwan Joint Automation and Productivity Workshop*, pp. 10.1-10.12, Taipei, Taiwan, July 1993.
- [4] Y. Shen, "Computer-Integrated Dimensional Inspection Using Coordinate Measuring Machines," *Proceedings of International Conference on Technology Transfer and Comparative Management*, pp. 73-77, Los Angeles, CA., August 1993.
- [5] Y. Shen and X. Zhang, "Uncertainty Assessment in Measurement Results Using Coordinate Measurement Systems," *Proceedings of 1995 International Mechanical Engineering Congress and Exposition*, San Francisco, CA, November 1995.
- [6] T.-Z. Shen and C.-H. Menq, "Automatic camera calibration for a multiple-sensor integrated coordinate measurement system," *IEEE Transactions on Robotics and Automation*, Vol. 17, No. 4, pp. 502-507, August 2001.
- [7] F. Prieto, T. Redarce, P. Boulanger, and R. Lepage, "Tolerance control with high resolution 3D measurements," *Proceedings of Third International Conference on 3-D Digital Imaging and Modeling*, pp. 339-346, 2001.
- [8] L. Dejun, C. Rensheng, L. Zifang, and L. Xiaochuan, "Research on the theory and the virtual prototype of 3-DOF parallel-link coordinate-measuring machine," *Proceedings of the 18th IEEE Instrumentation and Measurement Technology Conference, IMTC 2001*, Vol. 2, pp. 926-930, 2001.
- [9] S. N. Spitz and A. A. G. Requicha, "Multiple-goals path planning for coordinate measuring machines," *Proceedings of IEEE International Conference on Robotics and Automation, ICRA '00*, Vol. 3, pp. 2322-2327, 2000.
- [10] S. N. Spitz, A. J. Spyridi, and A. A. G. Requicha, "Accessibility analysis for planning of dimensional inspection with coordinate measuring machines," *IEEE Transactions on Robotics and Automation*, Vol. 15, No. 4, pp. 714-727, August 1999.
- [11] A. Limaïem and H. A. Elmaraghy, "Automatic path planning for coordinate measuring machines," *Proceedings of IEEE International Conference on Robotics and Automation*, Vol. 1, pp. 887-892, 1998.
- [12] H. Zhuang and Y. Wang, "A coordinate measuring machine with parallel mechanisms," *Proceedings of IEEE International Conference on Robotics and Automation*, Vol. 4, pp. 3256-3261, 1997.
- [13] M. R. Katebi, T. Lee, and M. J. Grimble, "Total control of fast coordinate measuring machines," *IEE Proceedings on Control Theory and Applications*, Vol. 141, No. 6, pp. 373-384, November 1994.
- [14] J.-J. Slotine and W. Li, *Applied Nonlinear Control*, Prentice Hall, Inc. Englewood Cliffs, New Jersey 07632, 1991.