

# Practical process control

## Examples from a chemical industry

Krister Forsman  
2017-11-08



# Typical tasks for the control group

- Improve productivity by decreased variation and increased automation.
  - Smarter control structures, e.g. feedforwards, mid-ranging, split range, cascades, maximizing control, ratio-in-cascade
  - PID control parameter tuning
  - Plant-wide control issues
  - Introduce new controllers
  - Support in design and commissioning of new plants
- Process historian (database) ownership; applications and development in Industrial ICT
- Training seminars

# Tools are centered around Matlab

- The most important tools in the optimization work is Matlab and IP21.
- We have developed our own libraries for
  - Data collection from IP21
  - Data analysis
  - Simulation of controllers and control structures
  - Identification
  - Assessment of control performance
  
- Some examples of tools below

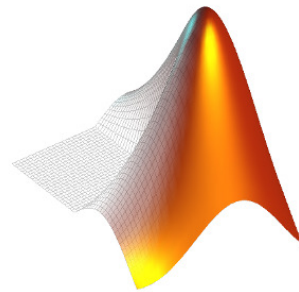

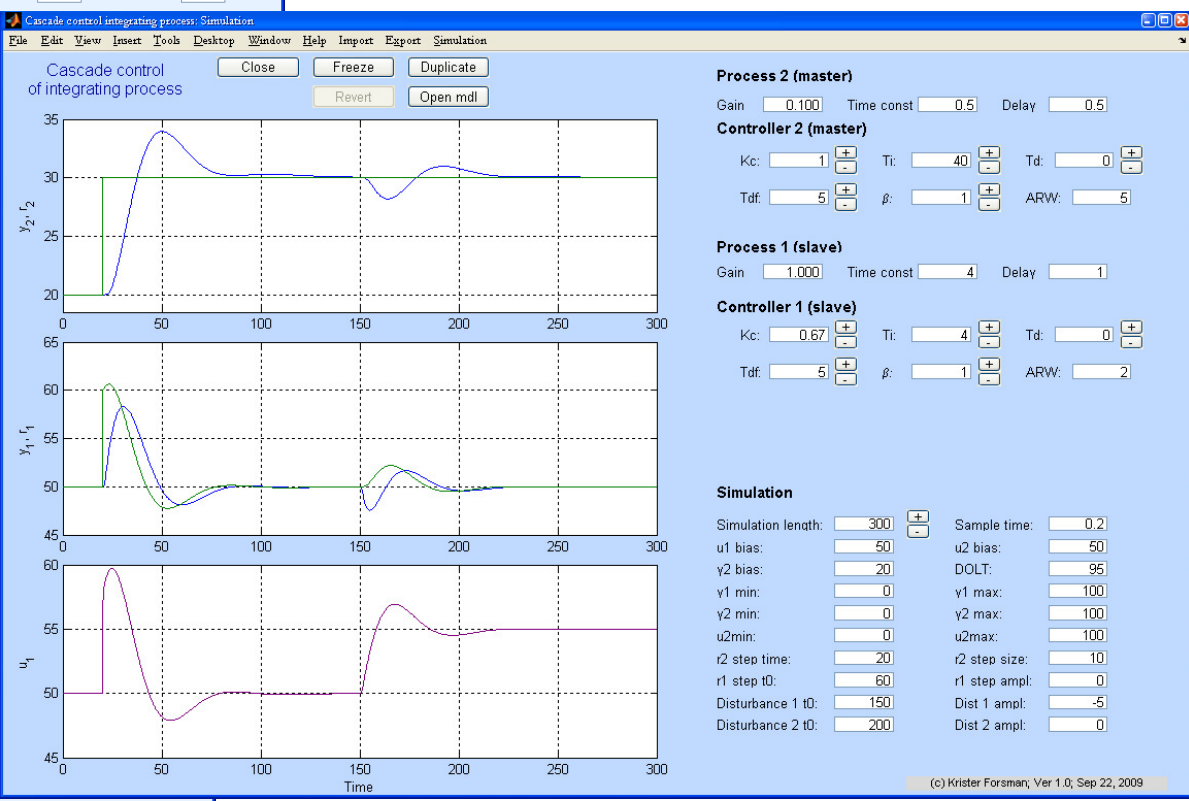
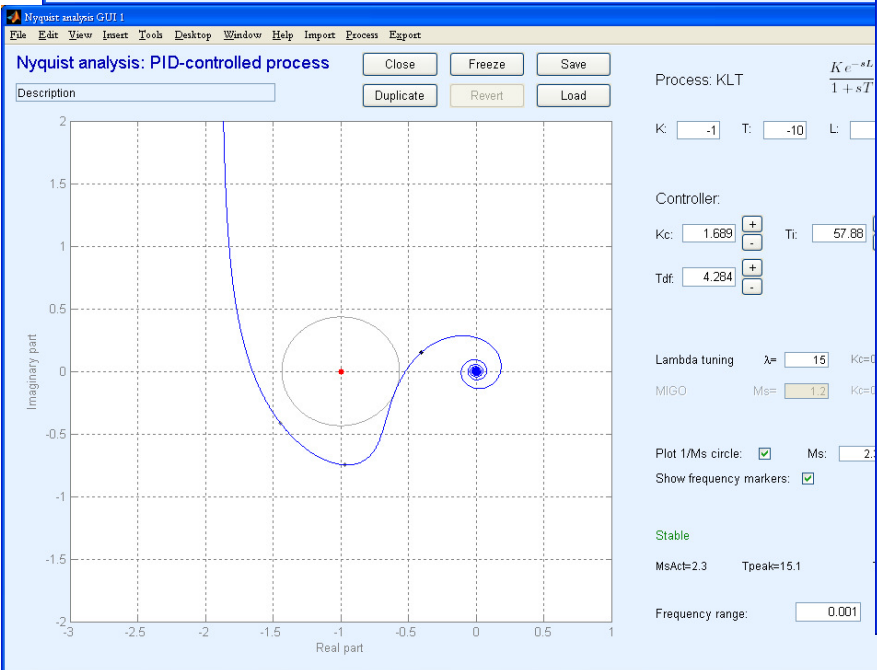
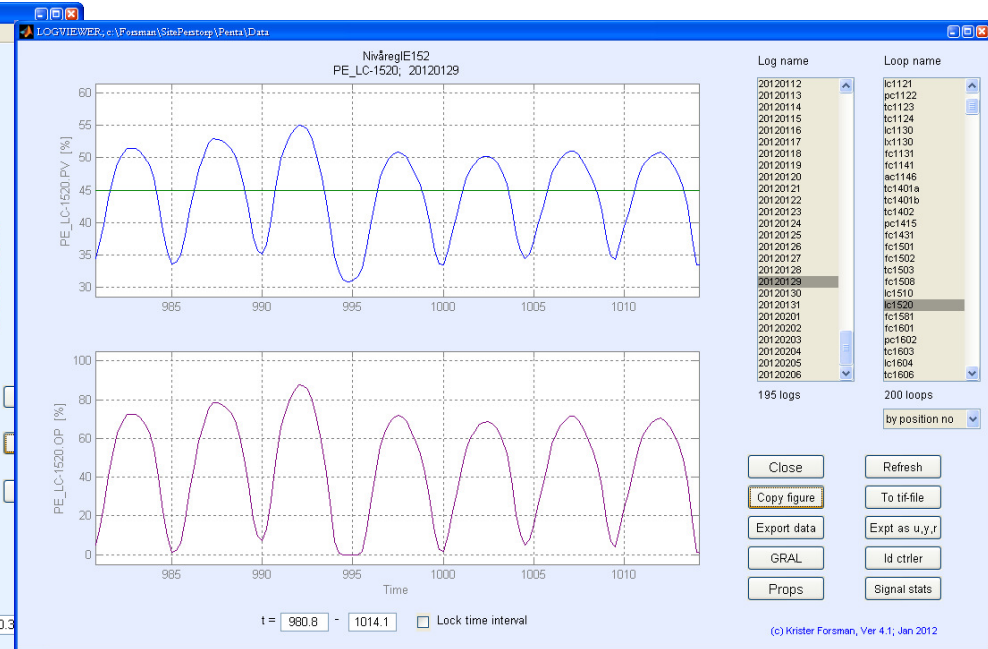
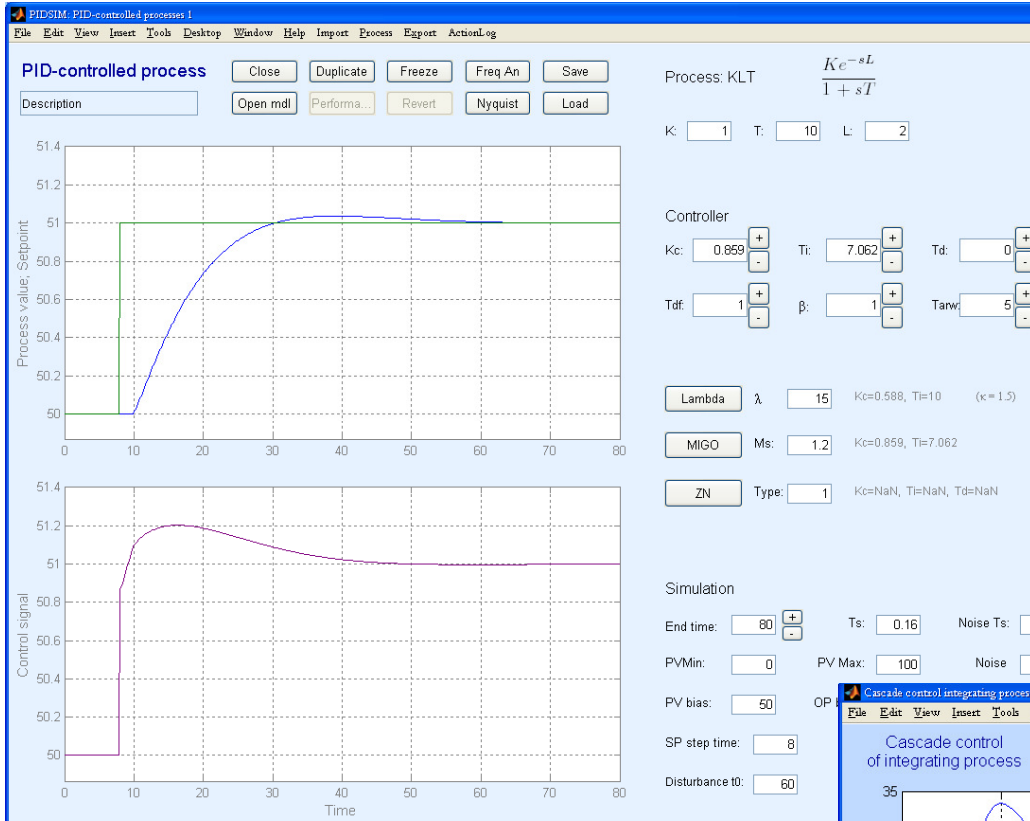

# Process model structures supported by our Matlab library

KLT	$\frac{Ke^{-sL}}{1+sT}$	}	~80% of all loops
Integrating	$\frac{k_v e^{-sL}}{s(1+sT)}$		
IPZ	$\frac{k_v(1+sT_2)e^{-sL}}{s(1+sT_1)}$	}	~15% of all loops
PPZ	$\frac{K(1+sT_2)e^{-sL}}{(1+sT_1)(1+sT_3)}$		
P3	$\frac{Ke^{-sL}}{(1+sT)^3}$		

# Representation of control structures: PID (piping and instrumentation diagram ☺)

Simple example: gas pipe

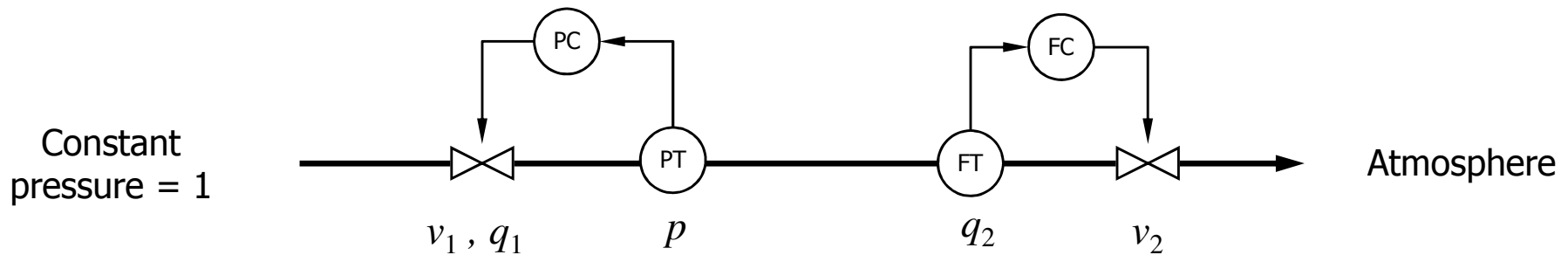

FC = flow controller, PC = pressure controller, LC = level ctrl, TC=temperature ctrl

FT = flow transmitter, etc

Why not use block diagrams, as in most control textbooks?

# Block diagram for the same process

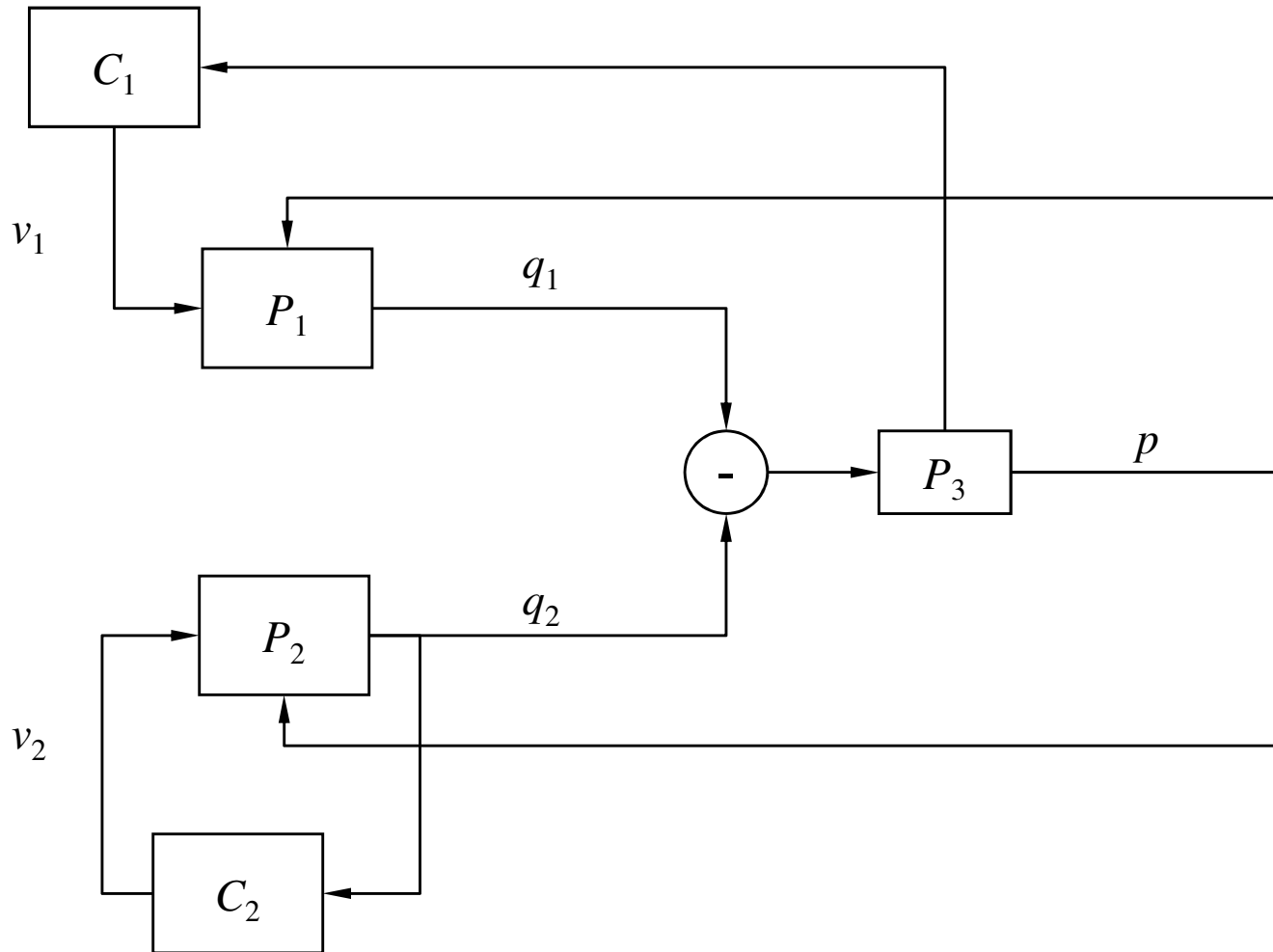

# Control optimization

A set of practical examples



# Ex: Level control with improvement opportunity

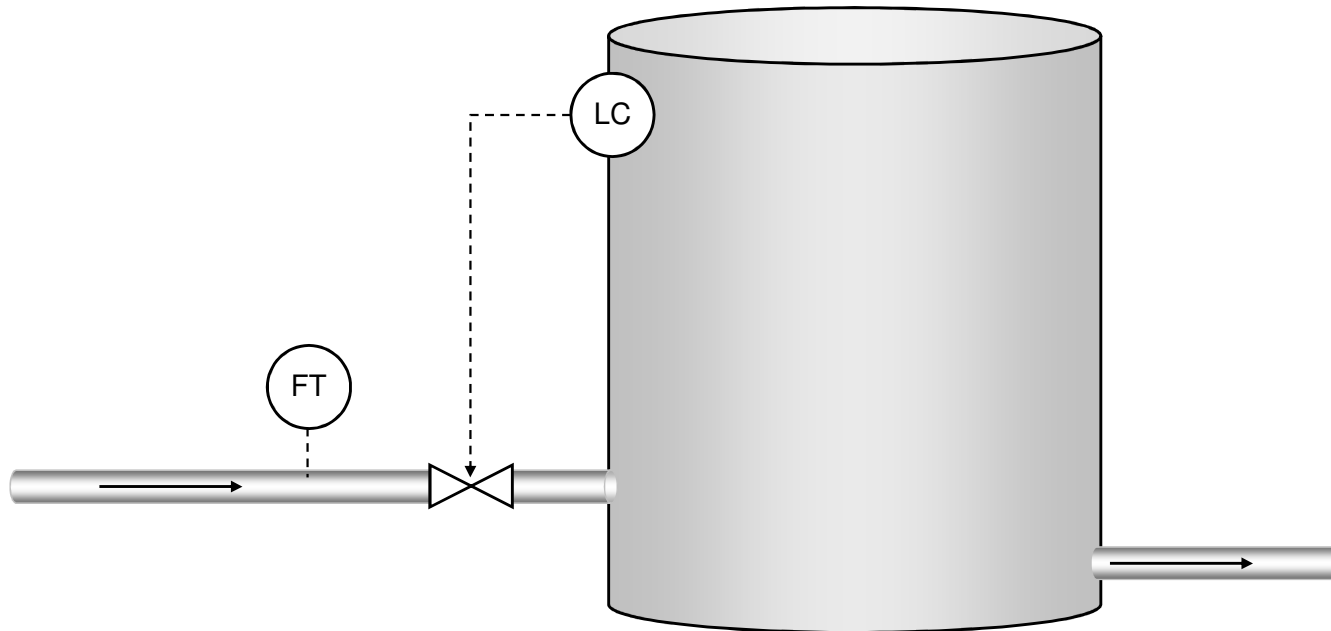

- The level in the tank varies too much, because there are pressure variations in the line for the incoming flow.
- We can't tune the controller more aggressively - then it becomes unstable.
- Can we still improve control performance?

# Solution: Control the flow too!

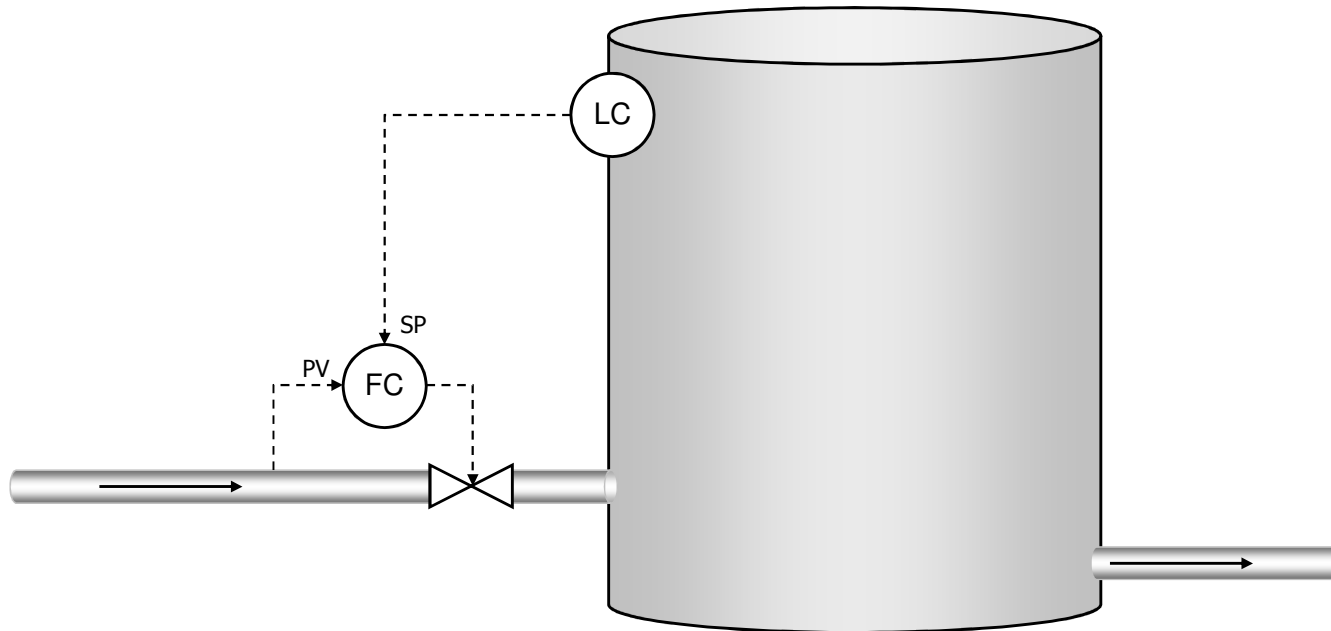

= Cascade control

# Cascade control block diagram

- Which disturbances motivate the use of cascade control?

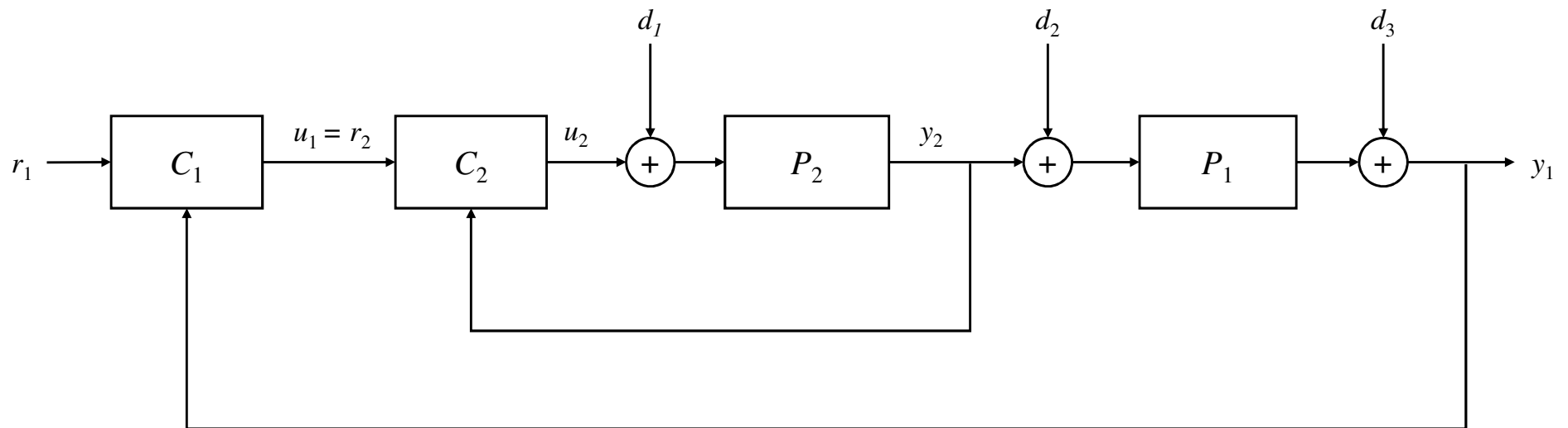

Answer:  $d_1$

# Example: Dilution process

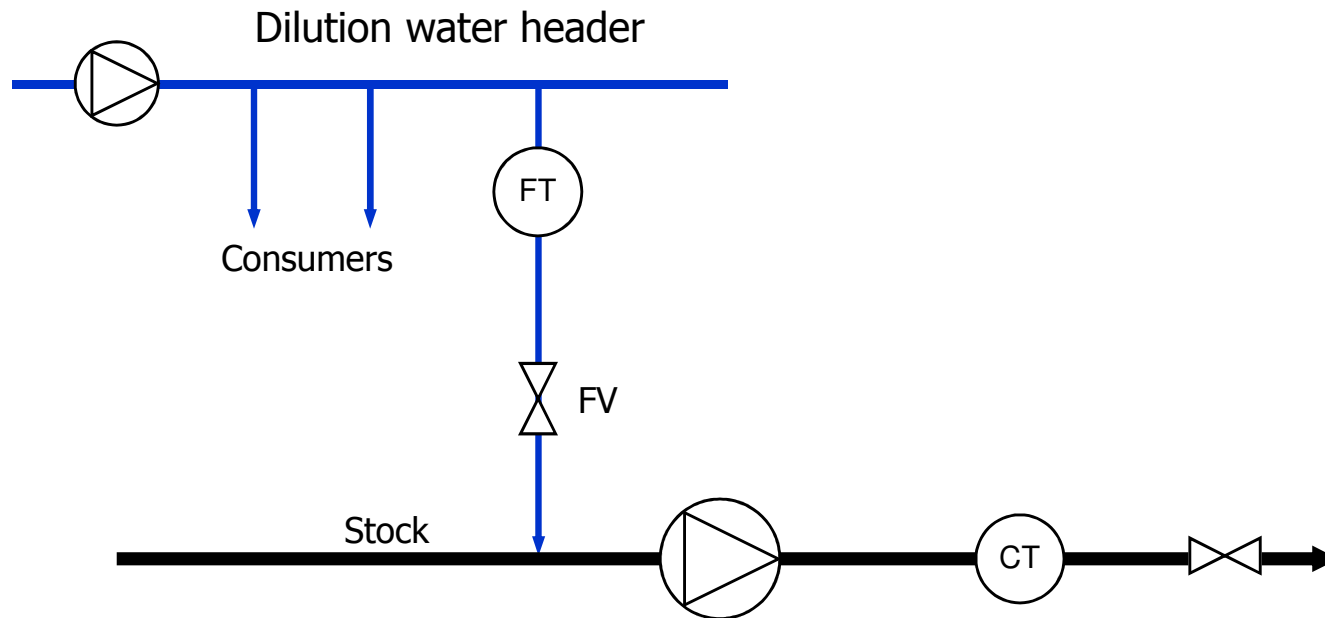

- Task: Control the concentration measured by the transmitter CT, by manipulating dilution water valve FV.
- How would you do that?

# Structure for concentration control

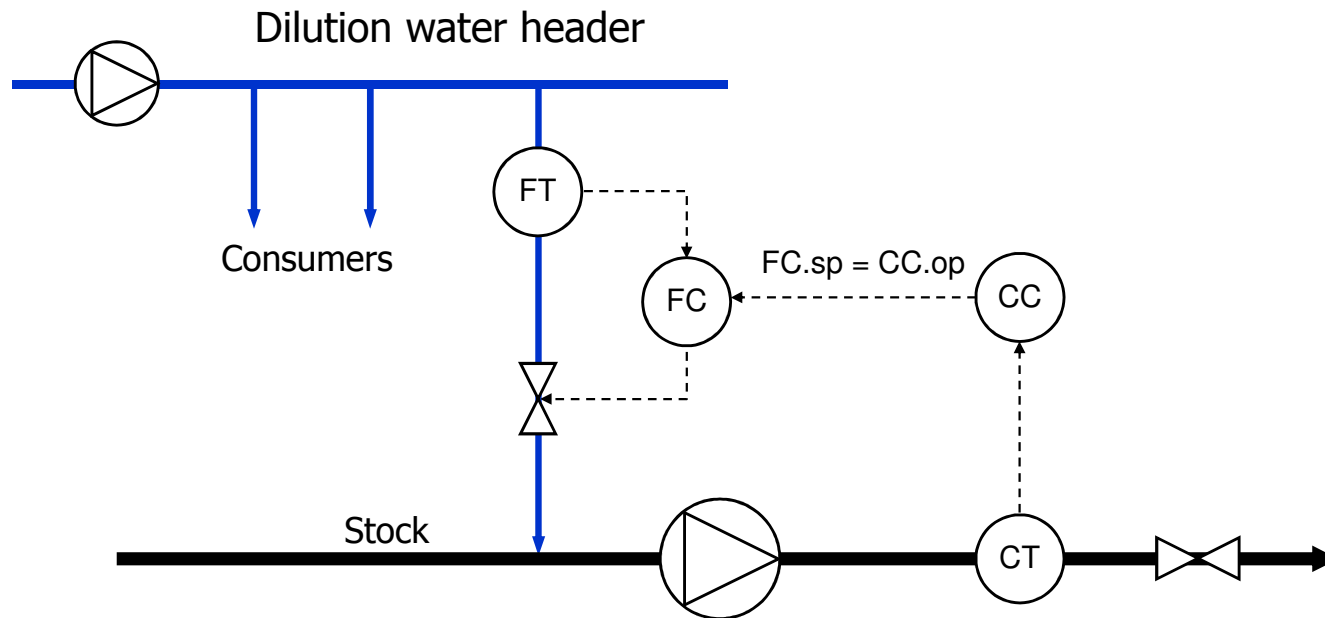

- Concentration (consistency) control in cascade against dilution water flow.
- Scenario: There is a pressure drop in the dilution water header, because one of the other consumers suddenly increases its demand.
- We will now see how the cascade controller reacts to this, depending on the tuning of master and slave controller.

Slave controller  
much faster  
than master.

Rule of thumb for  
cascade control  
to work:

**Time constant  
in slave 10  
times faster than  
in master.**

The disturbance  
is handled by  
the slave controller  
before the master  
controller reacts  
(in principle).

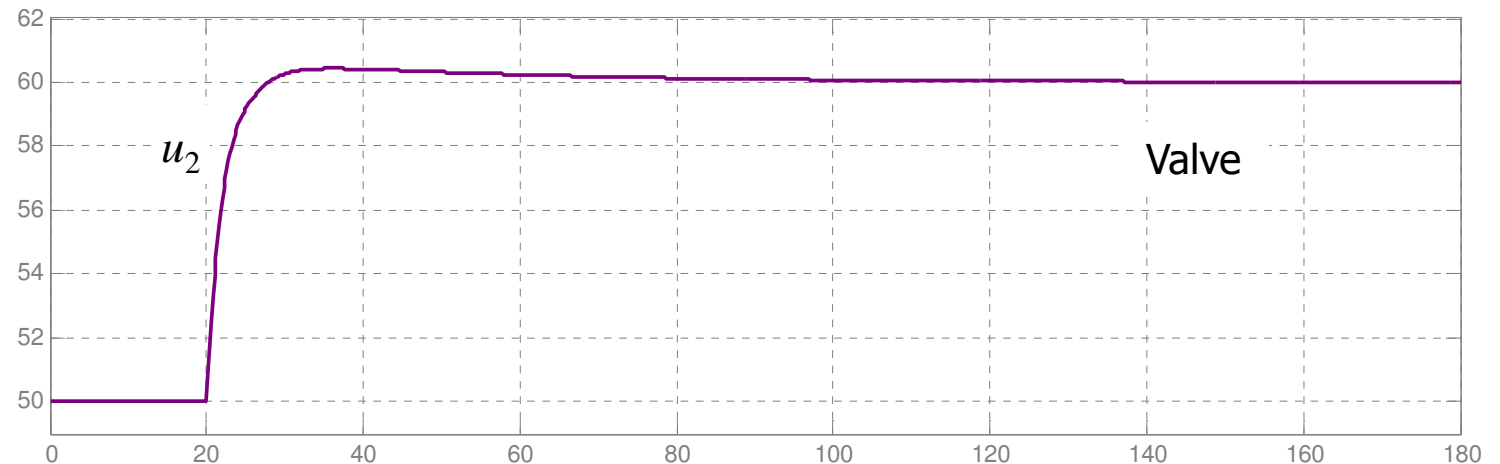
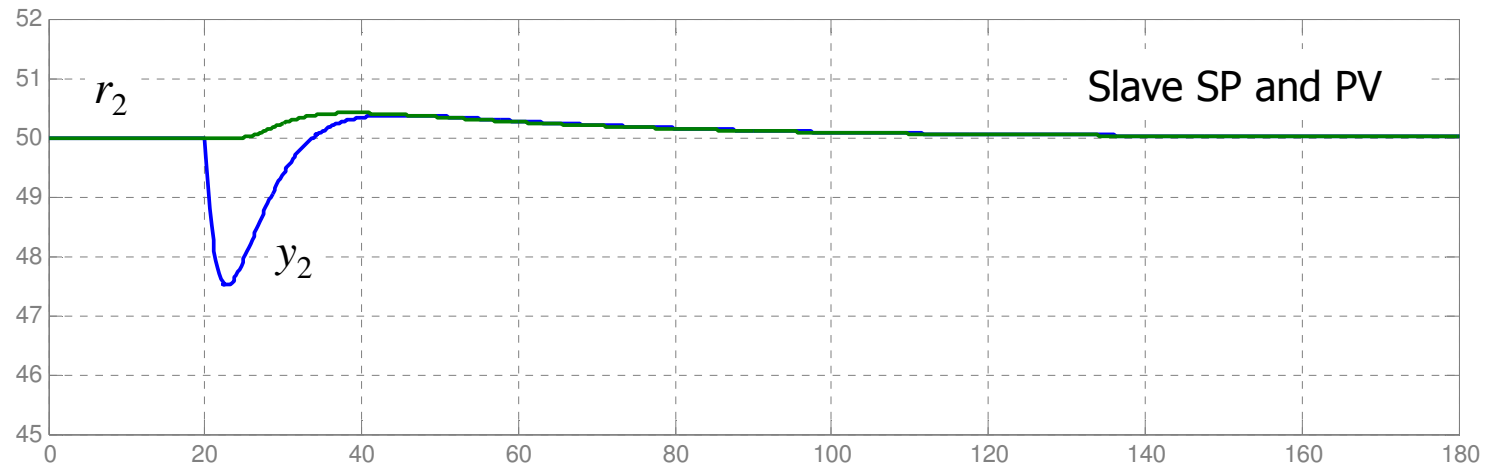
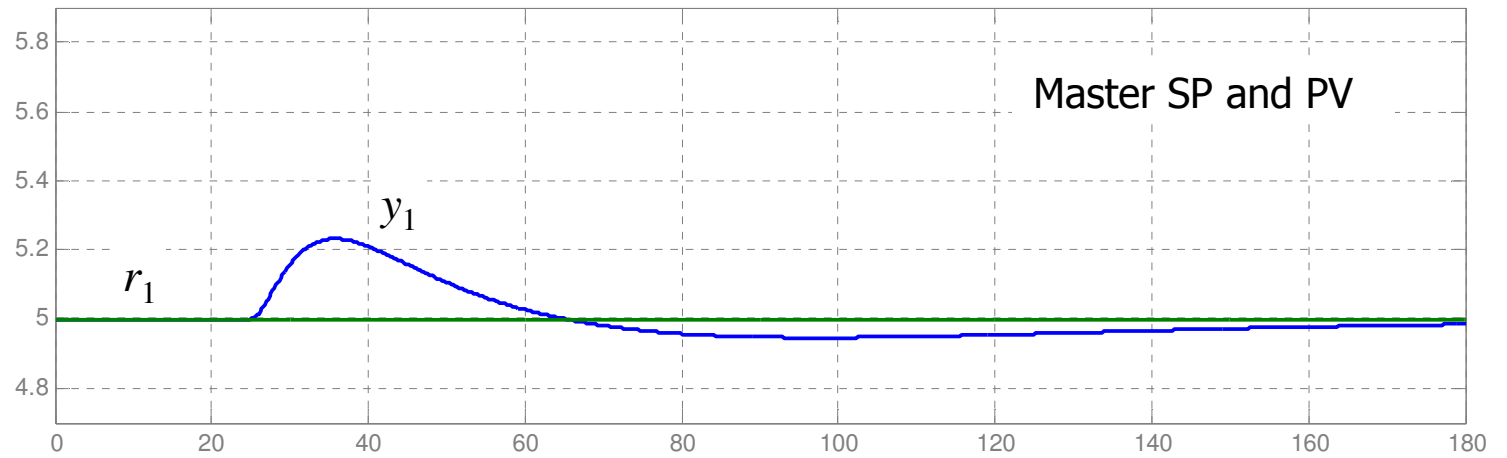

Difference between slave and master smaller than in previous slide.

The disturbance is handled by the slave controller but the master controller also reacts, later on.

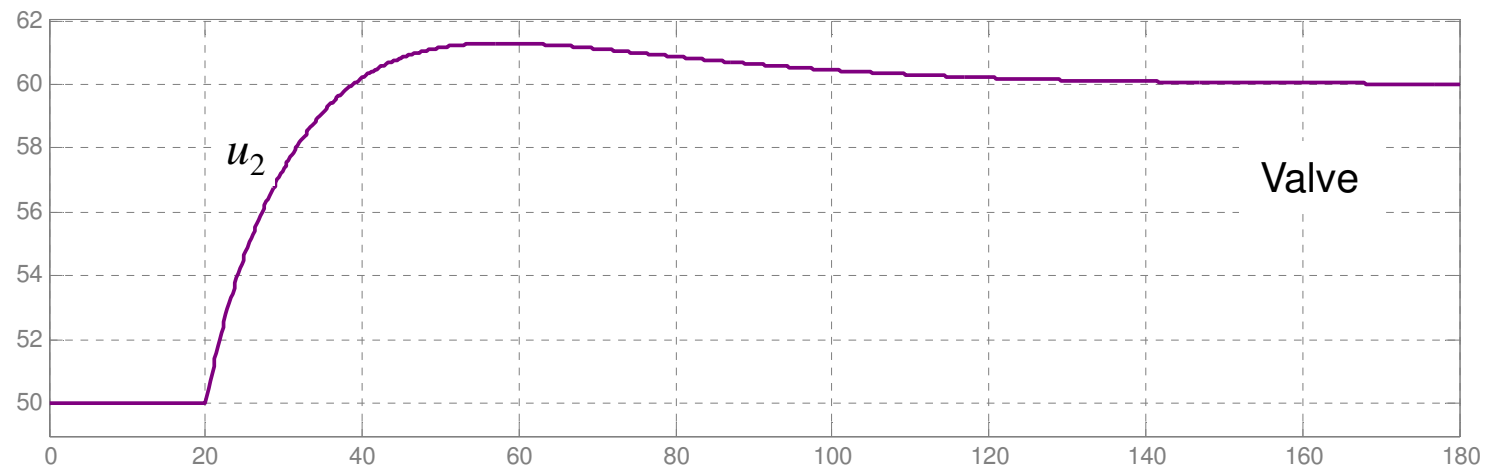
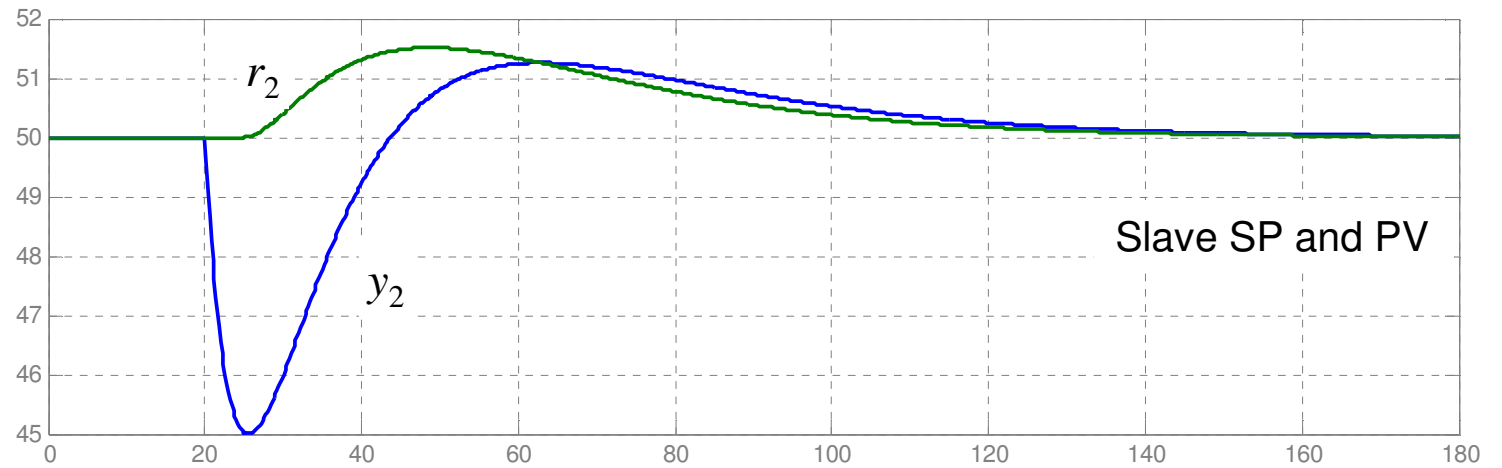
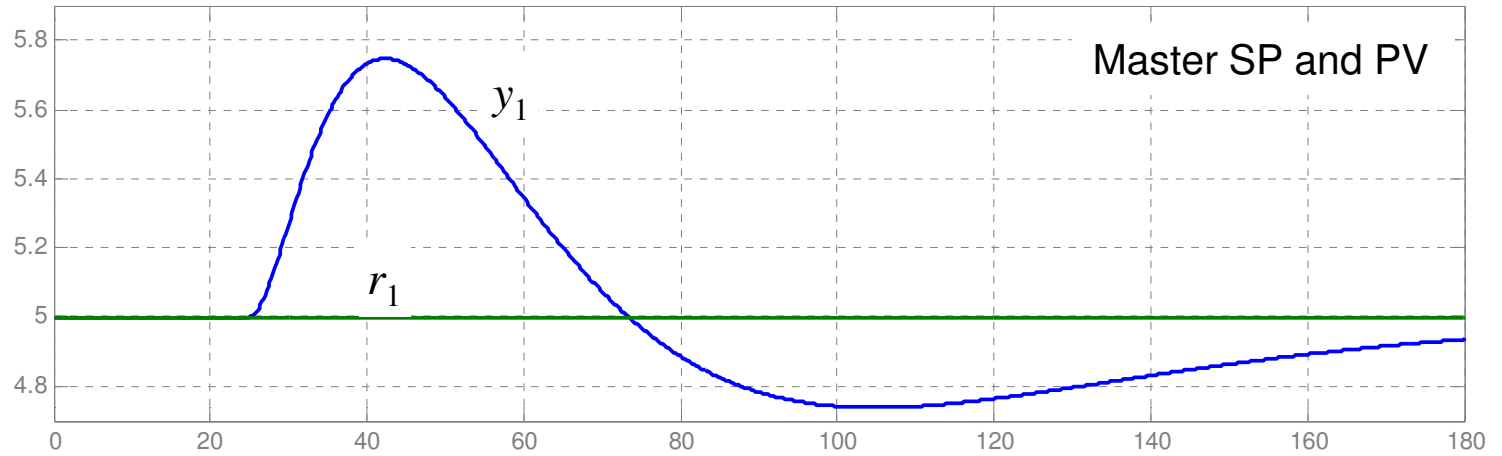

Master and slave controller almost equally fast.

The disturbance is thrown back and forth between master and slave.

Almost unstable.

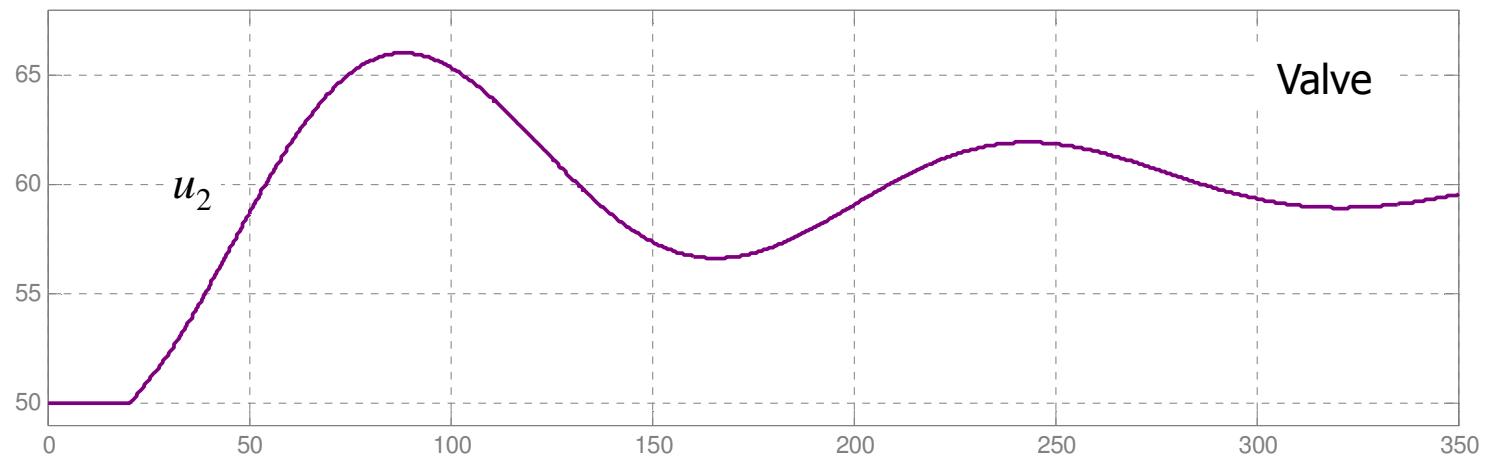
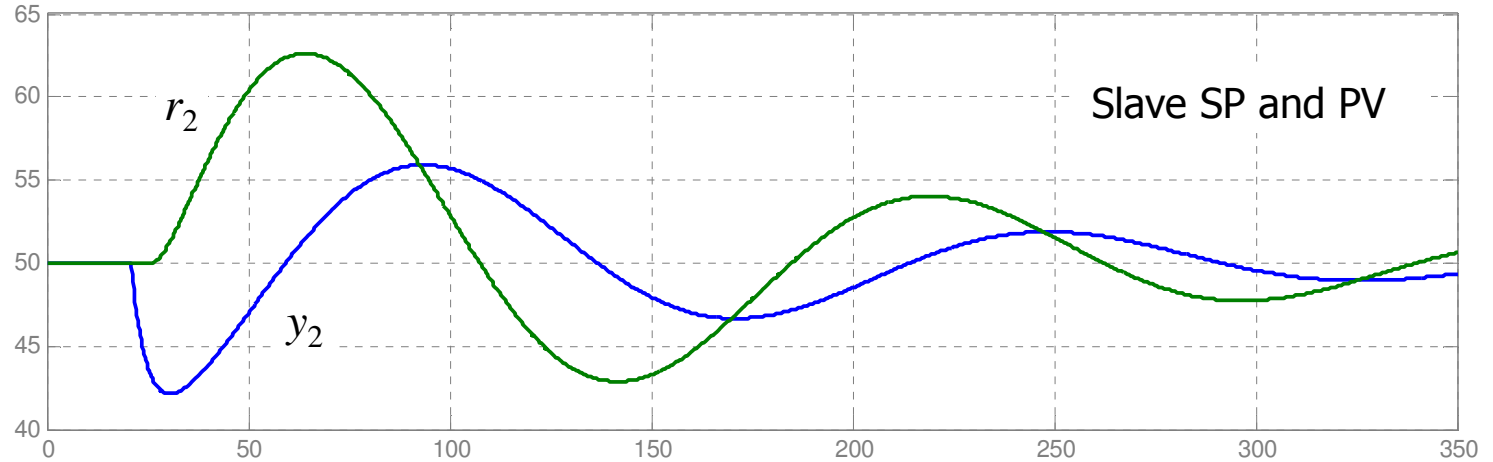
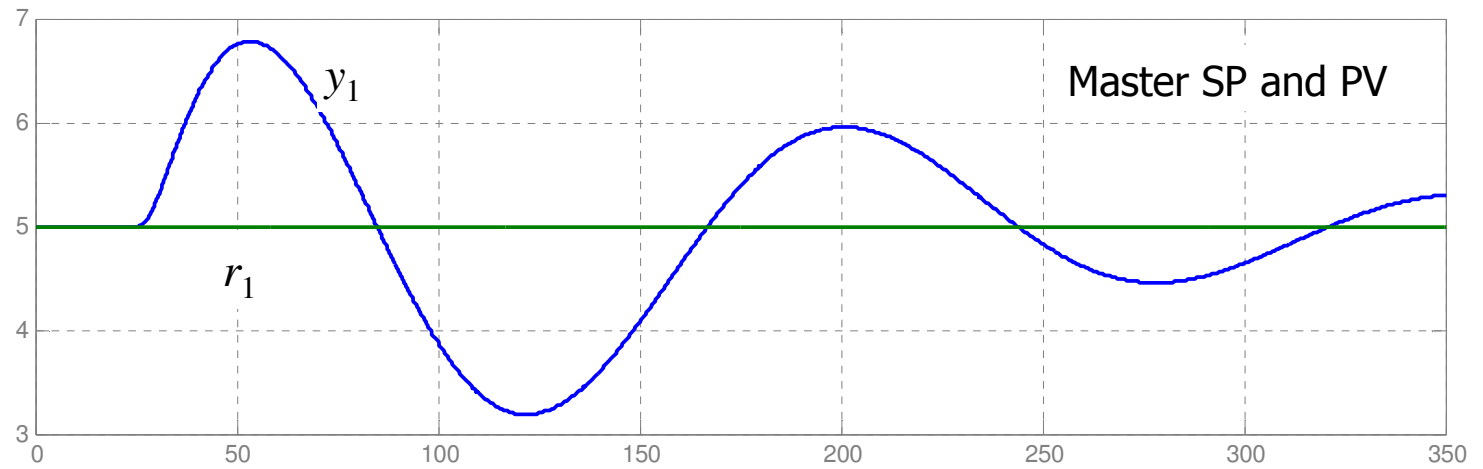



# New case

# Evaporator with poor level control

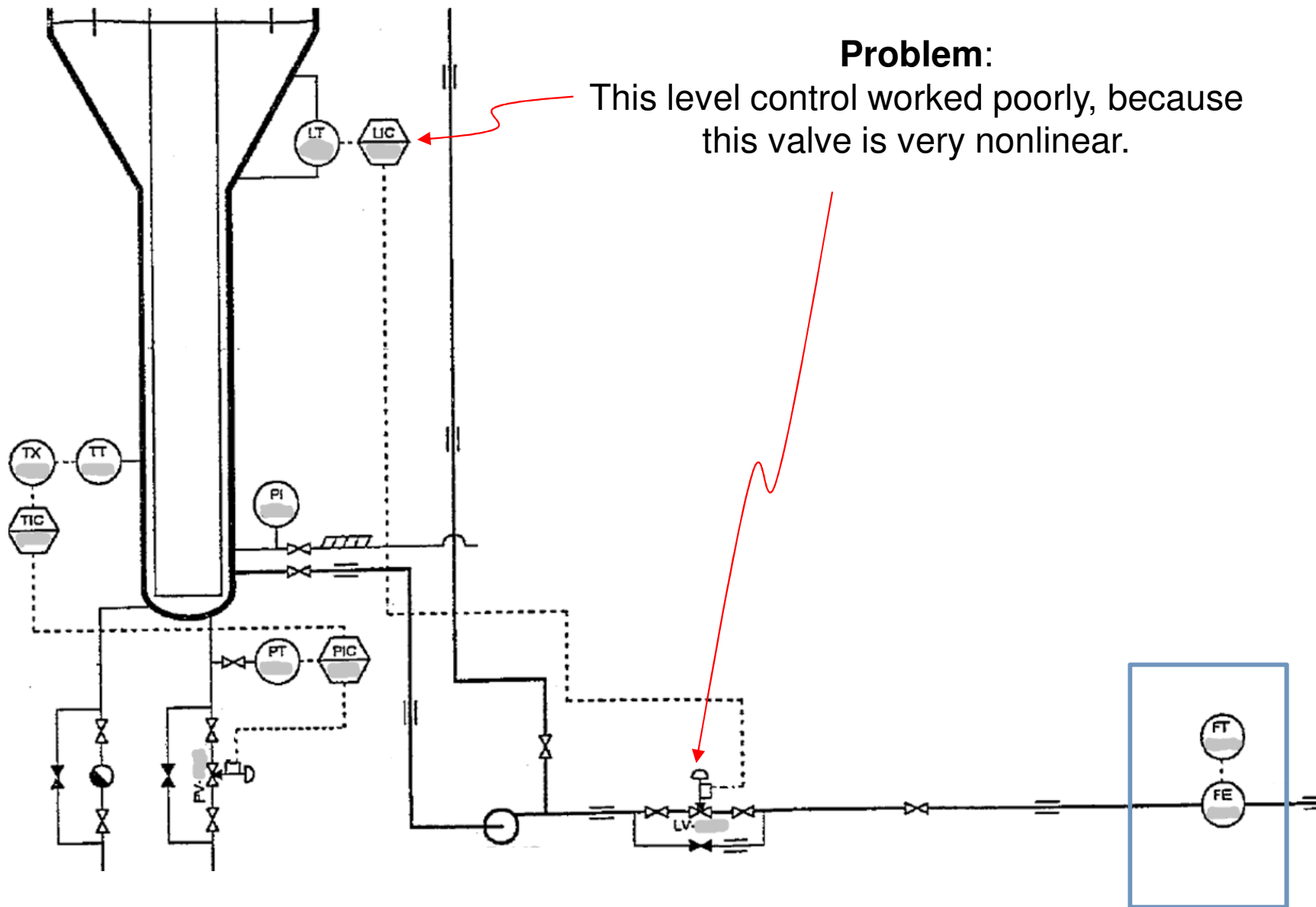

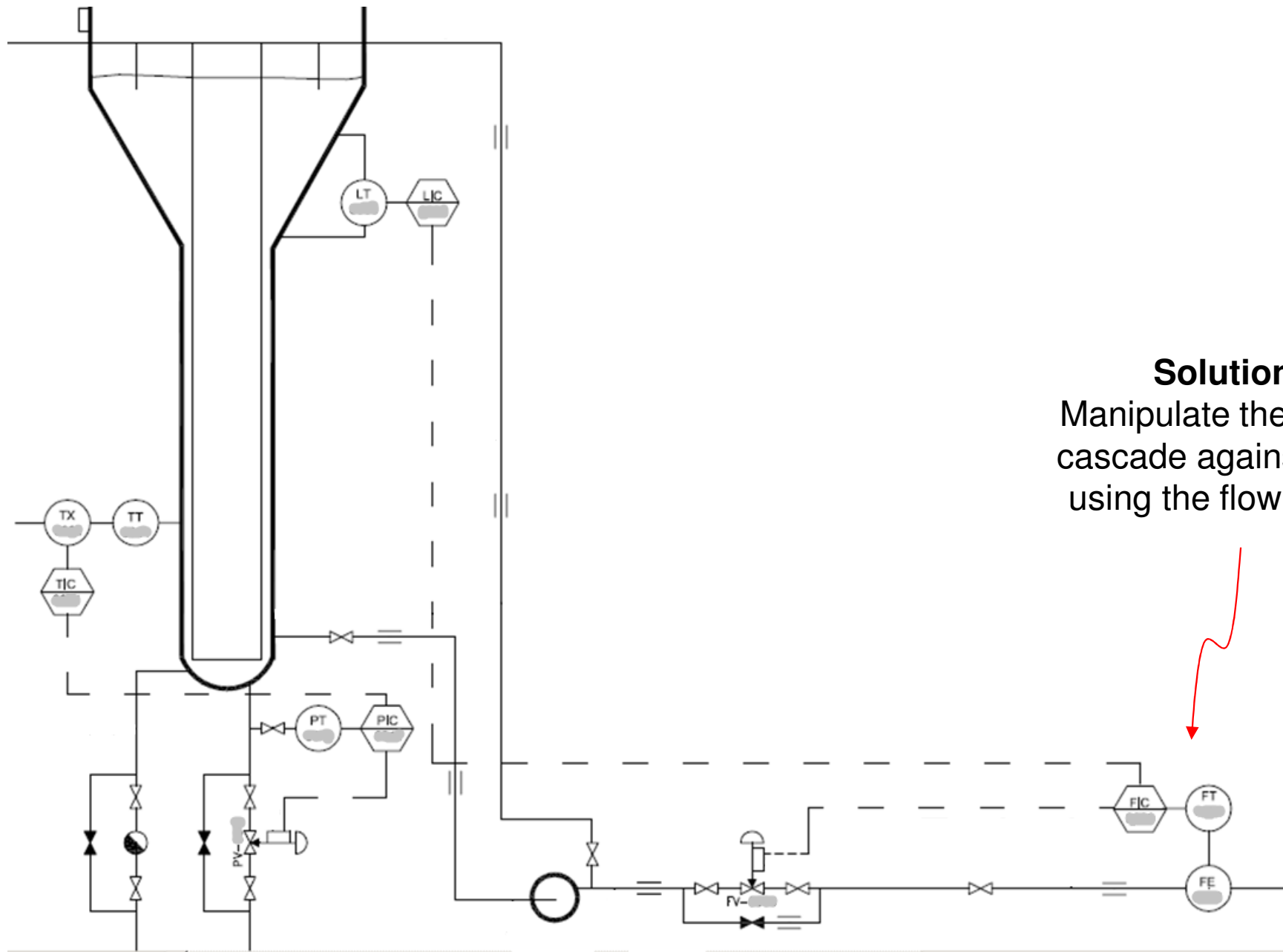

**Solution:**  
 Manipulate the flow in cascade against level, using the flow meter.



# More stable level and smoother flow using cascade control

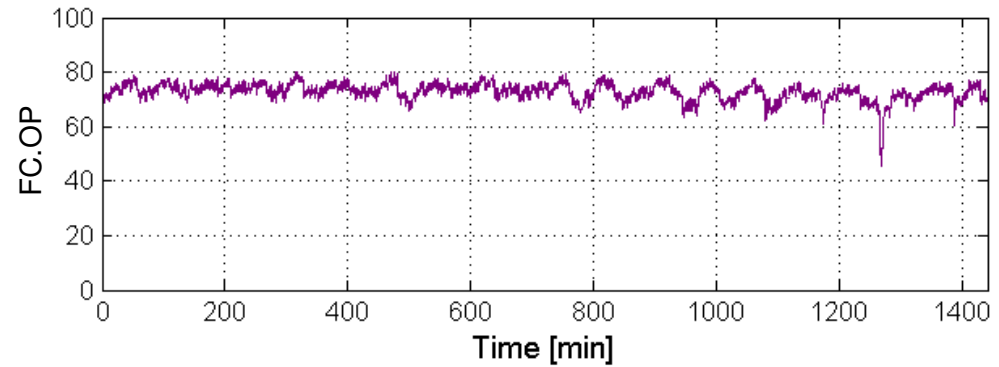
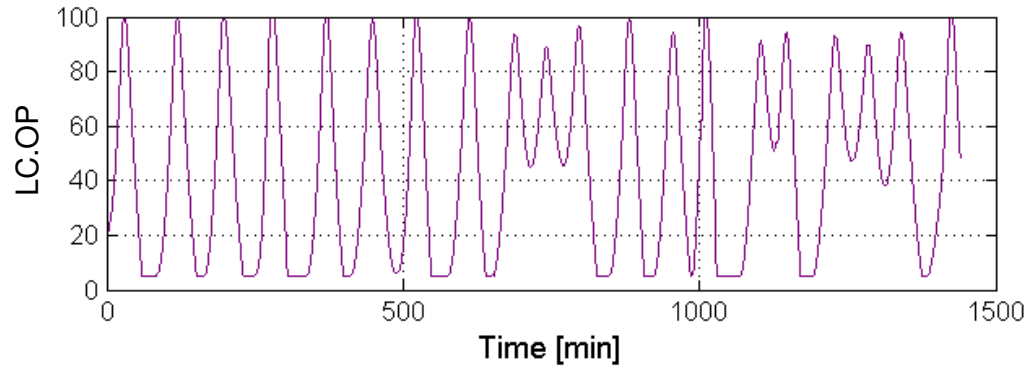
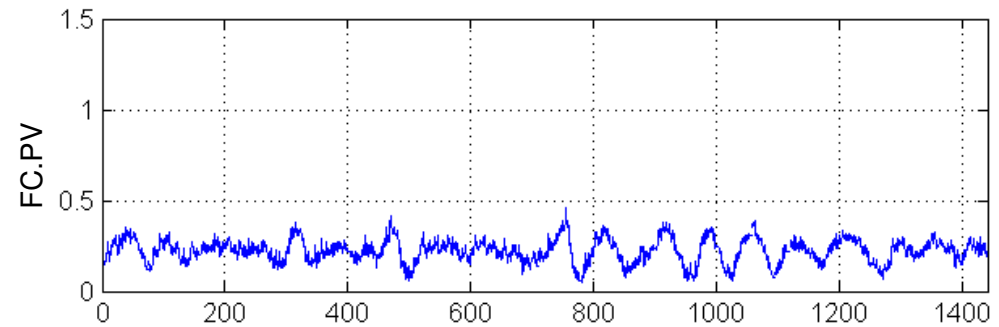
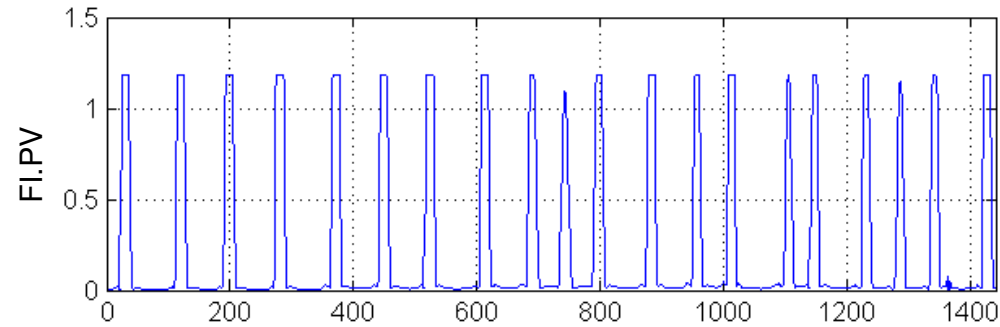
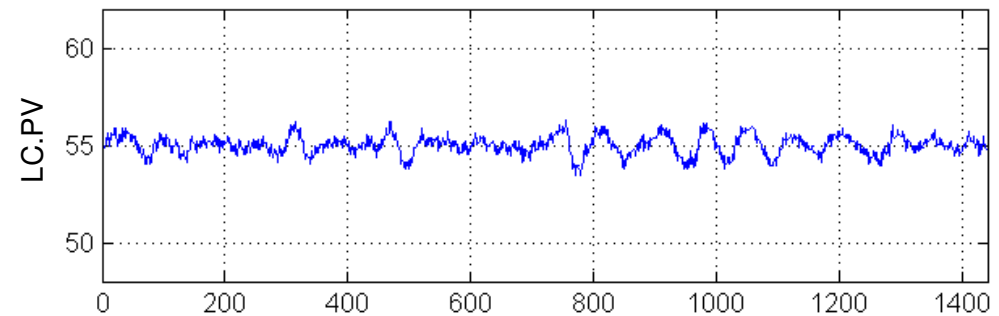
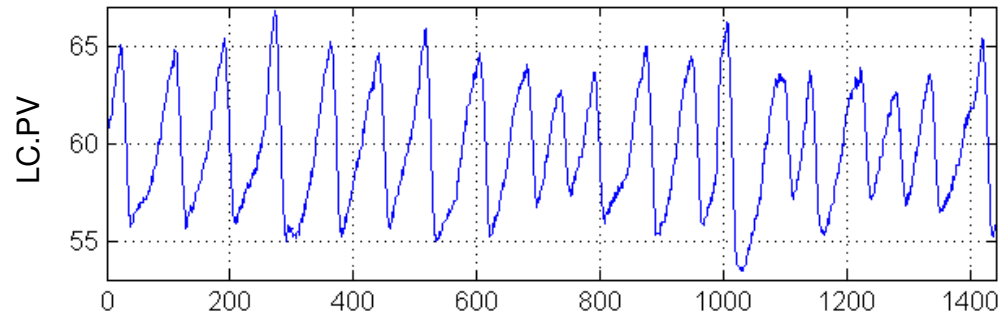

In this case, cascade control is used to **linearize the slave process**, rather than for disturbance rejection.

# Ex: Level control with improvement opportunity

- The level in the tank varies too much because of variations in output flow.
- We can't tune the controller more aggressively - then it becomes unstable.
- Can we still improve control performance?

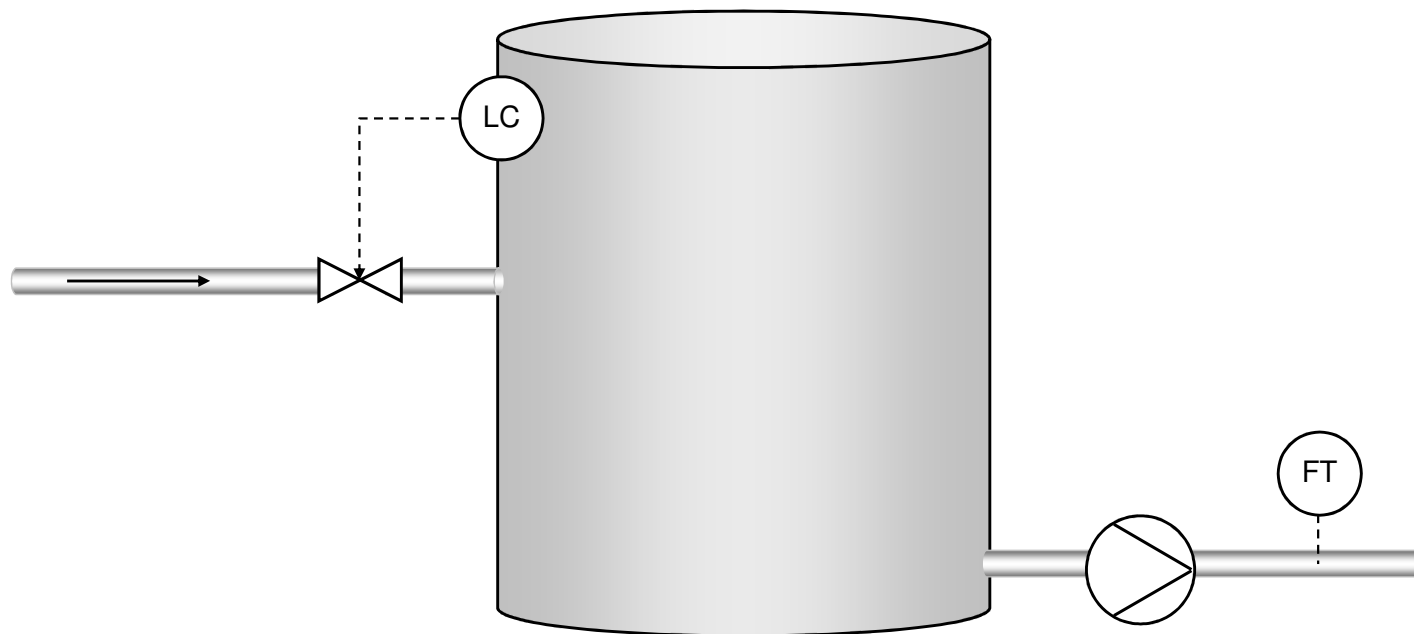

# Feedforward: Give early information to the controller

$$u(t) = \underbrace{K_c \left( e(t) + \frac{1}{T_i} \int_0^t e \right)}_{\text{Feedback term}} + \underbrace{u_{FF}}_{\text{Feedforward term}}$$

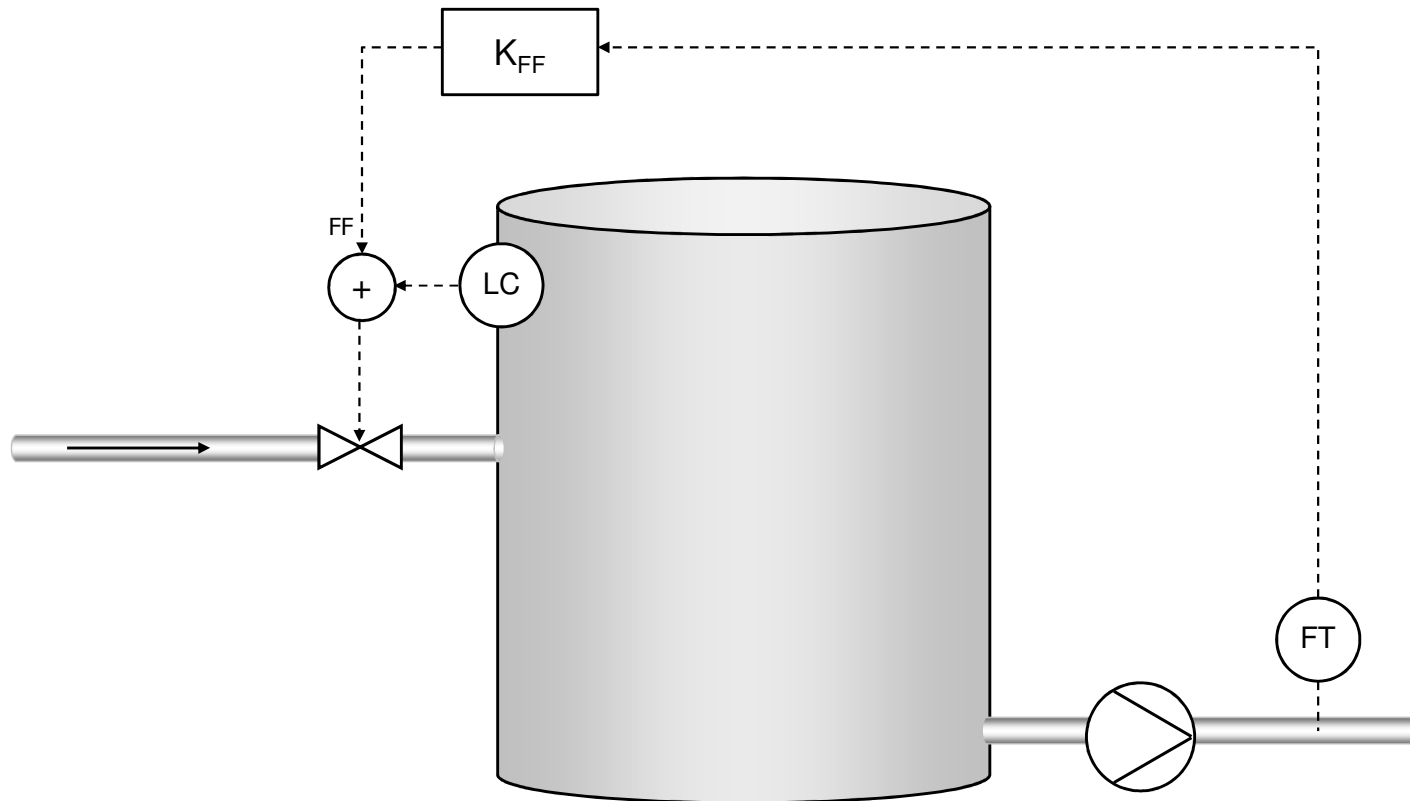

# Density control in a dissolver

Issue: Sometimes one of the flows FC-19 or FC-21 is closed for cleaning the centrifuge.

Then there will be a large deviation in density in the dissolver.

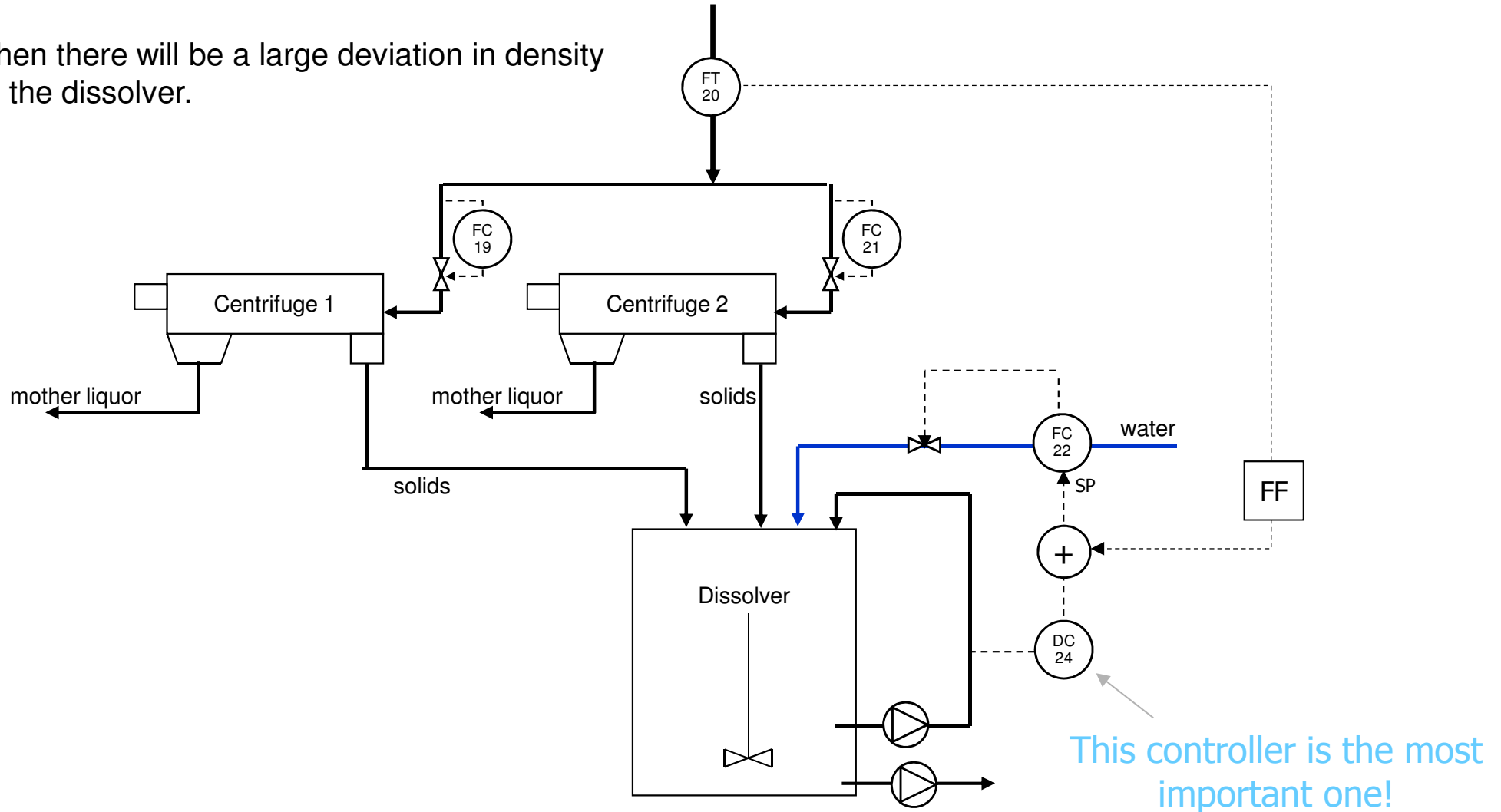

# Dissolver: FF and PI tuning reduces variations

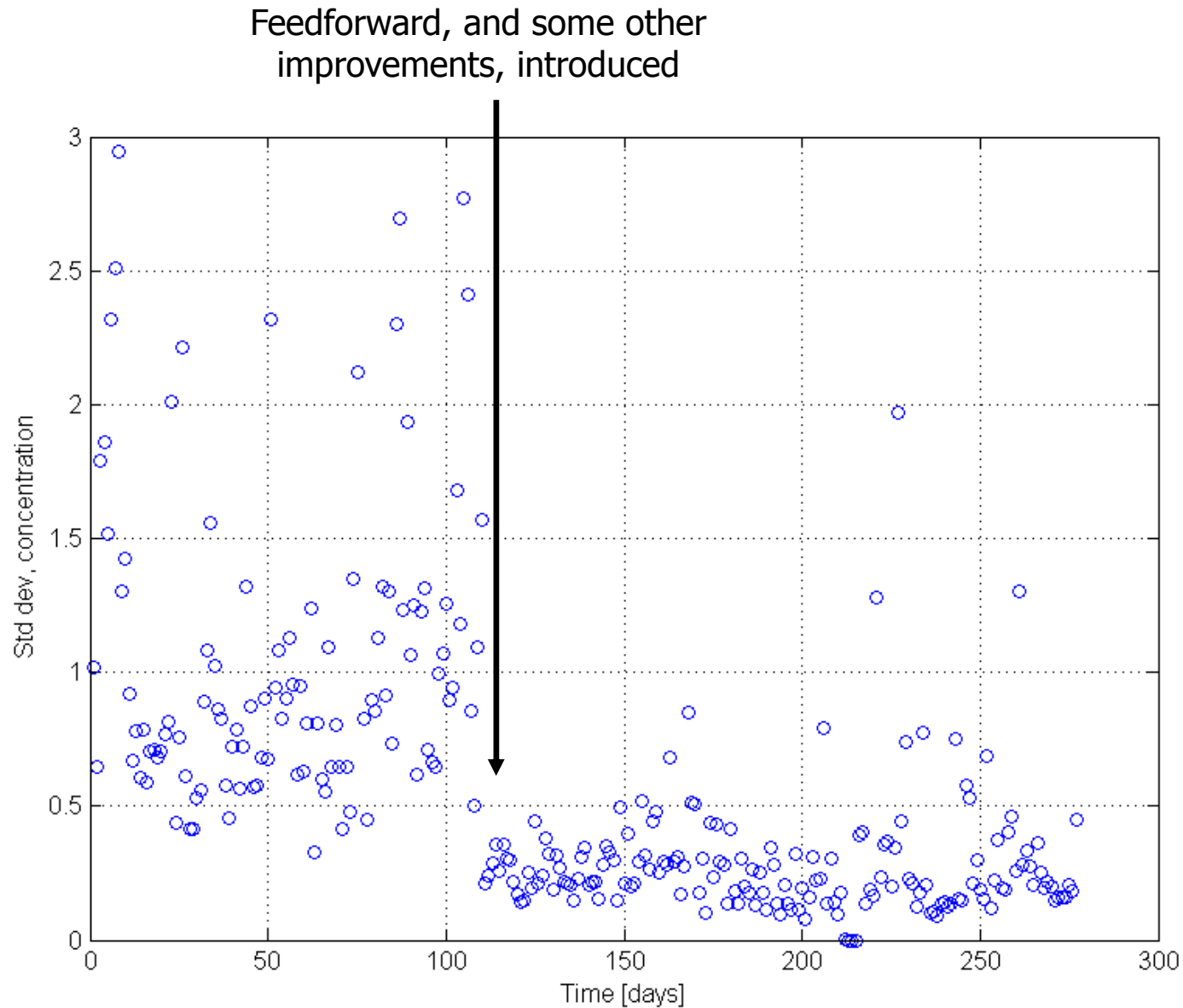



# New case

# Evaporators: Ratio control issue

Process: Raise the concentration by boiling water away.

Raw material feed is master

Steam flow in ratio against feed

# Traditional ratio control structure

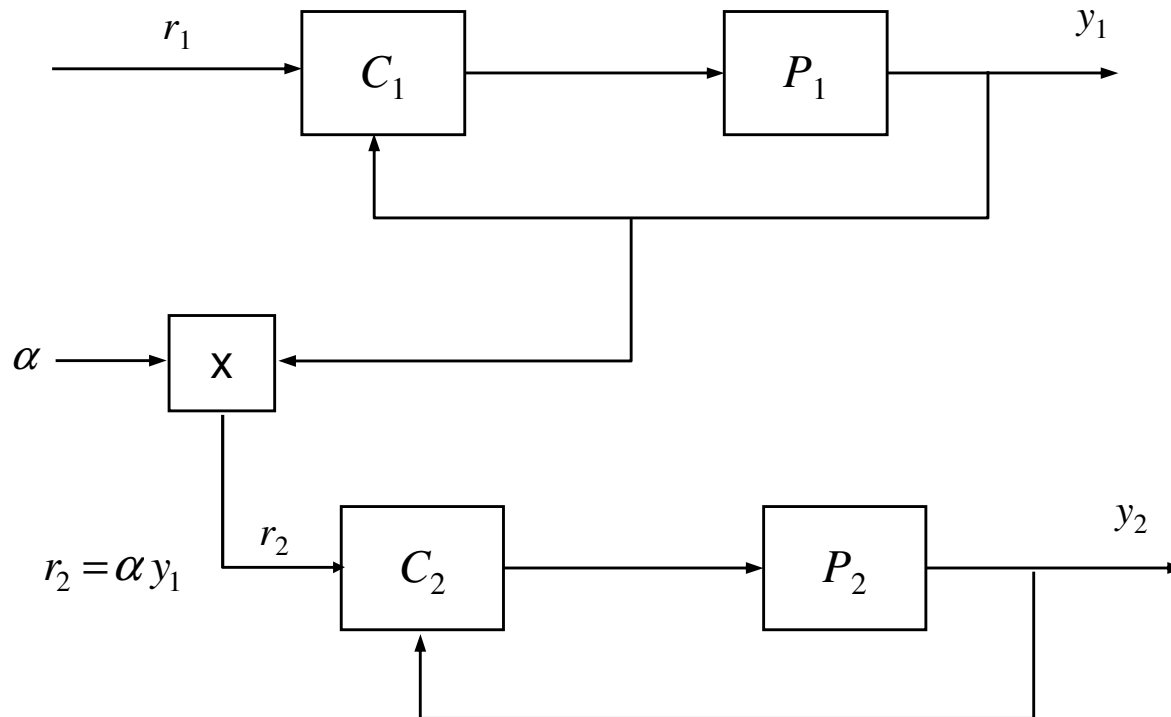

# Disadvantage with this structure

Feed; Setpoint

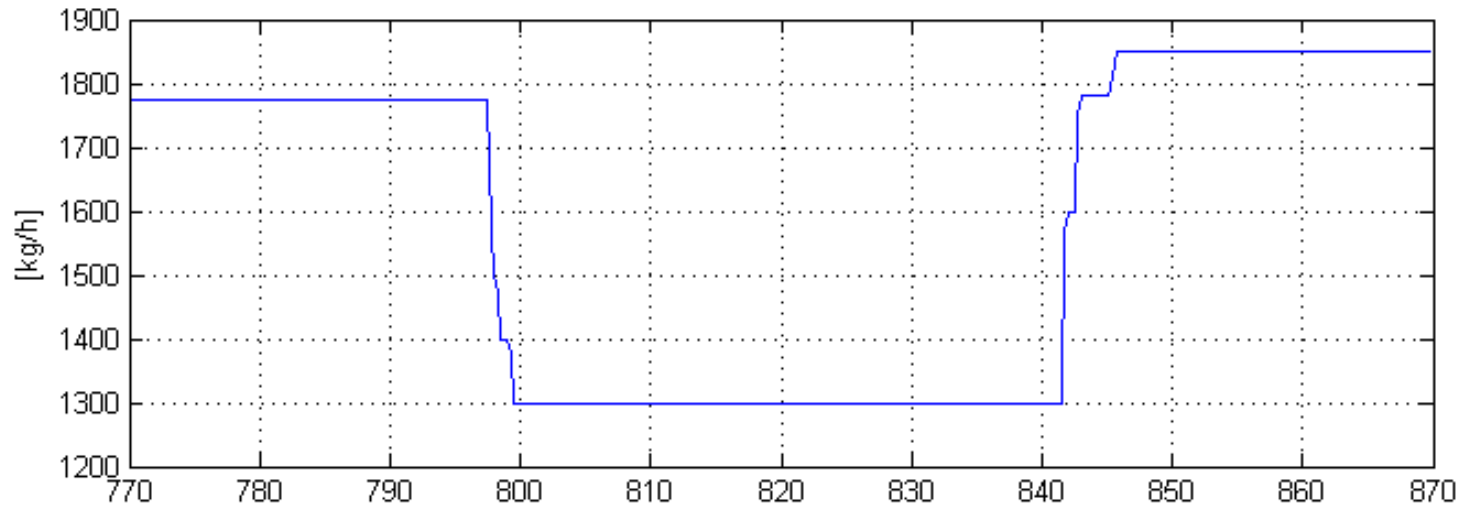

Concentration

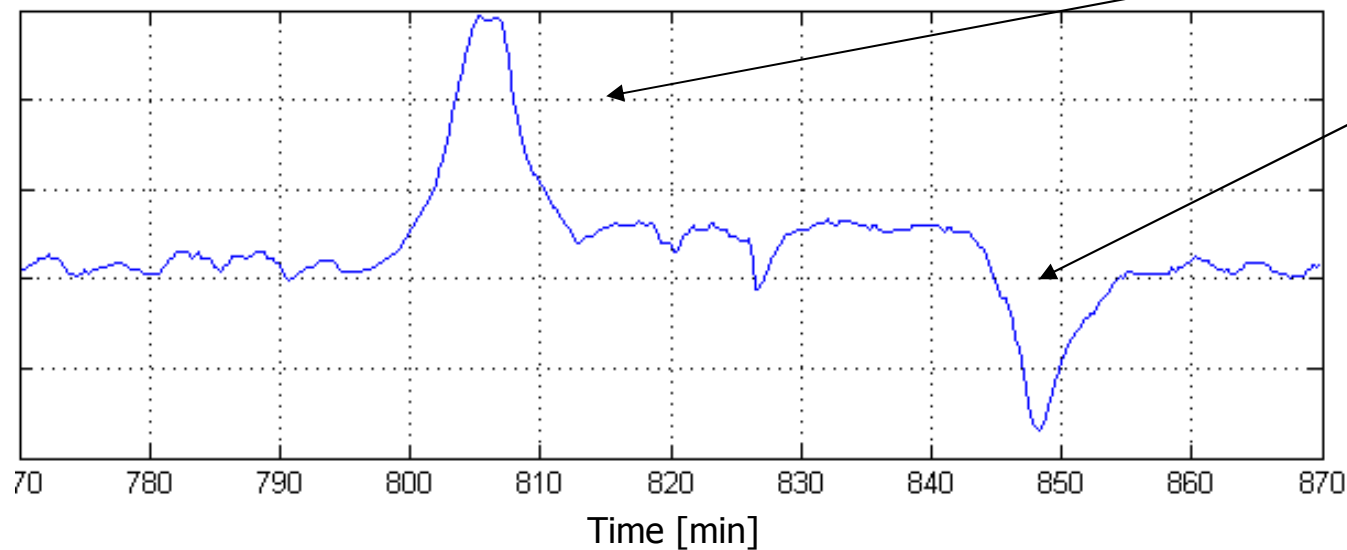

Why do we get humps in concentration?

# Same scenario: comparison feed flow – steam

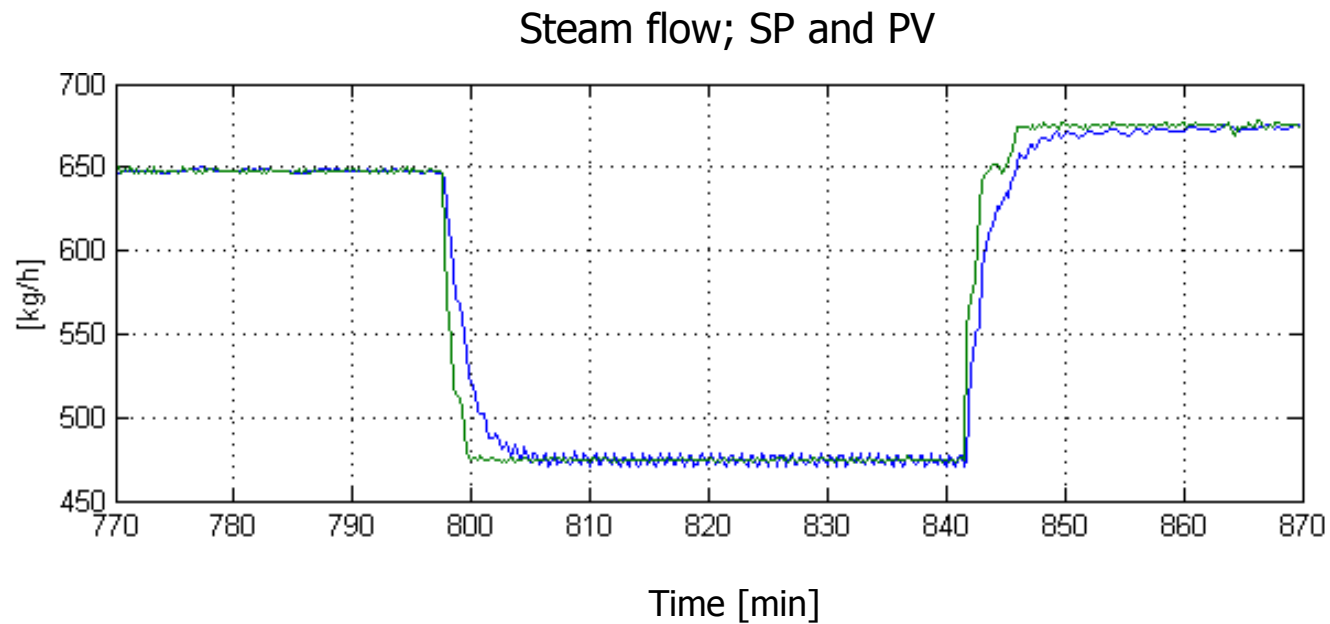
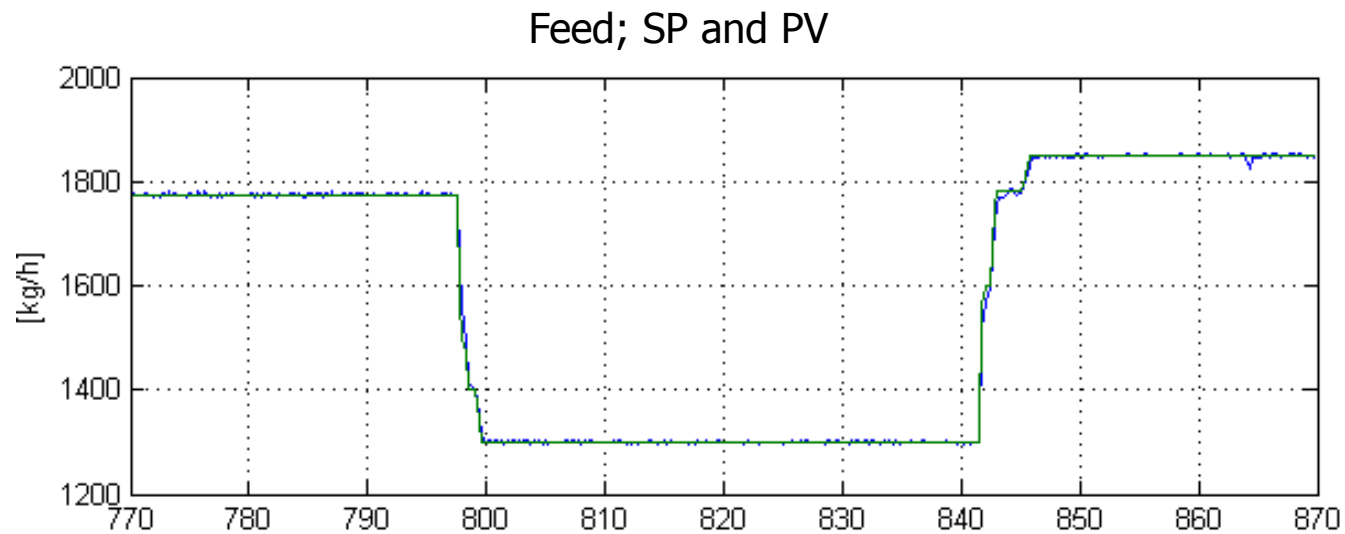

# The ratio steam / feed not constant during SP-changes

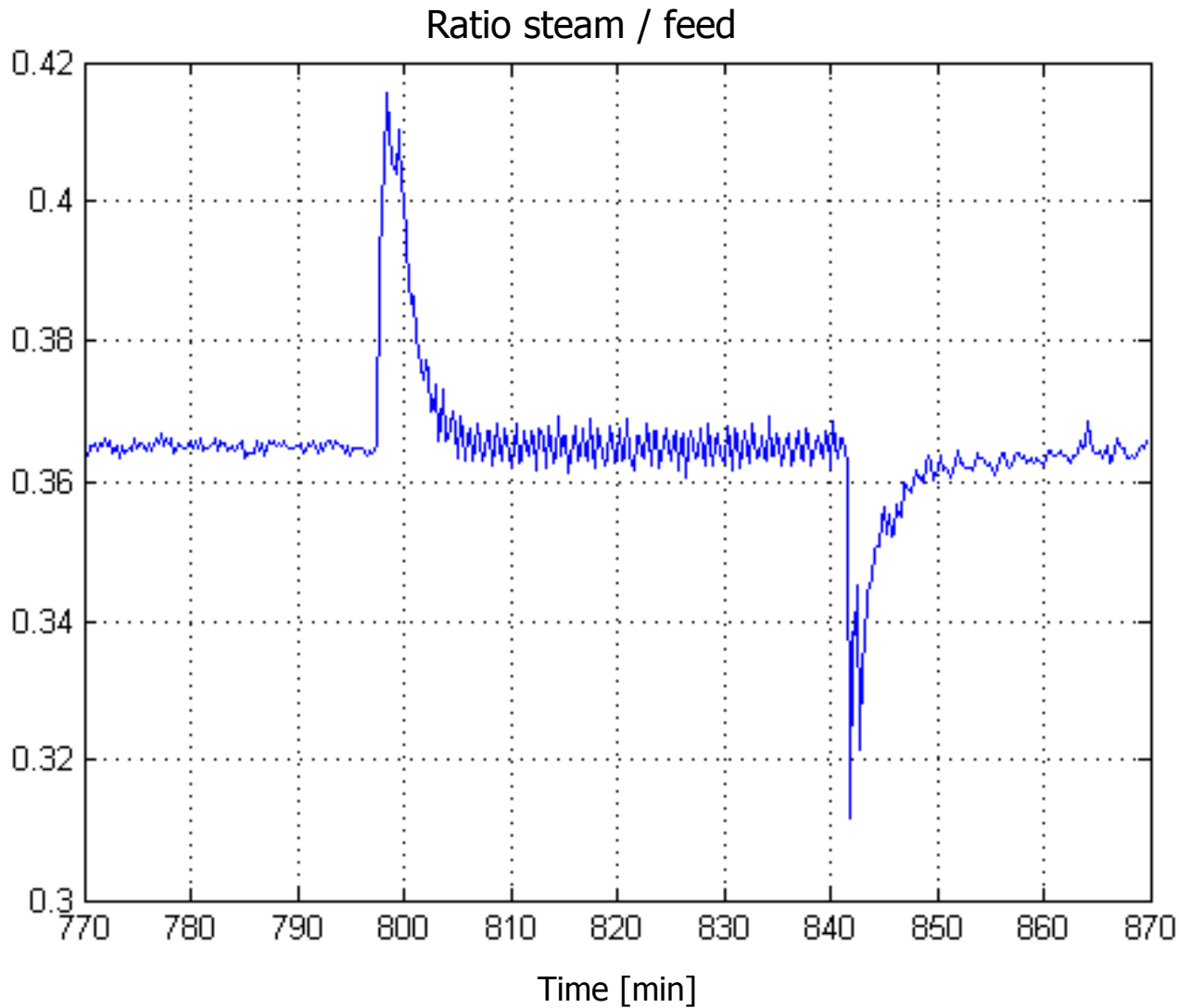

What should we do  
in order to reduce  
the deviation in ratio?

# Speed up steam flow controller! Result:

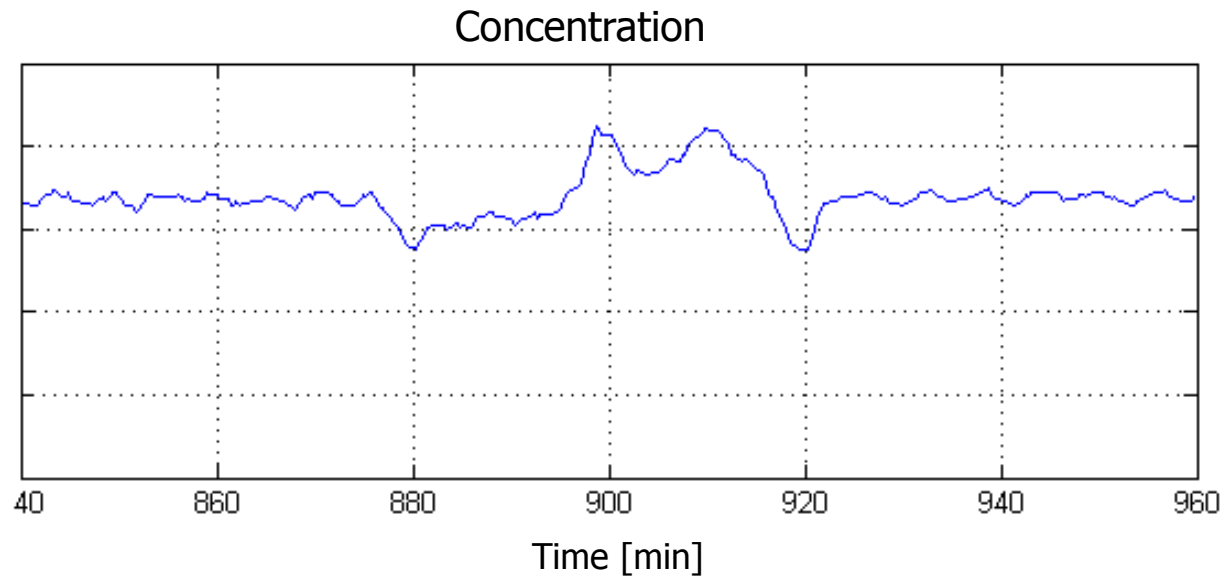
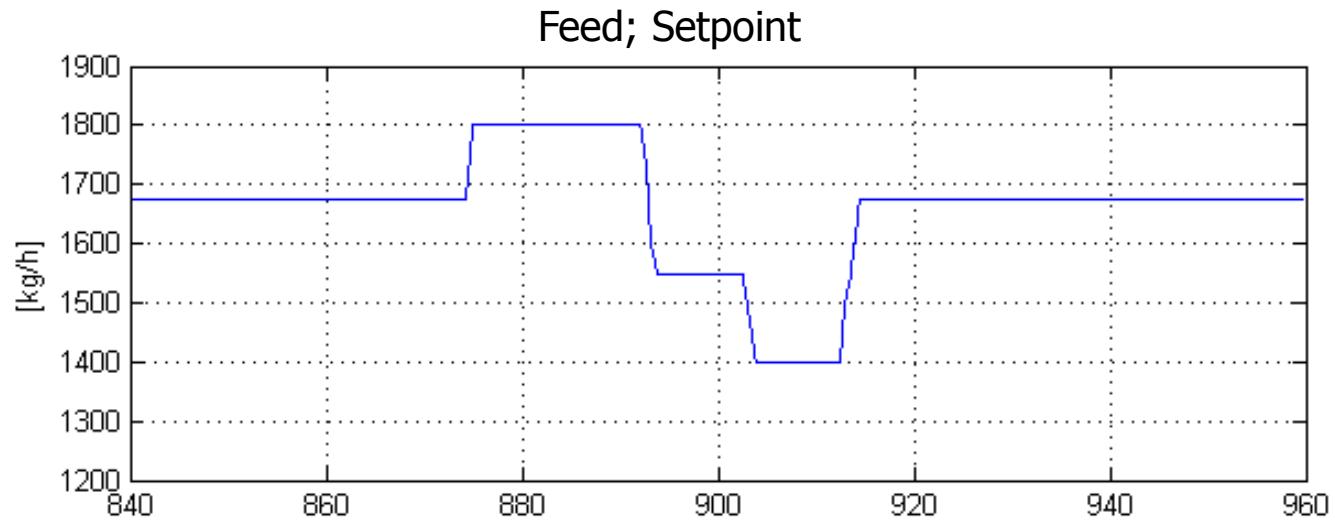

Feed; SP and PV

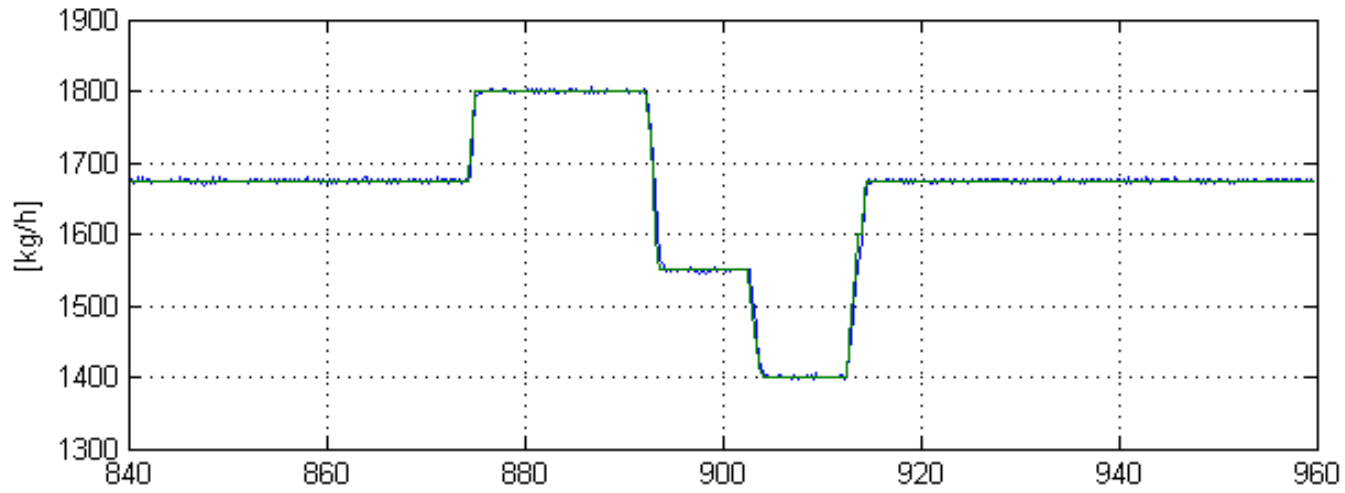

Steam flow; SP and PV

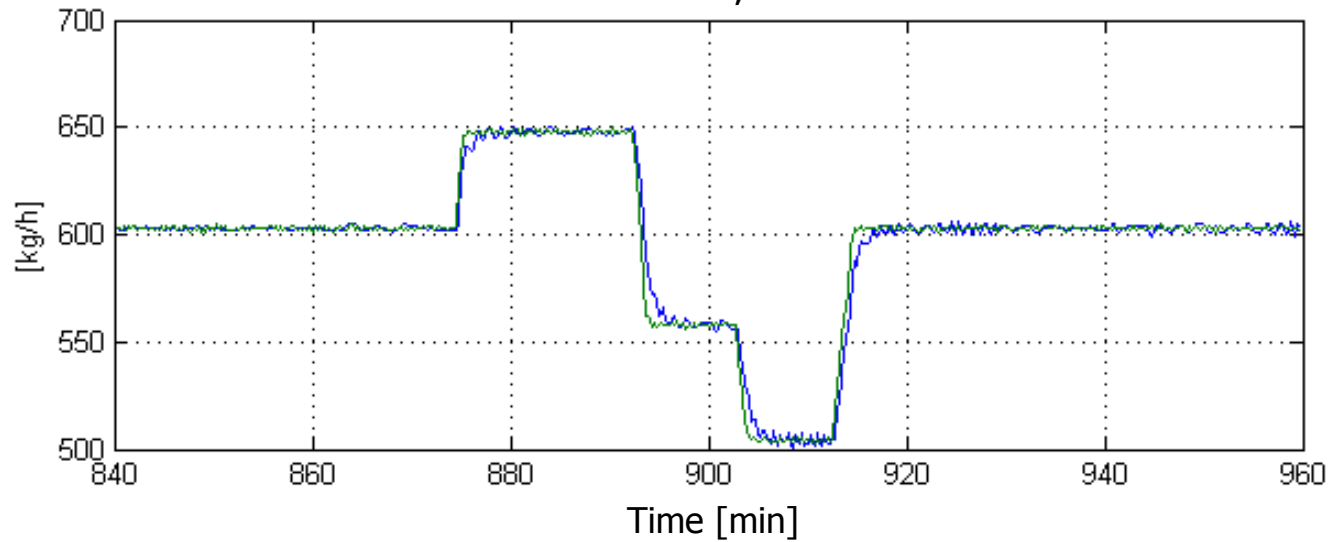



# Current control structure

Is there a different structure that would reduce deviations even more?

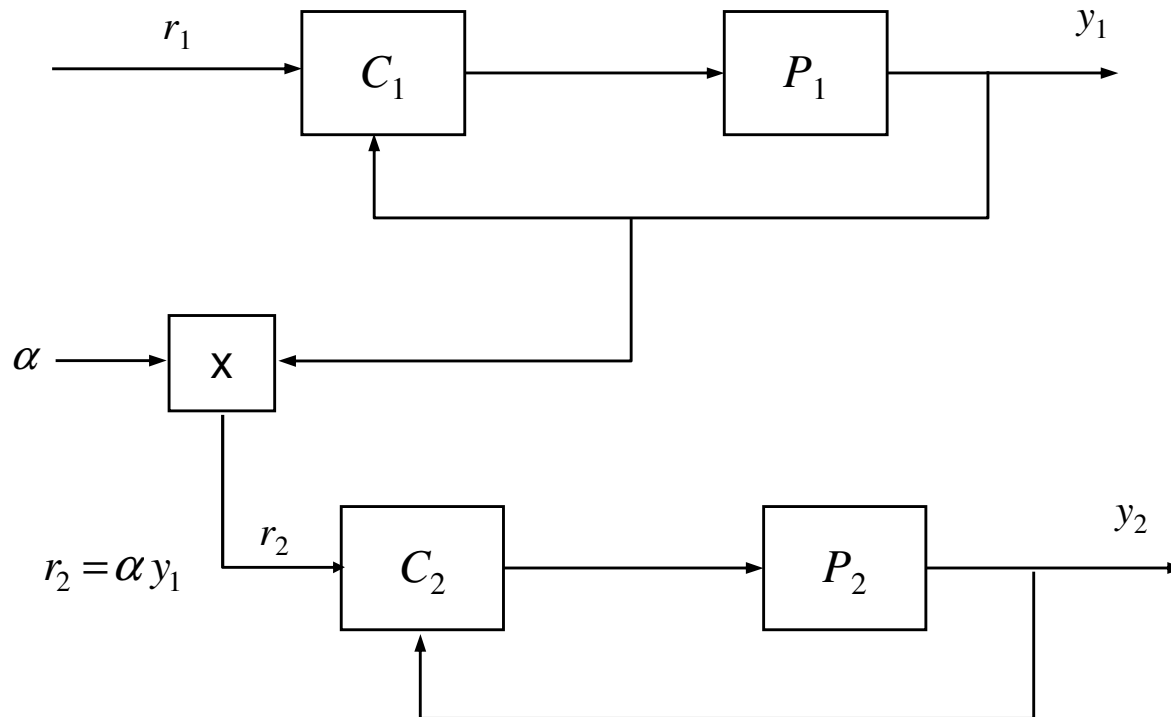

# Alternative structure

The SP of the slave is calculated from master **SP** rather than master **PV**!

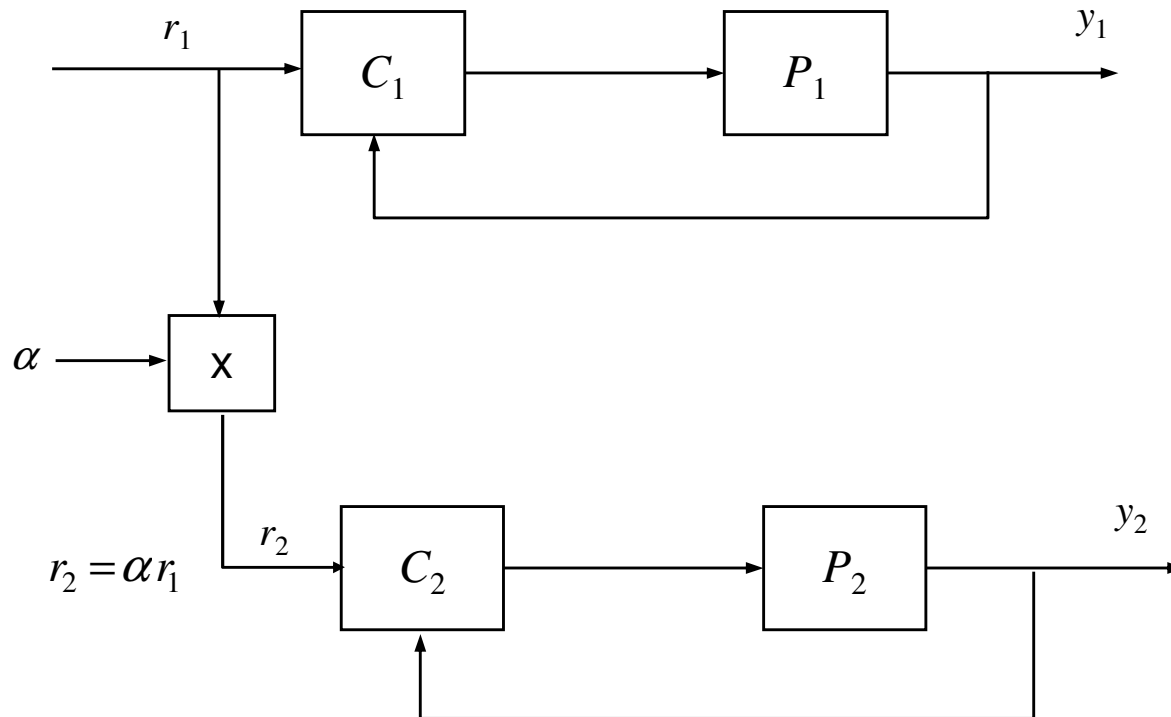

What are the disadvantages of this scheme?

# Test run: Ratio against SP

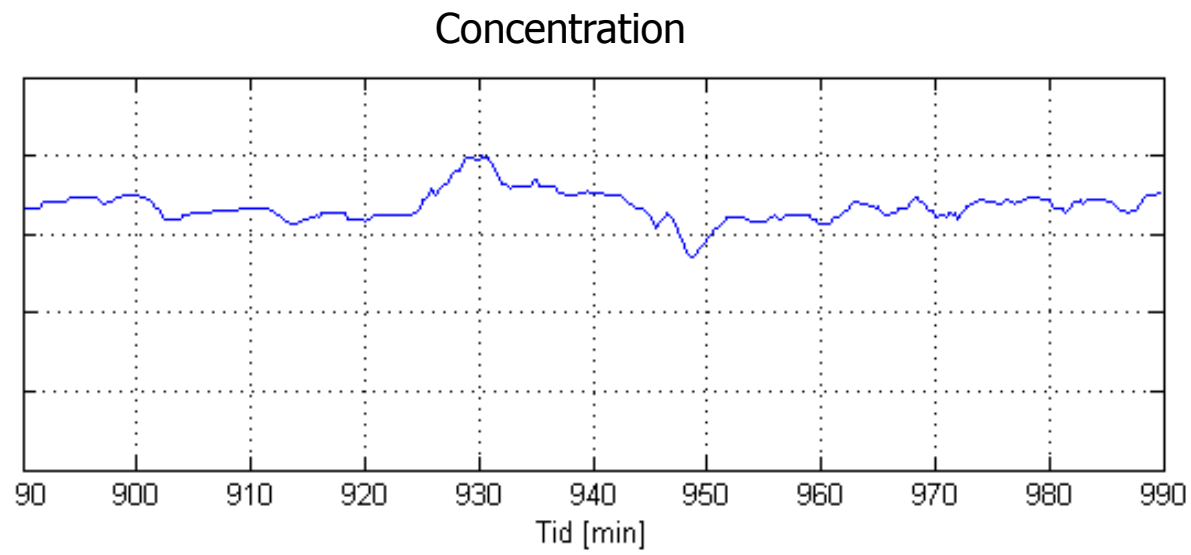
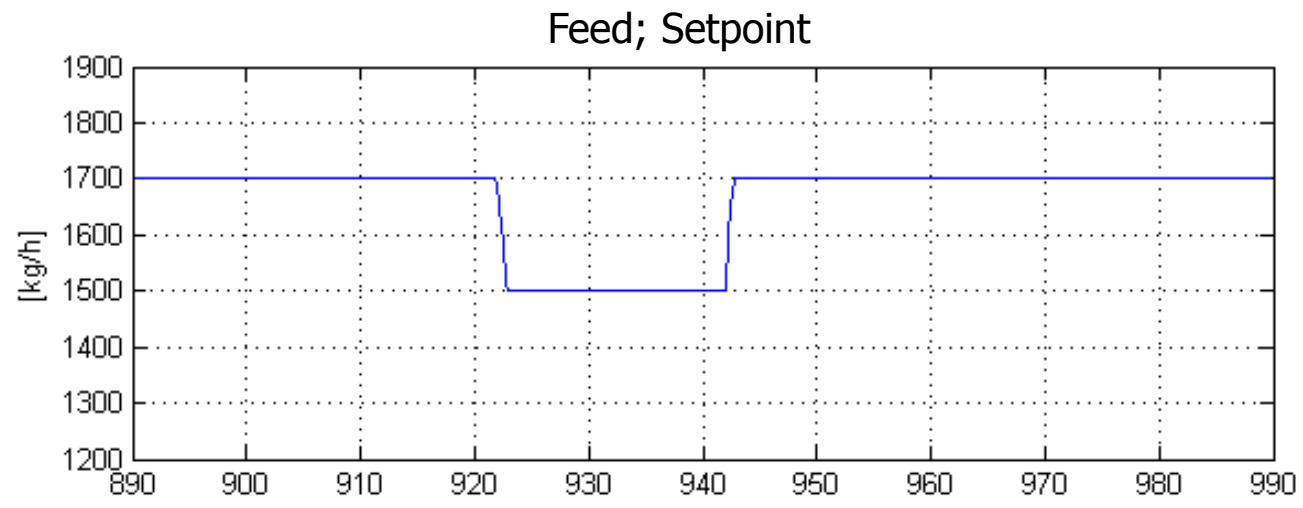

# New case

# Reactor control; Residual oxygen

- Process: Two phase oxidation reactor (liquid-oxygen)
  - On-line measurement of residual  $O_2$  in reactor gas; must be controlled.
  - Which different control structures are feasible, and what are their respective advantages?

Liquid feed is master = TPM  
(determines production rate)

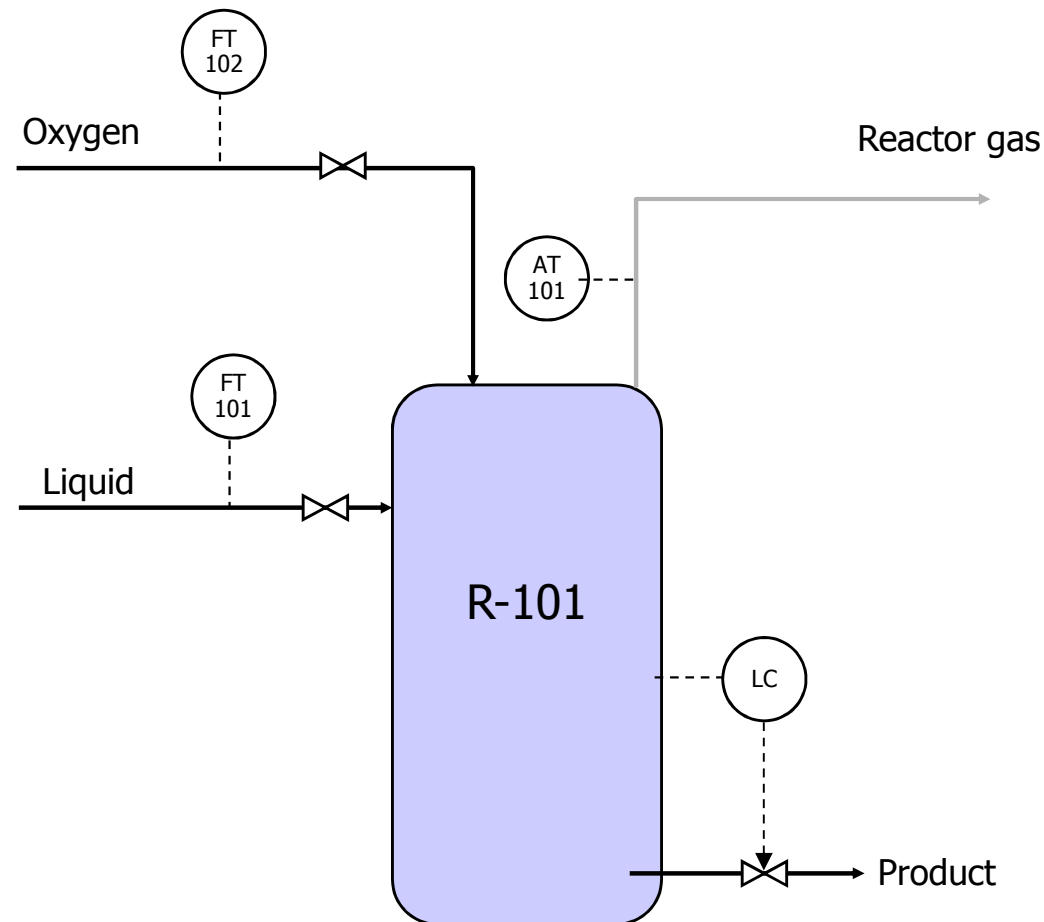

# Alternative 1: O<sub>2</sub>-feed in cascade against residual-O<sub>2</sub>

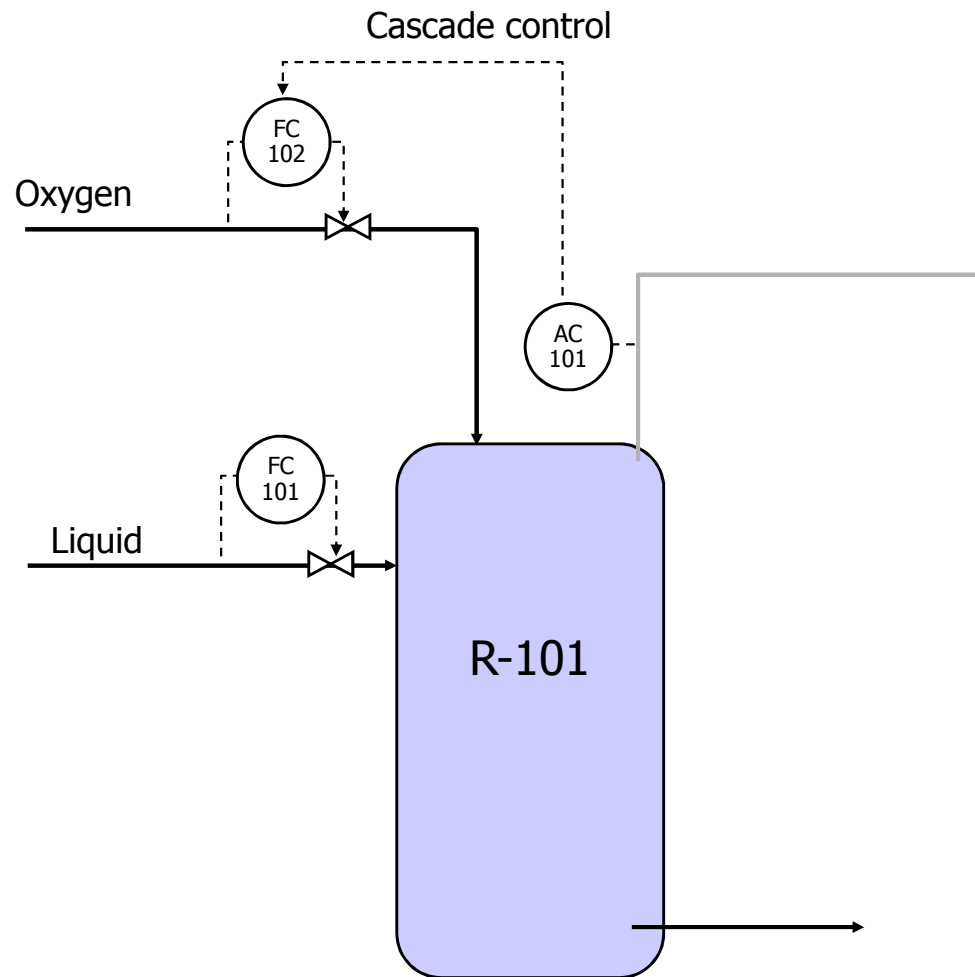

## Alt 2: O<sub>2</sub> feed in ratio against liquid, cascade against residual O<sub>2</sub>

This structure is superior if liquid feed varies, e.g. during a start-up.

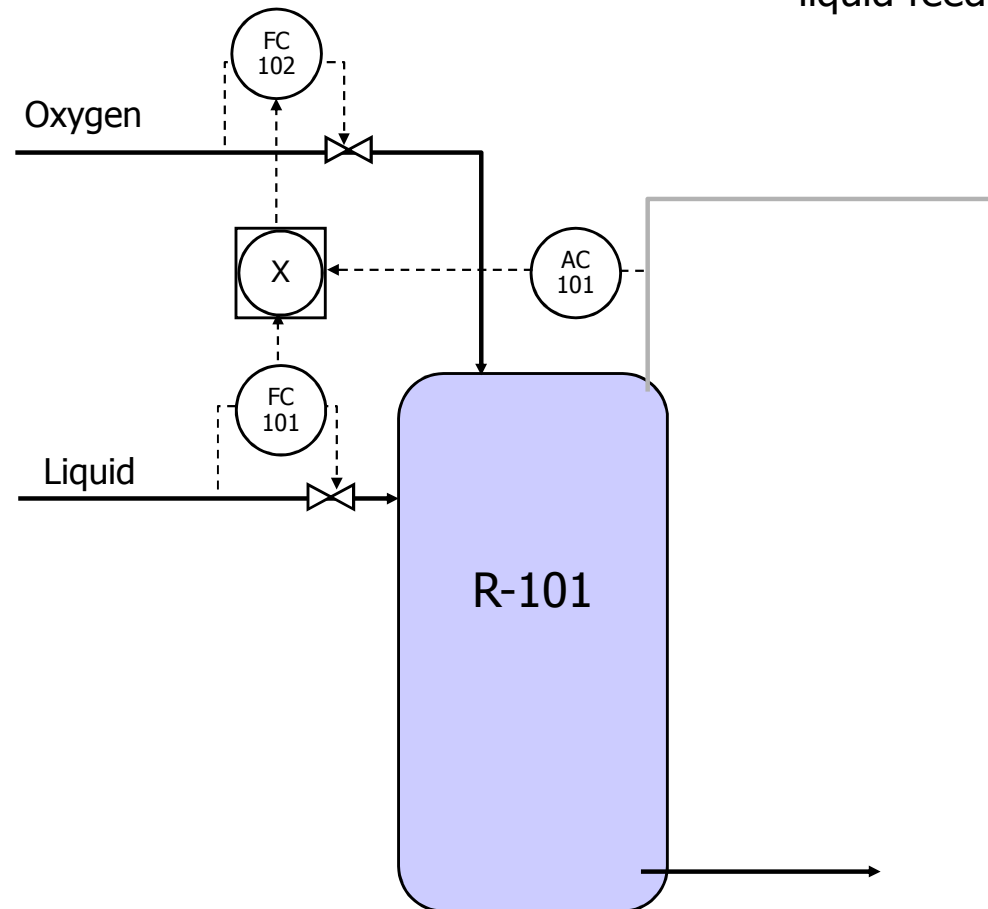

# New case



# Crystallizer: Level disturbance from wash sequence

- A crystallizer is automatically flushed with water, once every second hour. The water flow is large enough to affect level.
- It's important to keep a steady level.

## Improvement suggestions?

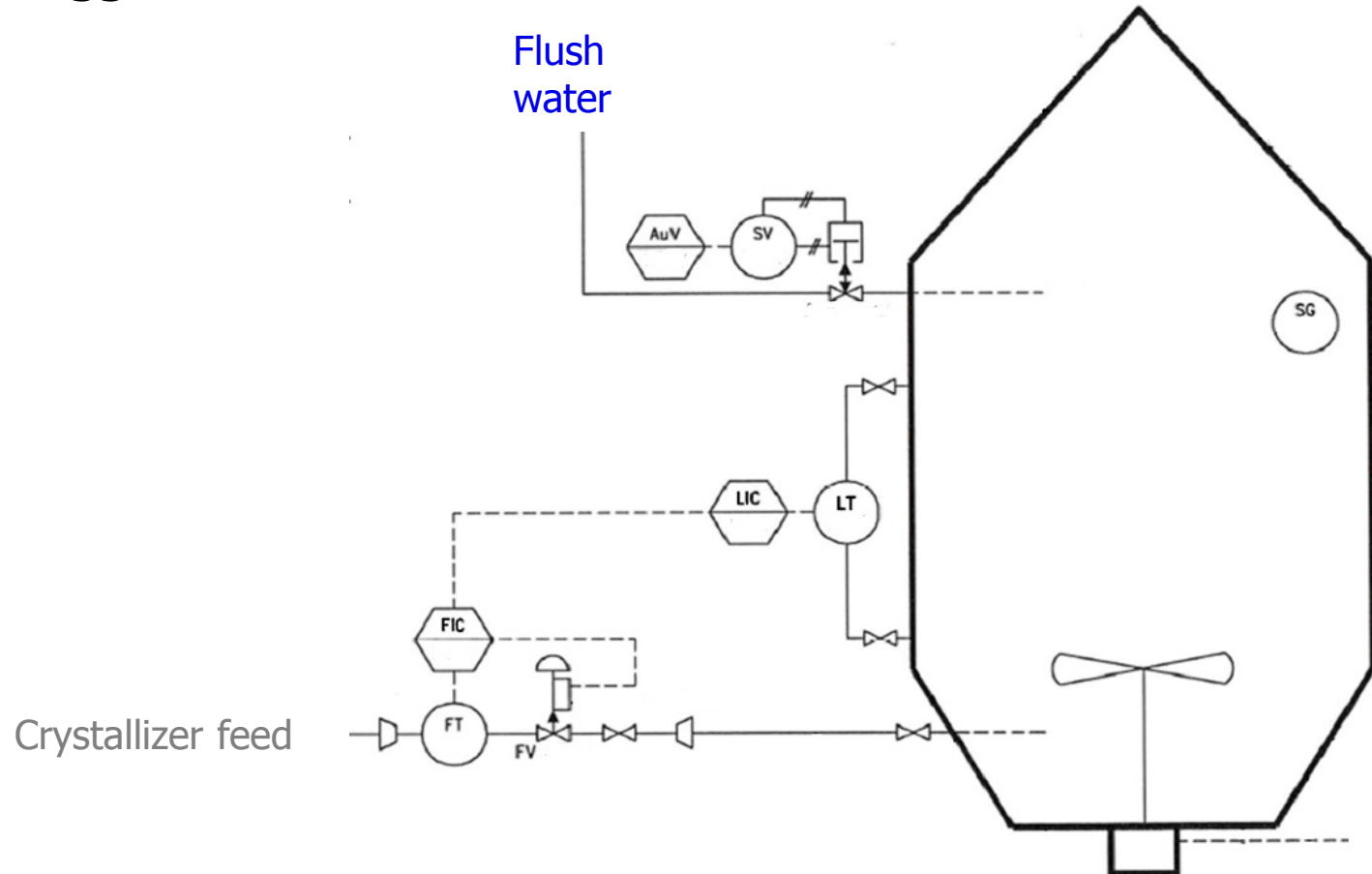

# Crystallizer: Feedforward reduces level variations

- A FF from on-off-valve to level controller reduces level variations.
- Thus, it's ok to make a FF from a discrete (binary) variable.

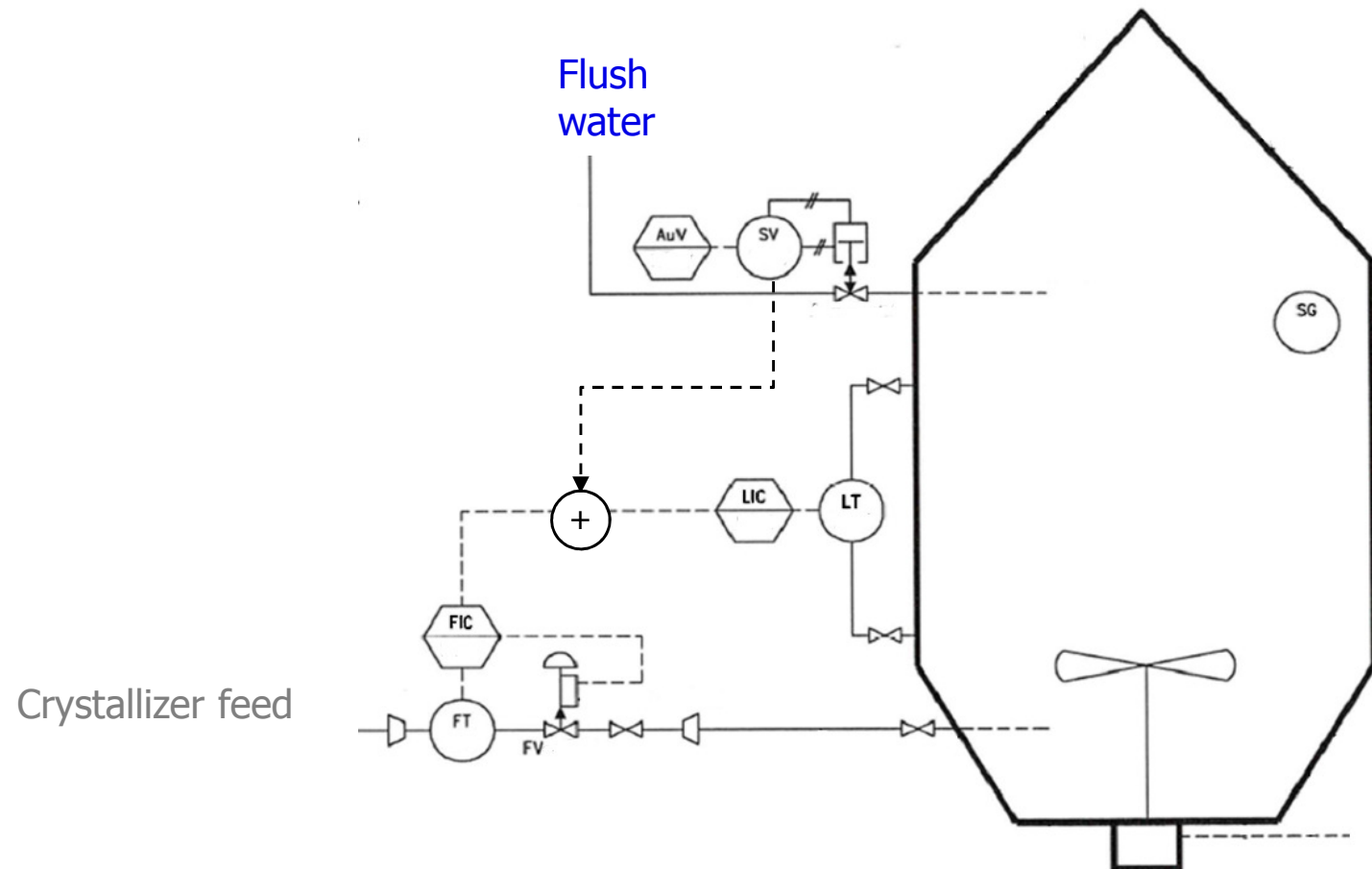

# Smaller level variations in crystallizer

Without feedforward from on-off valve

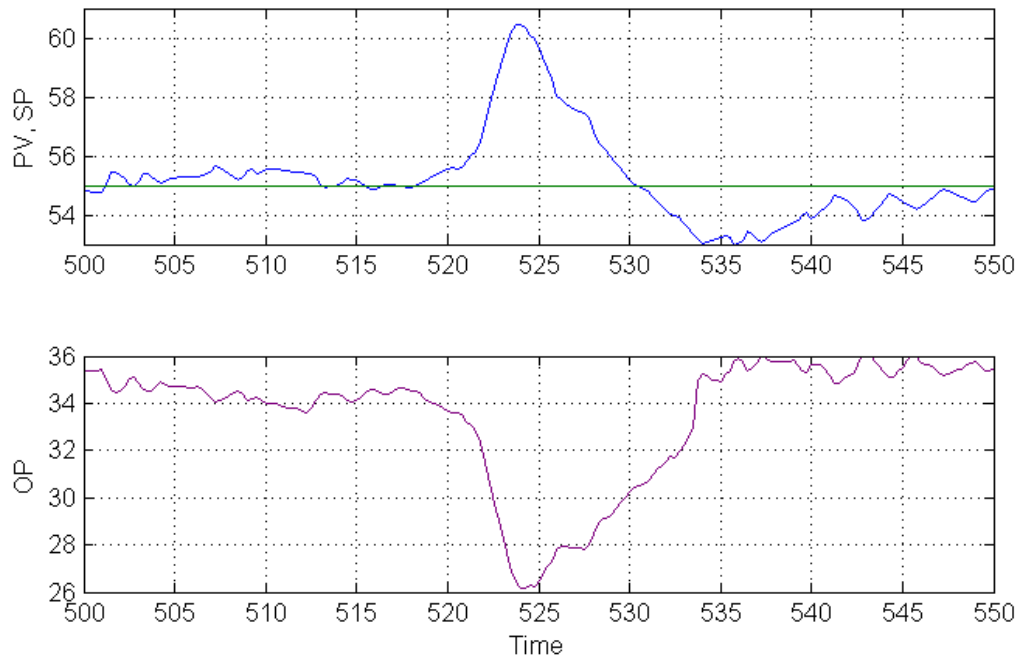

With feedforward

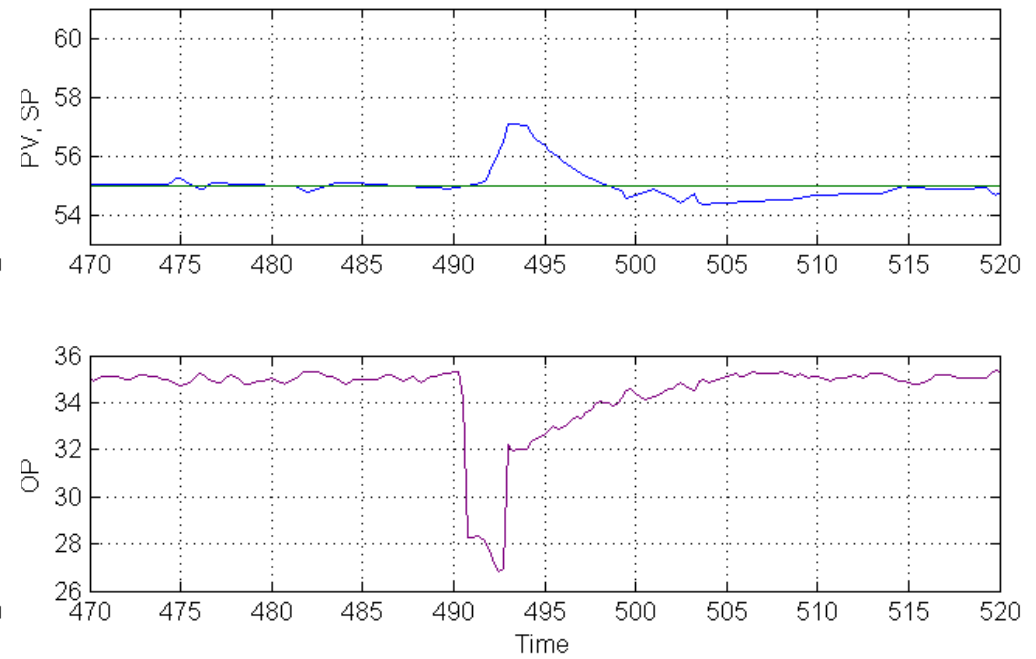

# Why don't we do the full compensation?

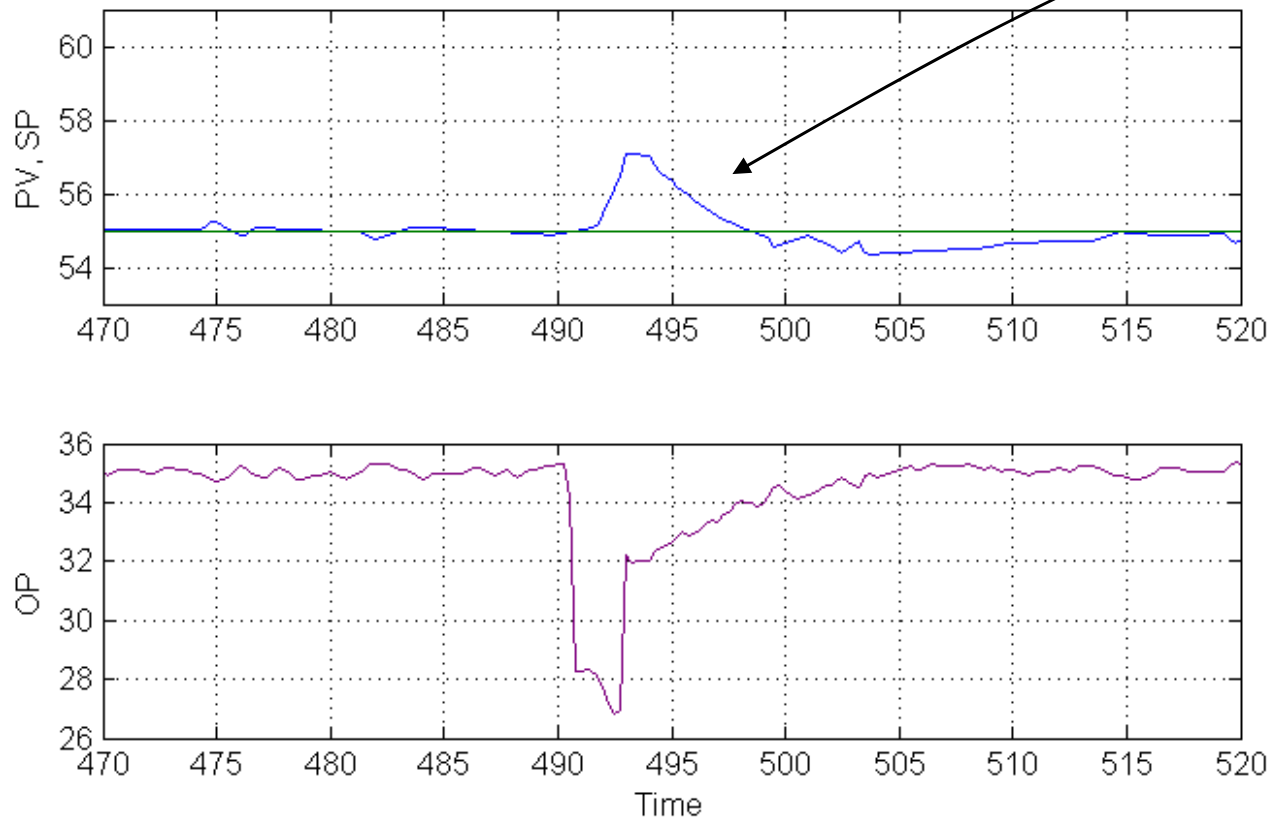

There us a residual level disturbance, because the feedforward gain used was only 0.8 of that calculated theoretically.

Why didn't we use the full gain for compensating?



# New case

# Sewer pH-control process

There are two valves for feeding caustic to the pit: a small, accurate one, and a larger coarse valve.

So we have one extra degree of freedom for controlling pH. How can we design a control scheme that utilizes this freedom in a good way?

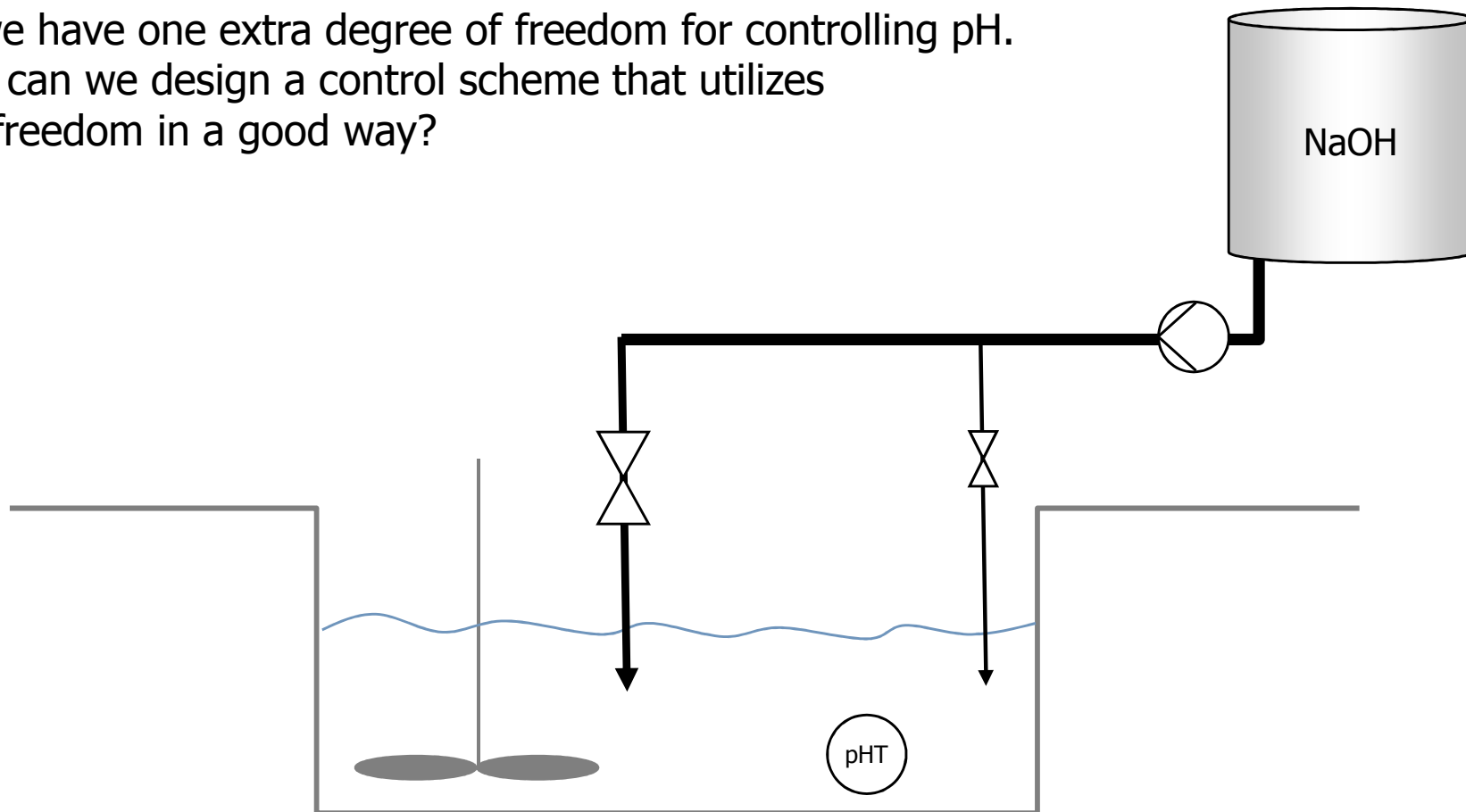

# Solution: Mid-ranging (valve position control)

Let a pH-controller manipulate the small valve

Introduce a valve position controller (VPC) which controls the position of the small valve by slowly adjusting the large valve (working through the process).

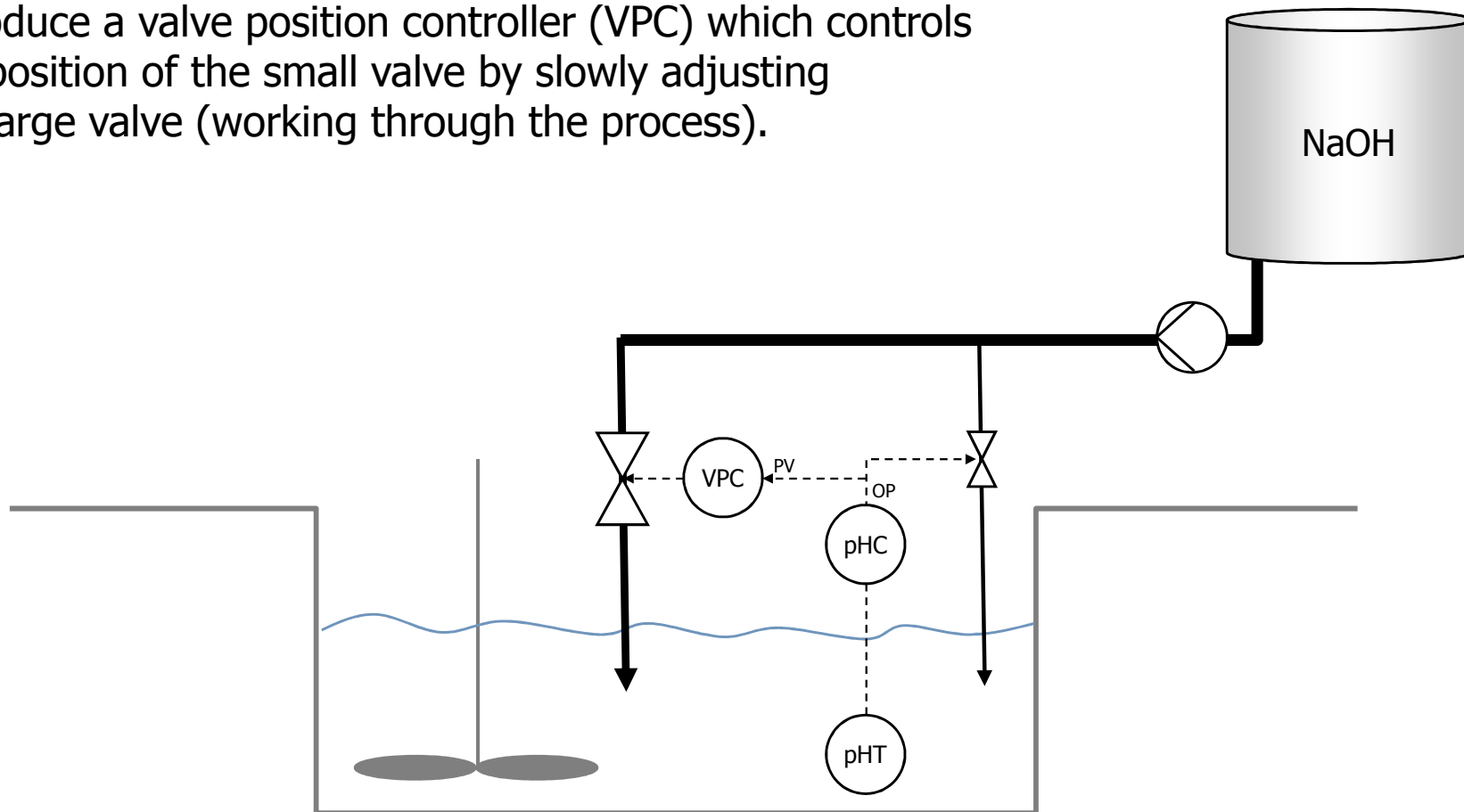

# Block schedule for MR-control: Give setpoint for $u_1$

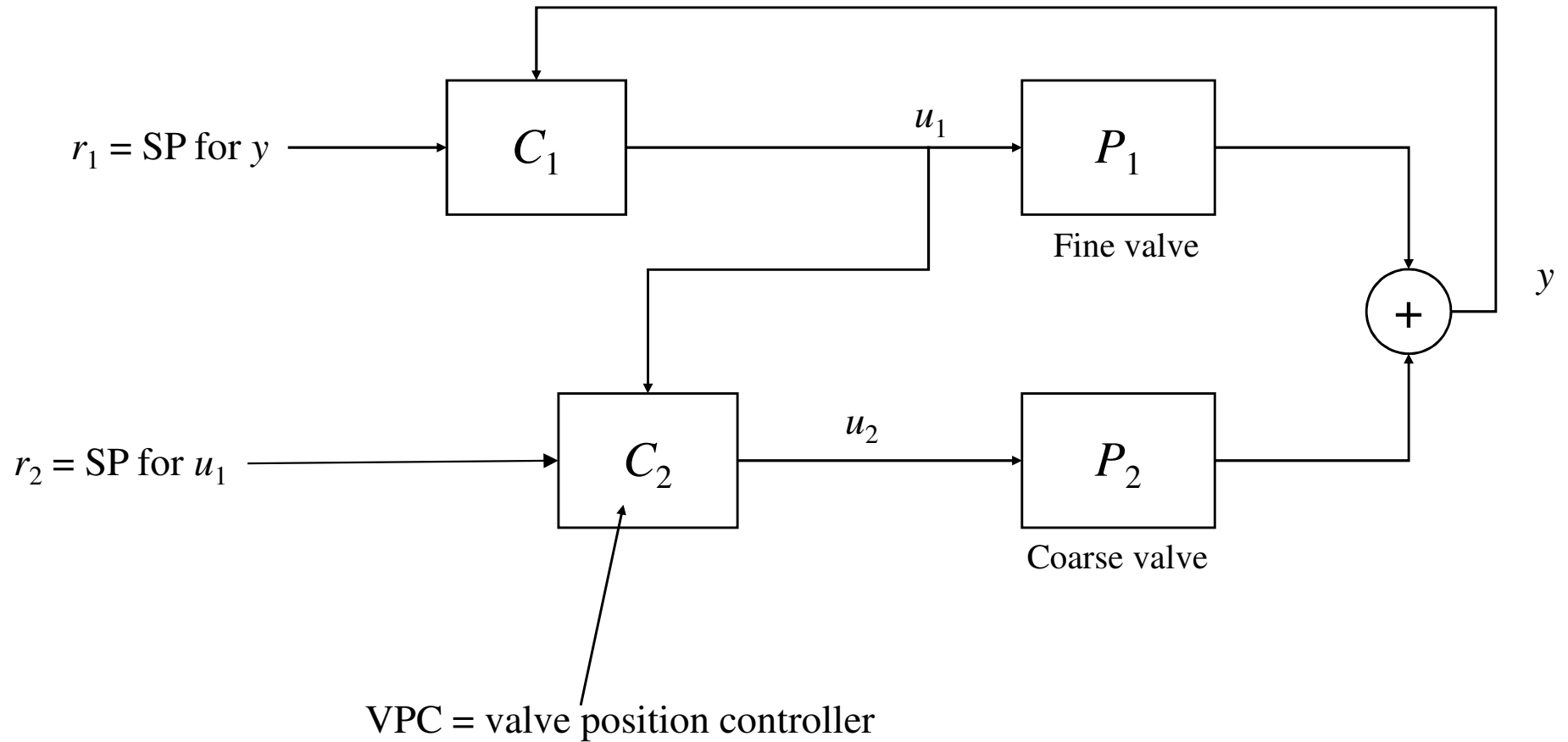



# pH control; Results

pH: Daily averages before and after new control structure

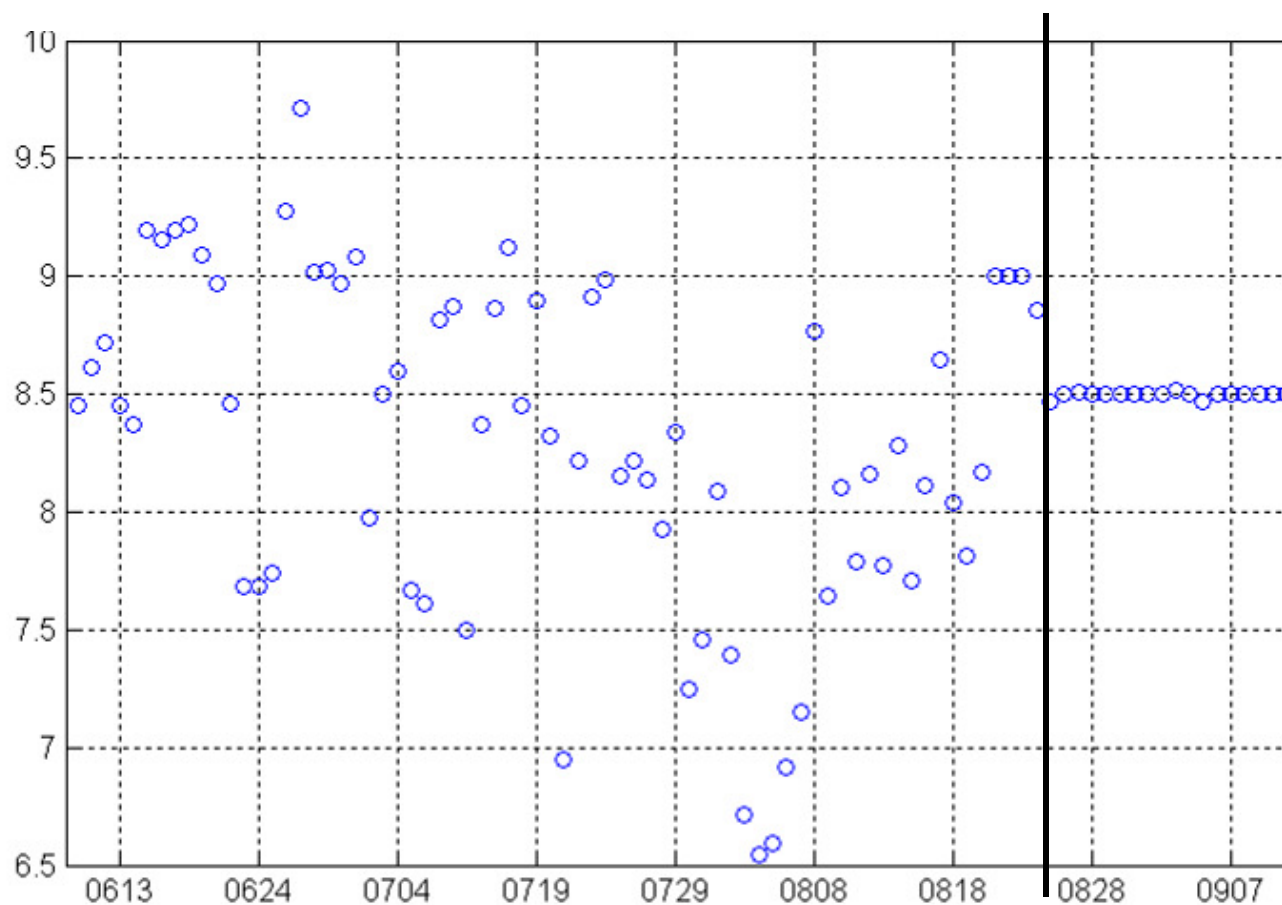

# Improved pH-control gives fewer alarms

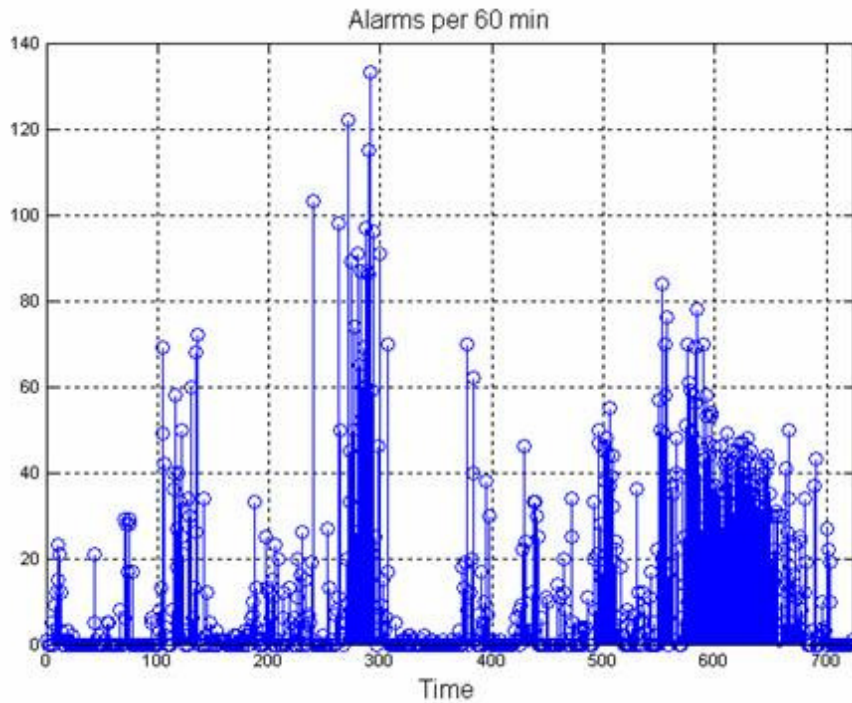

Before: 10 488 alarms in one month

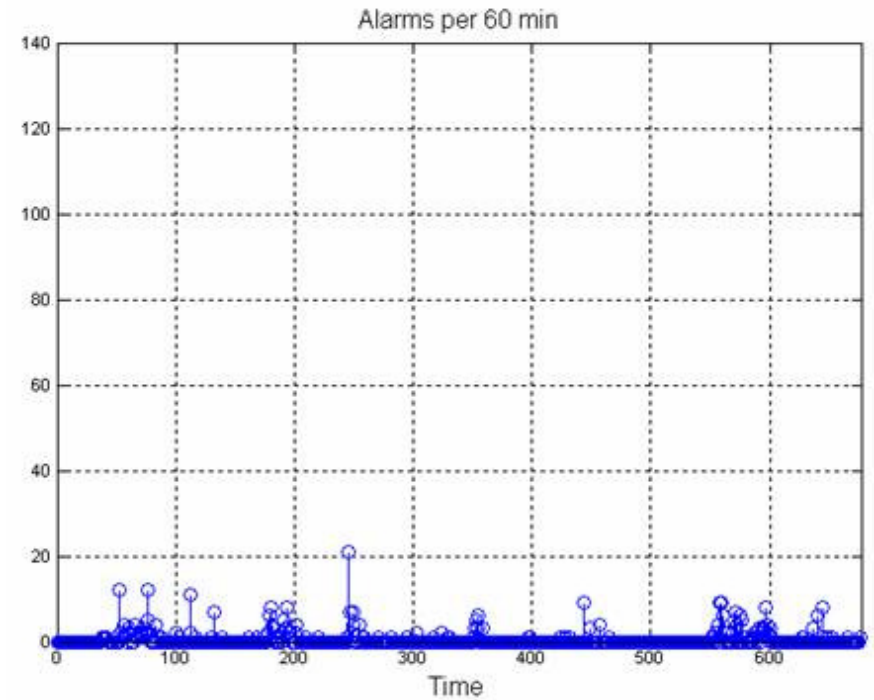

After: 418 alarms in one month

96% fewer alarms from this object.

# New case

# Exothermic reactor temperature control

The reactor solution is circulated through a heat exchanger (cooler).  
The reaction is very exothermic: it is important to control the temperature.  
Typical variations/disturbances: Cooling water header pressure, CW temperature

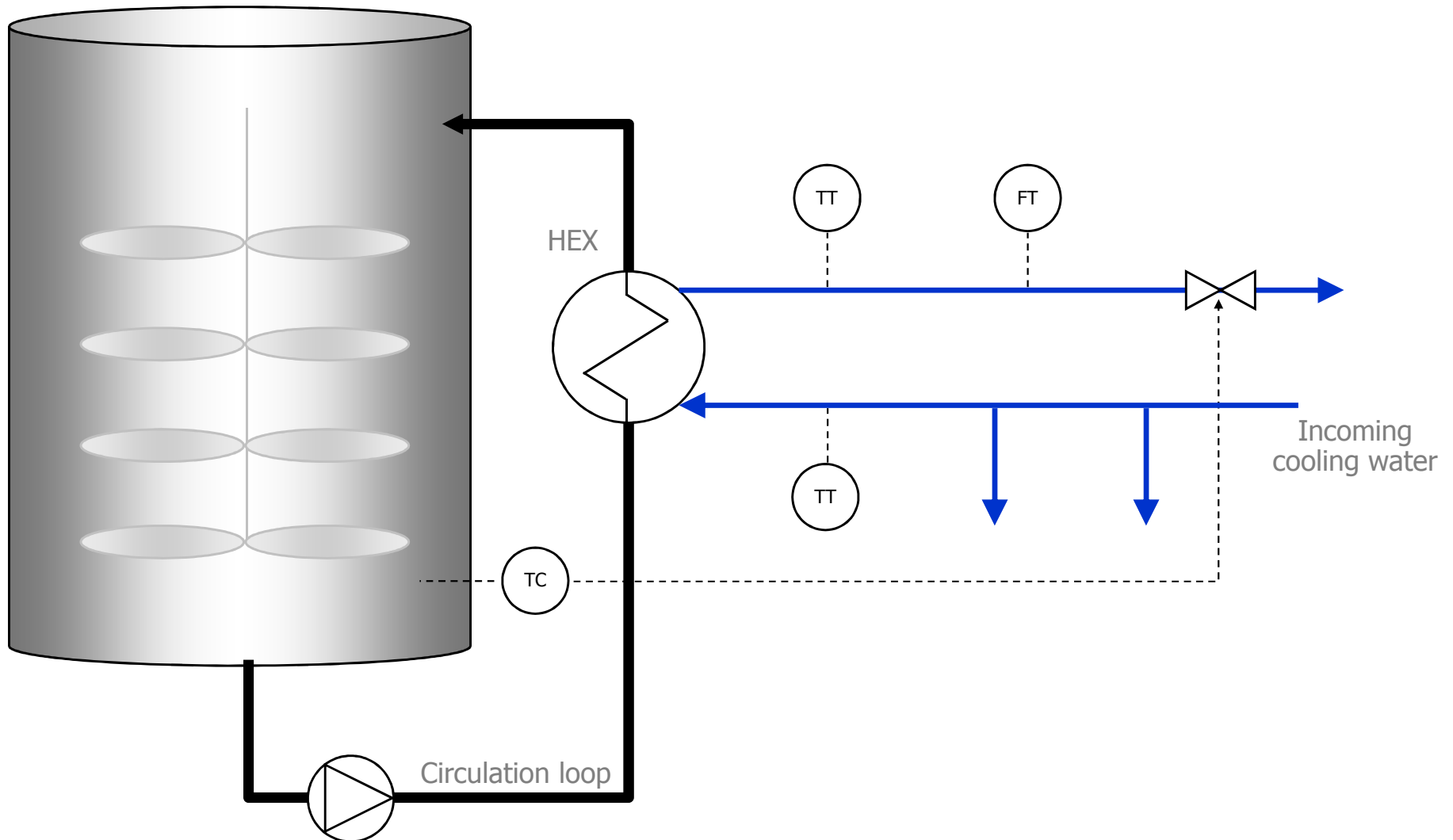

# New control structure: Power control

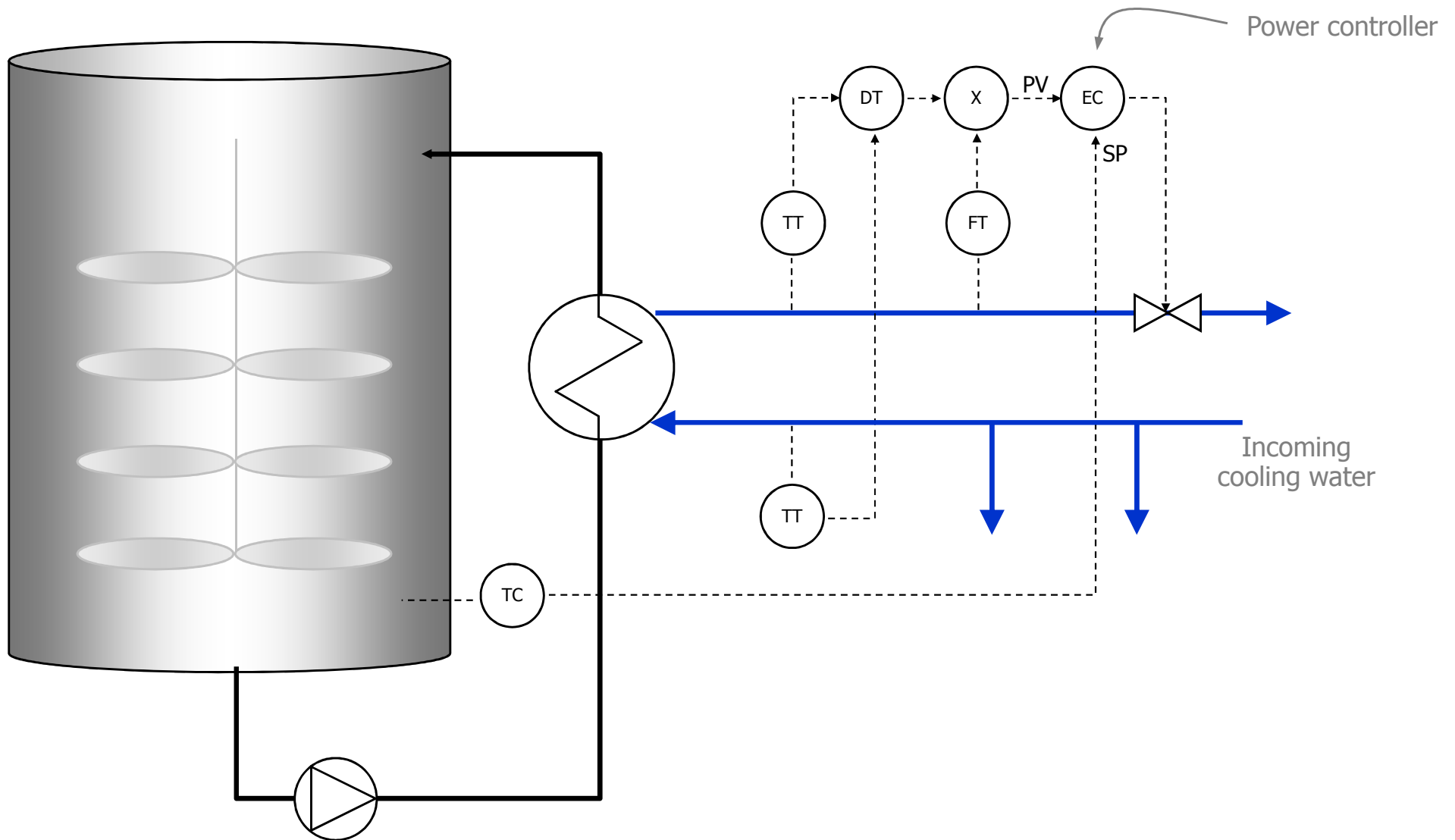

# HEX power control reduces variations between batches

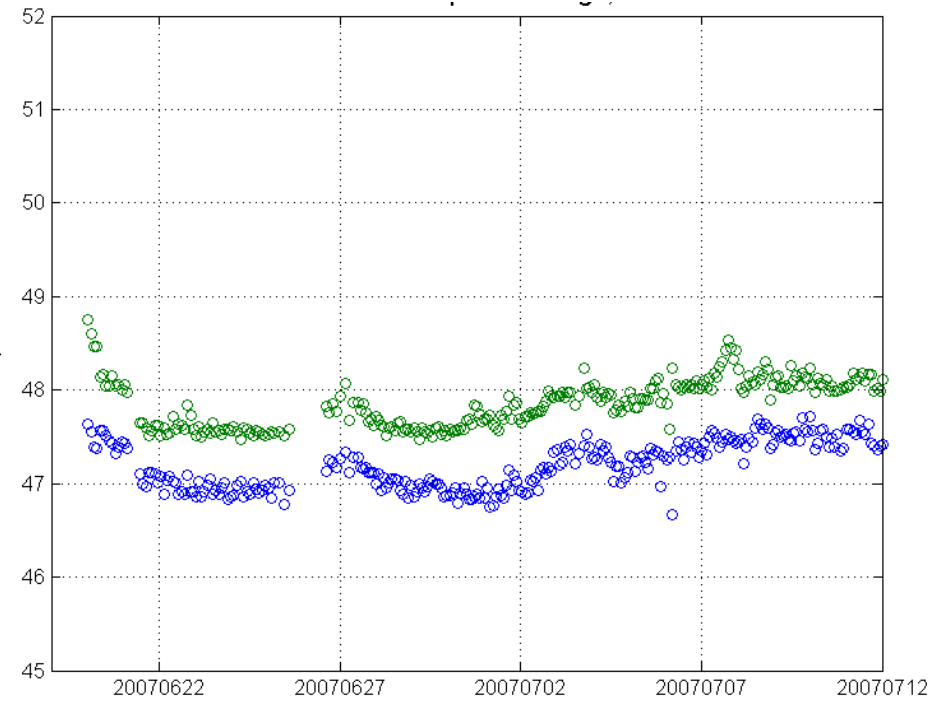
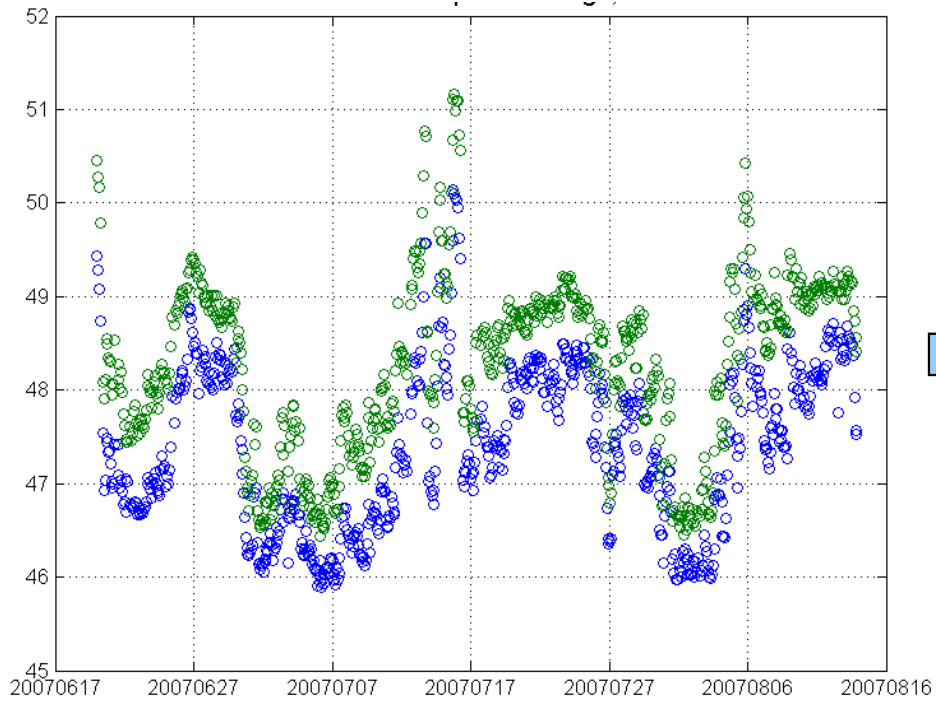

# New case

# Two step dilution: how to use the extra DoF?

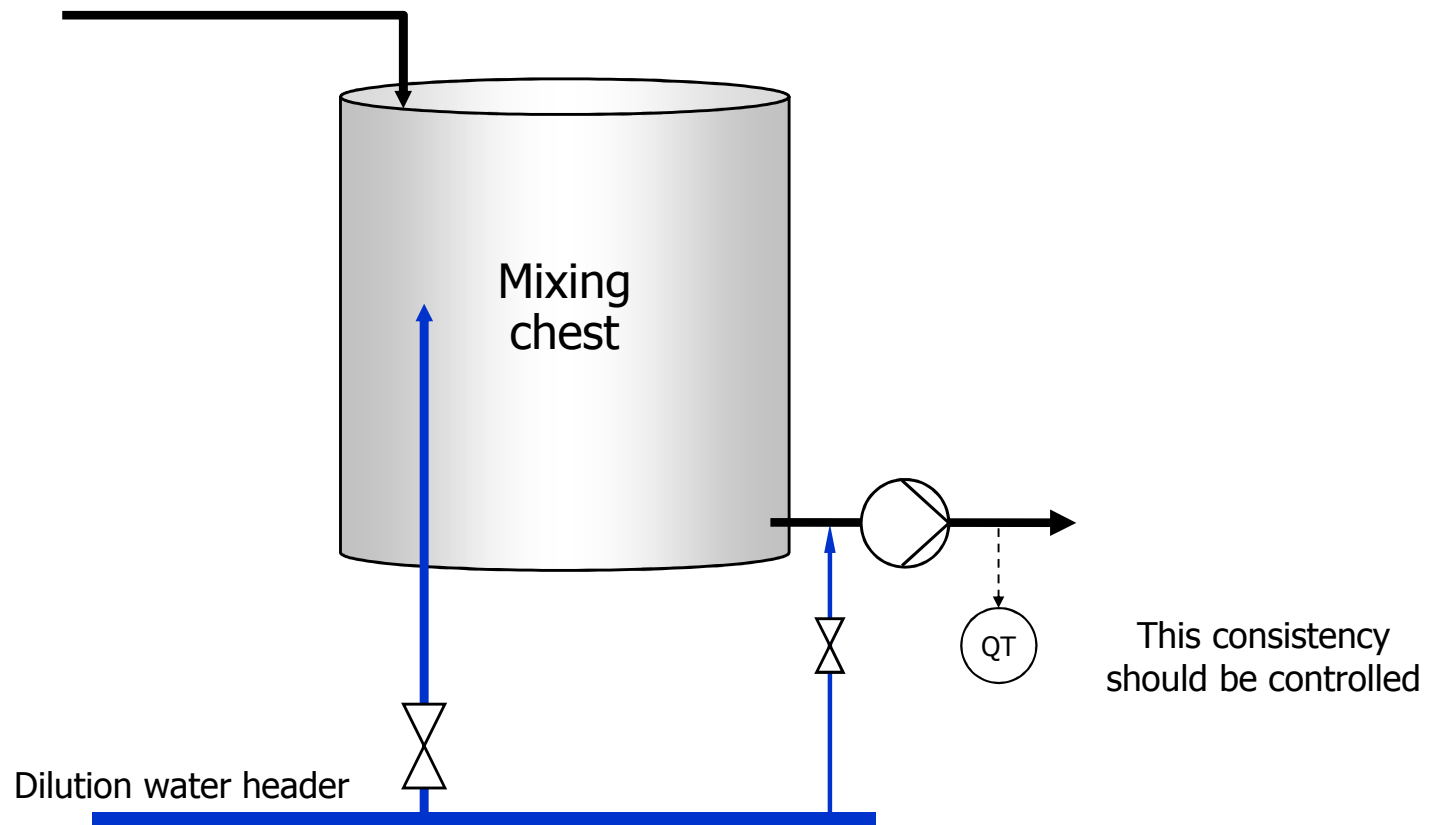



# Two step dilution = Typical case for mid-ranging

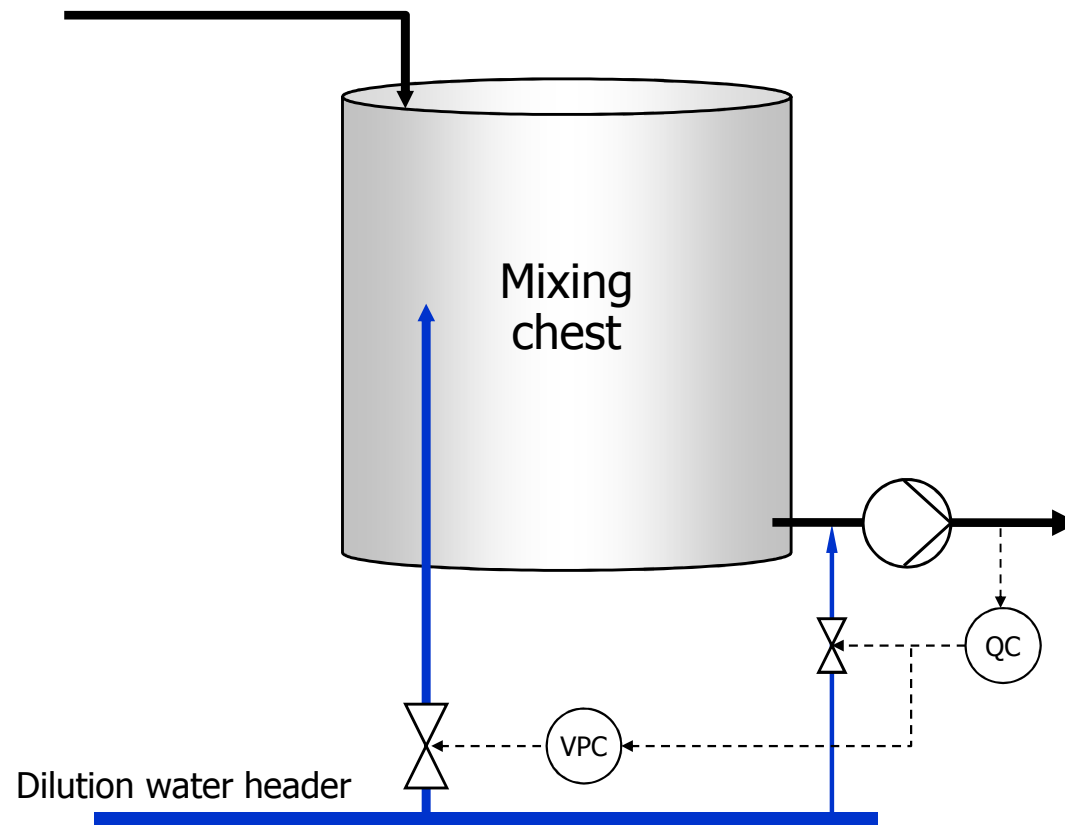

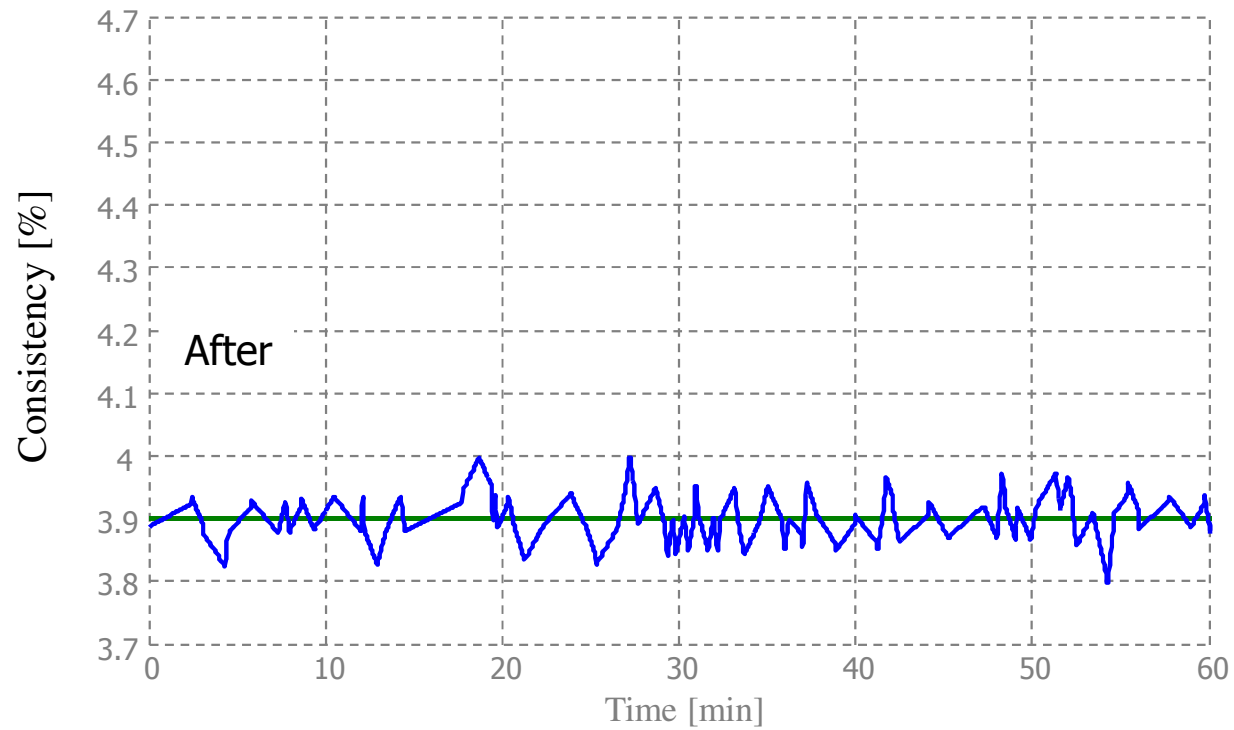
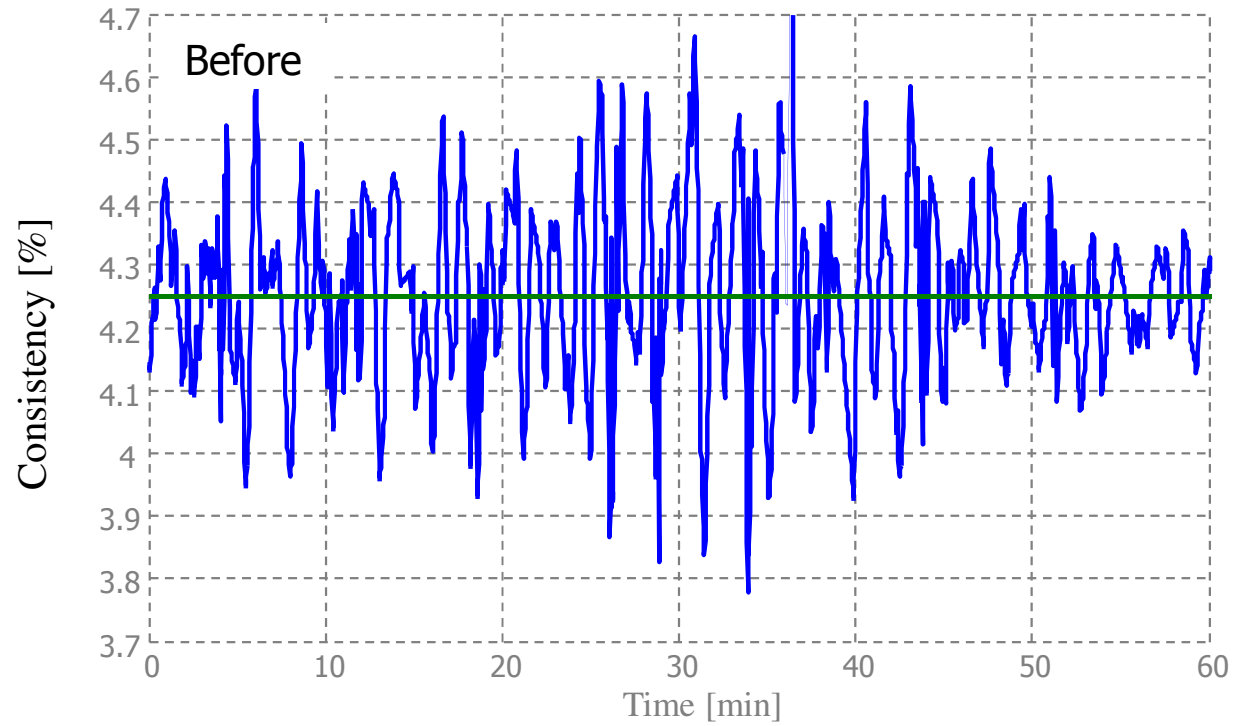

# Another example from pulping: HD tower

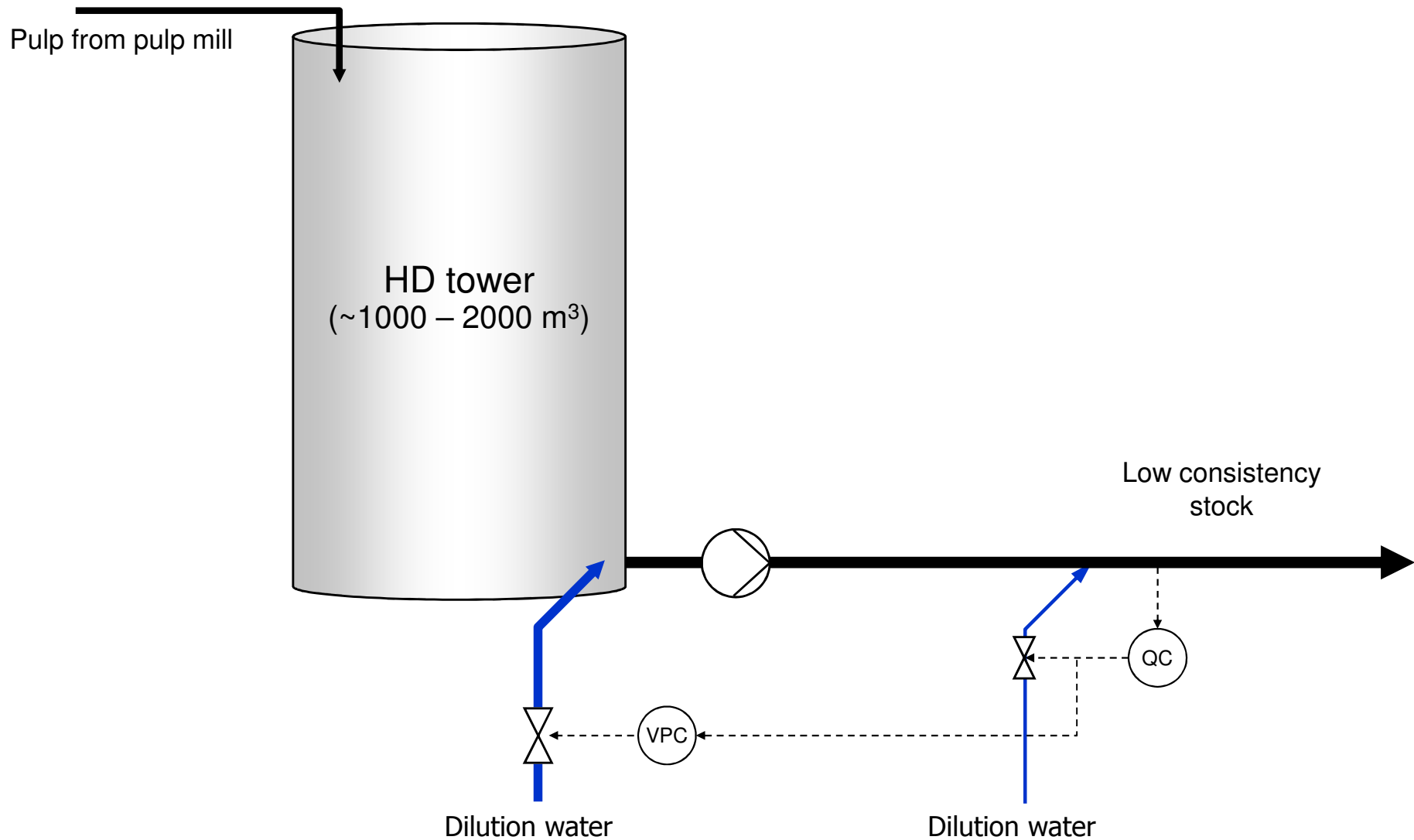

# New case

# pH control

- The purpose of this process is to stabilize the pH in the solution coming out of the tank.
  - Manipulate the caustic added to the feed line. Don't care about the level.
  - All variation comes from the pH of the feed solution
- Which pH-meter should be controlled in feedback?
- Is there a control structure better than just PID control?

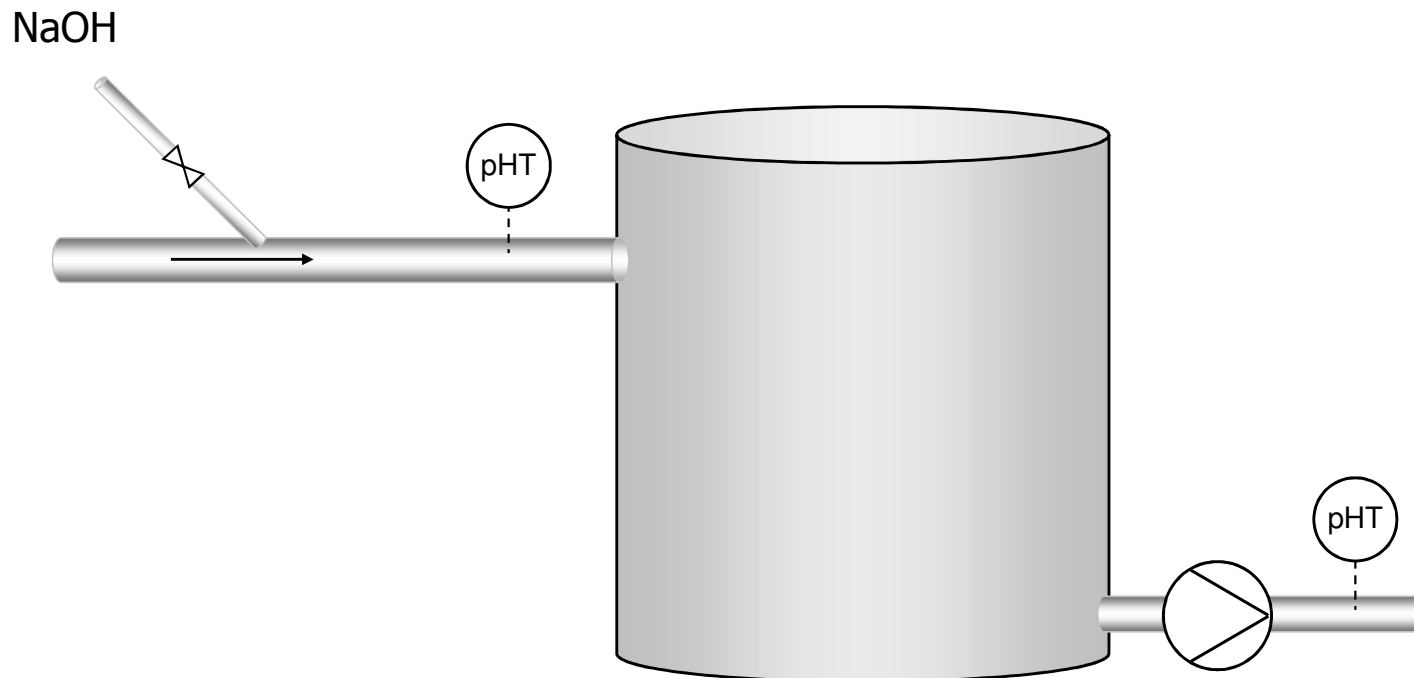

# The worst solution

- The solution below will give the highest variations in pH out of the tank.
- Since the meter is far away from the MV the process has a long deadtime, so we have to tune the controller very defensively.

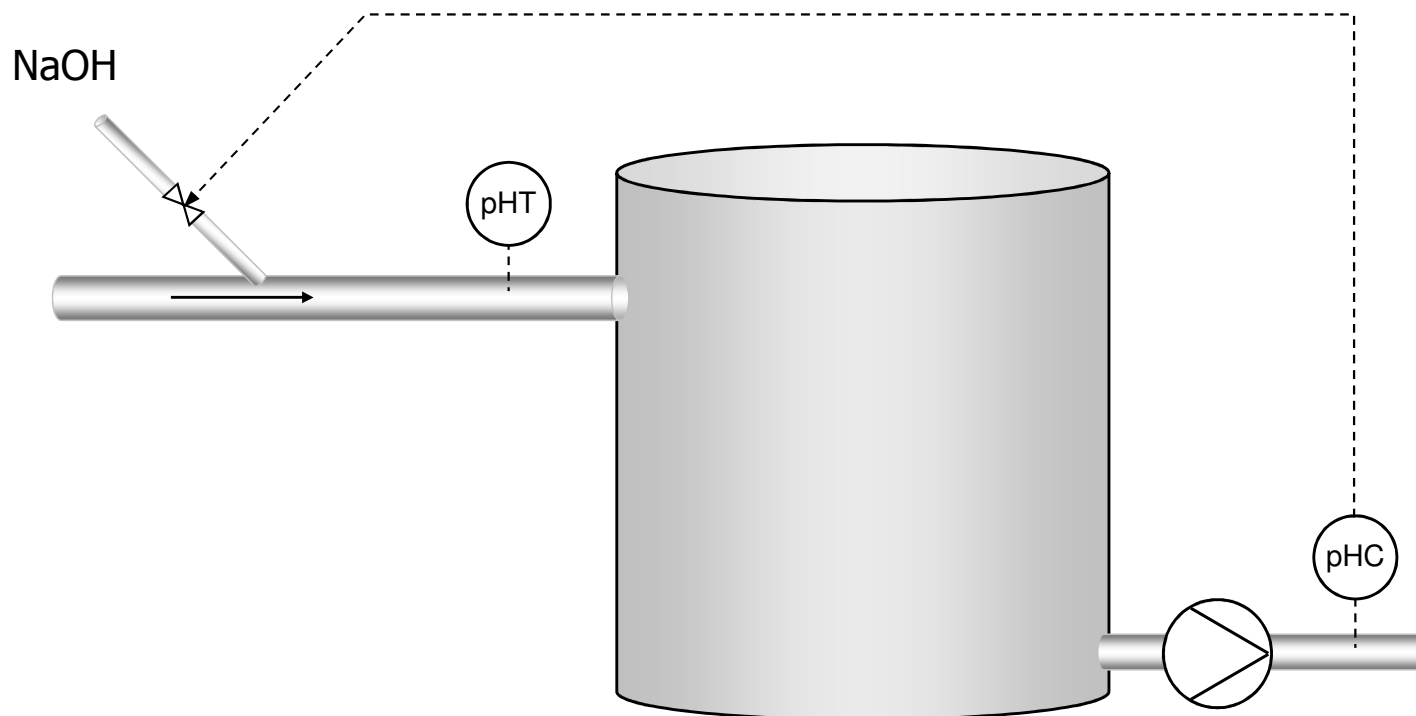

# Better

- This solution is much superior to the previous one. The controller can be tuned aggressively, since there is only a short delay.
- However, the final pH is not controlled here.

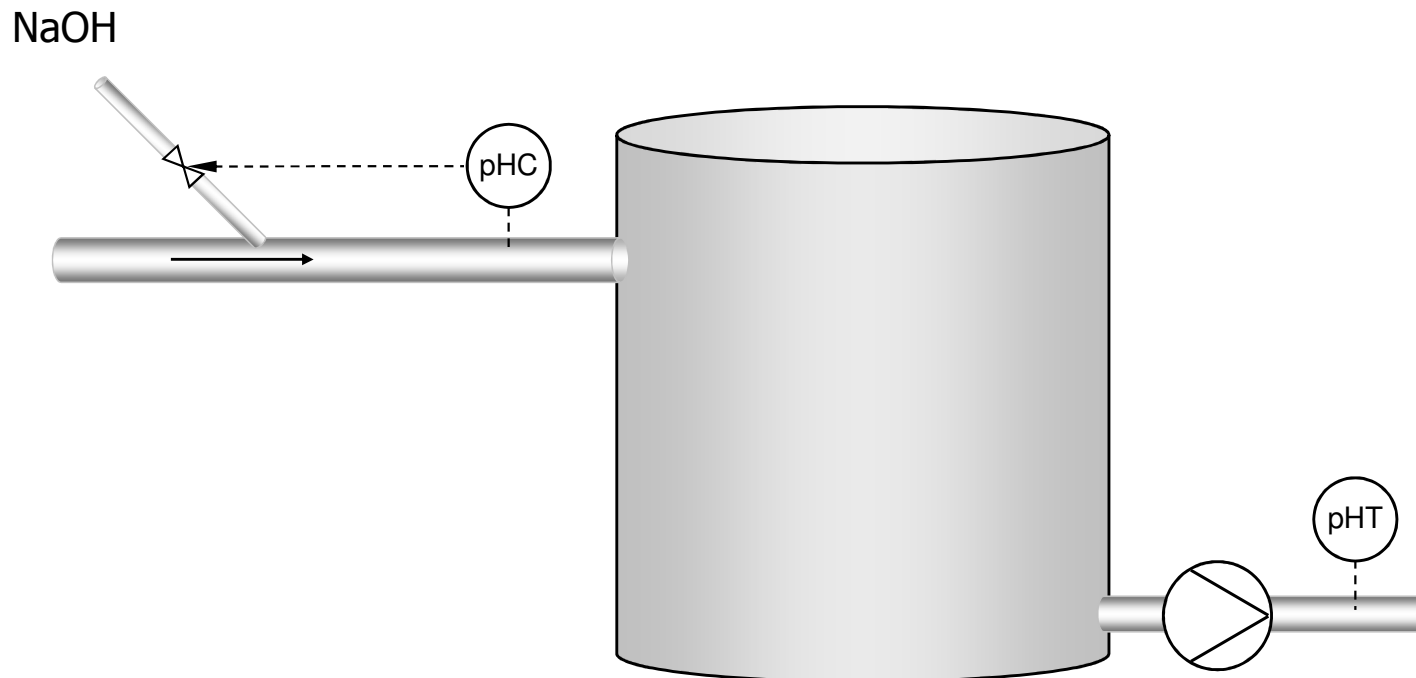

# Even better: Cascade control

- Can you argue why this solution is better than the first one (only local control)?

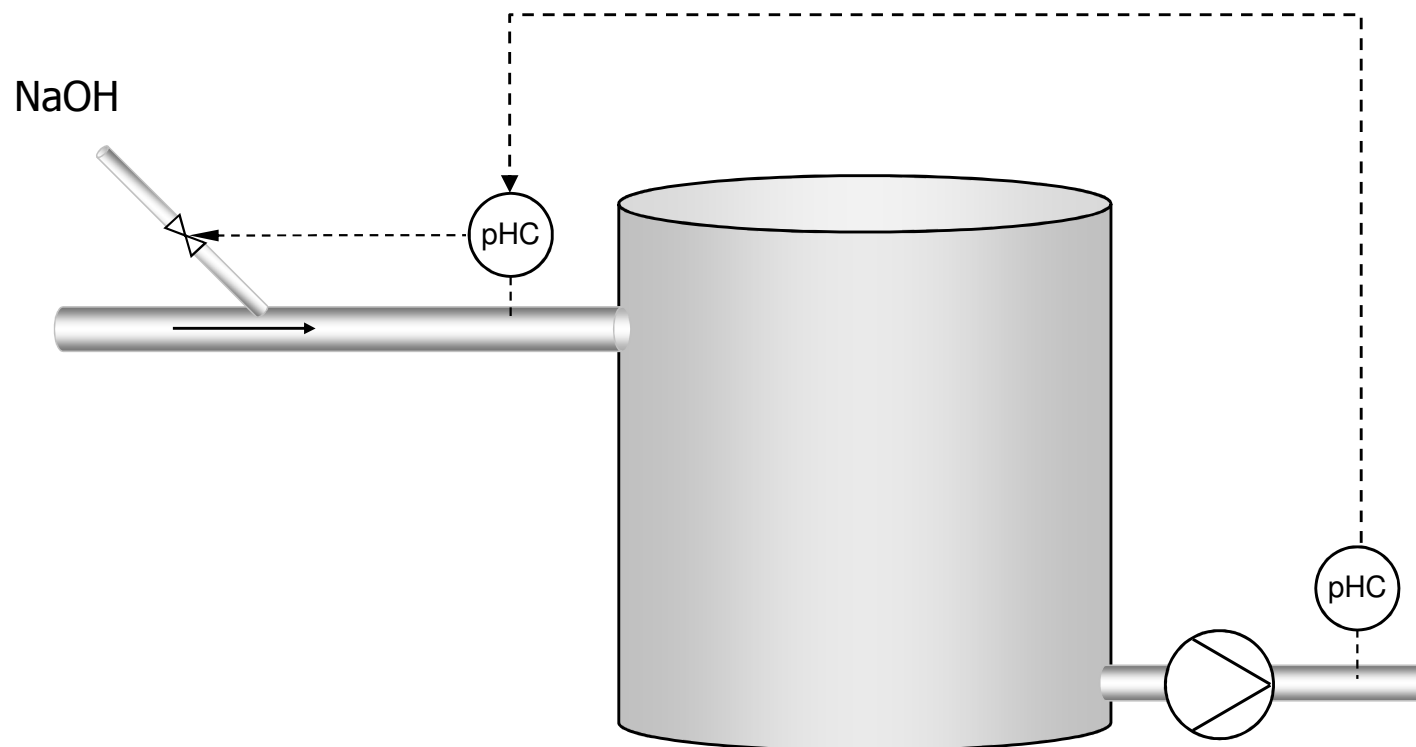



# Thank you!