

Stochastic Optimisation

Case study: hydrodesulfurization unit

Morten Aulin Moen

Department of Chemical Engineering
Norwegian University of Science and Technology

December 16, 2015

- 1 Stochastic Optimisation
 - Why use Stochastic Optimisation
 - Stochastic optimisation example
- 2 Case Study: hydrodesulfurization unit
 - Solution Method
 - Model Predictive Control
 - Results and conclusion

Why use Stochastic Optimisation

- Measurement error
- Uncertainties in some parameters
- Examples
 - Catalyst efficiency
 - Concentrations
 - Bubble size distribution
- More accurate back-off
- Average values can lead to instability

Stochastic Optimisation example

$$\begin{aligned} \min_{X_1, X_2} &= -X_1 - X_2 \\ \text{s.t.} \quad X_1 &= \tilde{b}_1 \\ X_2 &= \tilde{b}_2 \end{aligned} \quad (1)$$

$$(\tilde{b}_1, \tilde{b}_2) = \begin{cases} (3, 4) \\ (4, 3) \end{cases} \quad (2)$$

Stochastic Optimisation example

$$\begin{aligned} \min_{X_1, X_2} &= -X_1 - X_2 \\ \text{s.t.} \quad X_1 &= \tilde{b}_1 \\ X_2 &= \tilde{b}_2 \end{aligned} \quad (1)$$

$$(\tilde{b}_1, \tilde{b}_2) = \begin{cases} (3, 4) \\ (4, 3) \end{cases} \quad (2)$$

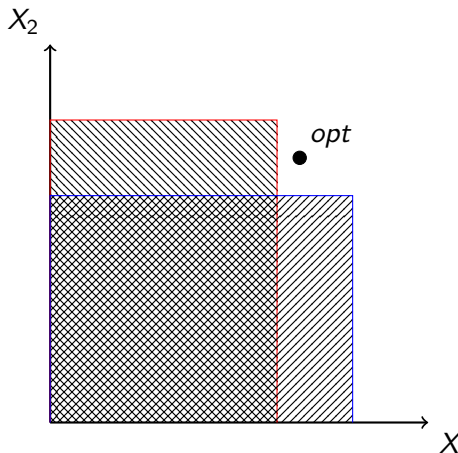

flow diagram of the hydrodesulfurization unit

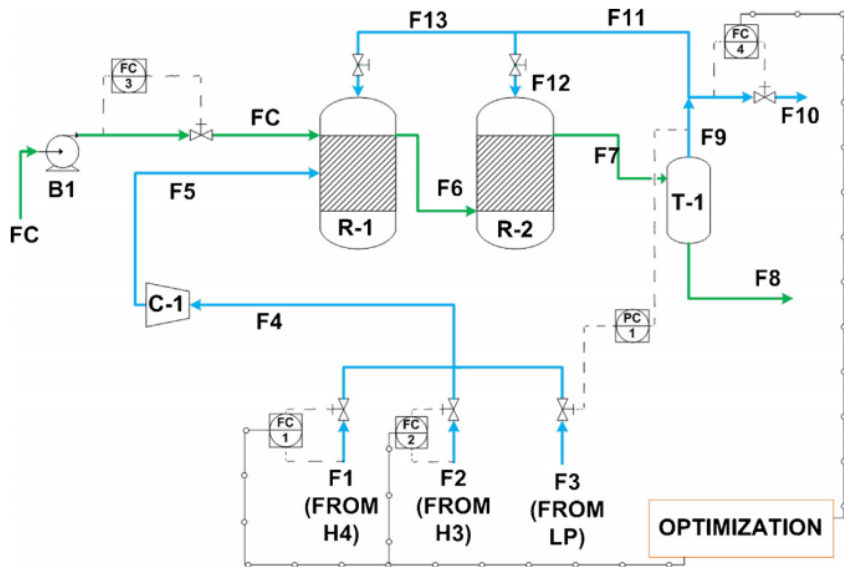

Chance Constraint method for solving stochastic optimisation

- Hold constraint with some probability
- Exclude extreme outcomes
- No increase of variables
- Probability distribution must be given
- Chance Constraint:

$$P(X_{H2}^{lb} \leq X_{H2}) \geq \alpha_{X_{H2}}, \quad P(X_5^{lb} \leq X_5) \geq \alpha_{X_5} \quad (3)$$

Monte Carlo simulation

- Find probability distribution of X_{H2} and X_5
- Solve the deterministic problem first
- Run Monte Carlo simulation
- Normal distribution fitting

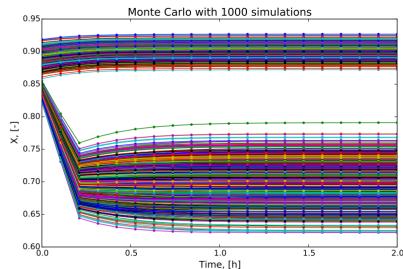

Normal Distribution fitting

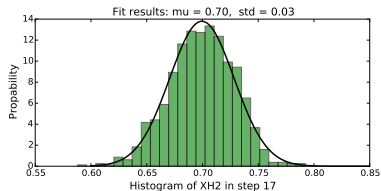
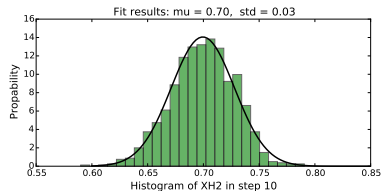
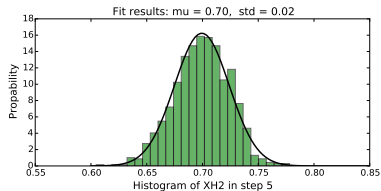
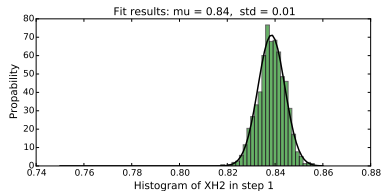

Number of constraint violations

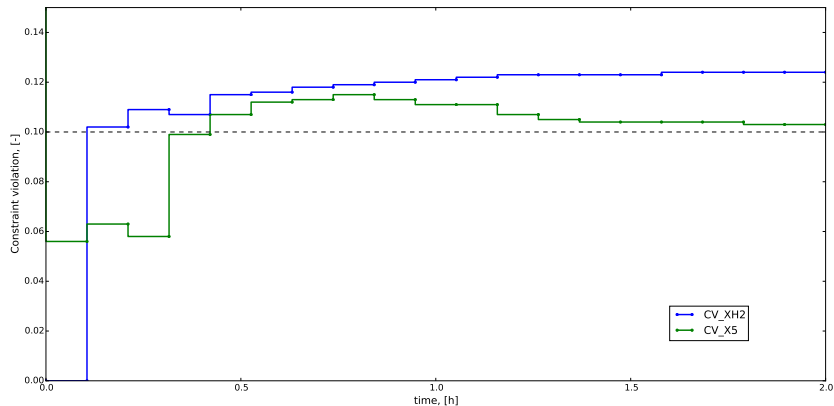
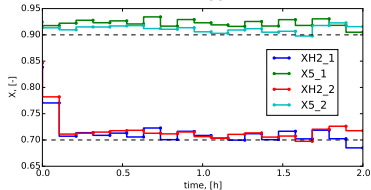
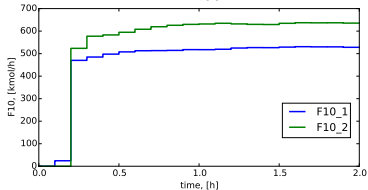
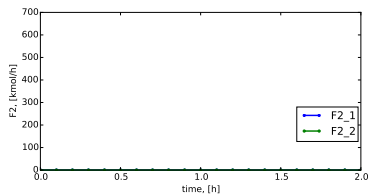
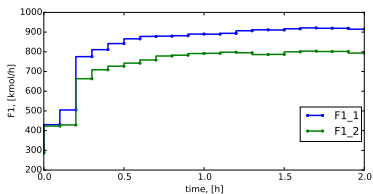

Figure:

- Offline optimisation: Blue Line, (.1)
- Online optimisation: Green Line, (.2)



Different optimisation tactics for MPC

Optimisation type	# Monte Carlo	Computational time [s]	Cost [euros]
Offline	1000	245	1522
Online	1000	2100	1329
Online	100	470	1346

Conclusion

- Stochastic optimisation can handle uncertainties
- Not normal distribution of the outcome
- Online optimisation best
- Online optimisation takes to long