

SOLUTION MANUAL PART 1: STAR-NUMBERED EXERCISES¹

Multivariable feedback control - Analysis and design

Sigurd Skogestad

Norwegian University of Science and Technology

Ian Postlethwaite

University of Leicester

JOHN WILEY & SONS

Chichester · New York · Brisbane · Toronto · Singapore

¹ The solution manual was prepared by Yi Cao, Vinay Kariwala, Eduardo Shigueo Hori and Sigurd Skogestad

This version prepared October 2, 2007

2

CLASSICAL FEEDBACK CONTROL

Exercise 2.1 Use (2.36) to compute K_u and P_u for the process in (2.31).

Note:

$$G(s) = \frac{3(-2s + 1)}{(5s + 1)(10s + 1)}. \quad (2.31)$$

$$K_u = 1/|G(j\omega_u)|, \quad P_u = 2\pi/\omega_u \quad (2.36)$$

where ω_u is defined by $\angle G(j\omega_u) = -180^\circ$.

Solution. According to (2.31), the following equation can be obtained:

$$\angle G(j\omega_u) = \tan^{-1}(-2\omega_u) - \tan^{-1}(5\omega_u) - \tan^{-1}(10\omega_u) = -180^\circ$$

Hence,

$$\tan(180^\circ + \tan^{-1}(-2\omega_u)) = \tan(\tan^{-1}(5\omega_u) + \tan^{-1}(10\omega_u))$$

leads to

$$-2\omega_u = \frac{5\omega_u + 10\omega_u}{1 - 50\omega_u^2}$$

which gives the solution of

$$\omega_u = \frac{\sqrt{17}}{10}$$

and

$$K_u = \frac{1}{|G(j\frac{\sqrt{17}}{10})|} = \sqrt{\frac{(1 + 25 \times 17/100)(1 + 100 \times 17/100)}{9(1 + 4 \times 17/100)}} = 2.5$$

$$P_u = \frac{2\pi}{\omega_u} = \frac{20\pi}{\sqrt{17}} = 15.23$$

Exercise 2.3 Derive the approximation for $K_u = 1/|G(j\omega_u)|$ given in (5.96) for a first-order delay system.

Note: A first-order delay system can be represented by $G(s) = ke^{-\theta s}/(1 + \tau s)$, and

$$|G(j\omega_u)| \approx \frac{2}{\pi} k \frac{\theta}{\tau} \quad (5.96)$$

Solution.

$$\angle G(j\omega_u) = -\theta\omega_u - \angle(1 + j\omega_u\tau)^{-1} = -\pi$$

Assume $\tau \gg \theta$. Then $\omega_u\tau \gg 1$ and $\angle(1 + j\omega_u\tau)^{-1} \approx -\pi/2$. Hence, $\omega_u \approx (\pi/2)/\theta$ and

$$K_u = \frac{1}{|G(j\omega_u)|} \approx \frac{\tau\omega_u}{k} \approx \frac{\pi\tau}{2k\theta}$$

3

INTRODUCTION TO MULTIVARIABLE CONTROL

Exercise 3.1 Derive the cascade and feedback rules.

Solution.

Cascade rule As shown in Fig. 3.1(a), let the signal from G_1 to G_2 be x , then $z = G_2x$ and $x = G_1u$, thus, $z = G_2G_1u = Gu$, i.e. $G = G_1G_2$.

Feedback rule As shown in Fig.3.1(b), we have, $v = u + z = u + G_2y = u + G_2G_1v$, or, $(I - G_2G_1)v = u$. Let $L = G_2G_1$, we can obtain, $v = (I - L)^{-1}u$.

Exercise 3.3 Use the MIMO rule to show that (2.19) corresponds to the negative feedback system in Figure 2.4.

Solution. In Fig. 2.4, from point y the loop transfer function is KG and exiting the loop gives the term $(I + KG)^{-1}$. Therefore, the transfer function from r to y is $KG(I + KG)^{-1} = (I + KG)^{-1}KG$, from d to y is $(I + KG)^{-1}G_d$ and from n to y is $-(I + KG)^{-1}KG$. So (2.18) represents the negative feedback system in Fig. 2.4.

Exercise 3.5 Compute the spectral radius and the five matrix norms mentioned above for the matrices in (3.29) and (3.30).

Solution.

Matrix (3.29):

$$\begin{aligned} G_1 &= \begin{bmatrix} 5 & 4 \\ 3 & 2 \end{bmatrix} \\ \rho(G_1) &= 7.2749 \\ \|G_1\|_F &= 7.3485 \\ \|G_1\|_{\text{sum}} &= 14 \\ \|G_1\|_{i1} &= 8 \\ \|G_1\|_{i\infty} &= 9 \\ \|G_1\|_{i2} &= 7.3434 \end{aligned}$$

Matrix (3.30):

$$\begin{aligned} G &= \begin{bmatrix} 0 & 100 \\ 0 & 0 \end{bmatrix} \\ \rho(G) &= 0 \\ \|G\|_F &= \|G\|_{\text{sum}} = \|G\|_{i1} = \|G\|_{i2} = \|G\|_{i\infty} = 100 \end{aligned}$$

Exercise 3.7 Design decentralized single-loop controllers for the plant (3.65) using (a) the diagonal pairings and (b) the off-diagonal pairings. Use the delay θ (which is nominally 5 seconds) as a parameter. Use PI controllers independently tuned with the SIMC tuning rules (based on the paired elements).

$$G(s) = \frac{0.01e^{-5s}}{(s + 1.72 \cdot 10^{-4})(4.32s + 1)} \begin{bmatrix} -34.54(s + 0.0572) & 1.913 \\ -30.22s & -9.188(s + 6.95 \cdot 10^{-4}) \end{bmatrix} \quad (3.65)$$

Solution. For tuning purposes the elements in $G(s)$ are approximated using the half rule (see page 58) to get

$$G(s) \approx \begin{bmatrix} -0.0823 \frac{e^{-\theta s}}{s} & 0.01913 \frac{e^{-(\theta+2.16)s}}{s} \\ -0.3022 \frac{e^{-\theta s}}{4.32s+1} & -0.09188 \frac{e^{-\theta s}}{4.32s+1} \end{bmatrix}$$

For the diagonal pairings this gives the PI settings

$$K_{c1} = -12.1/(\tau_{c1} + \theta), \tau_{I1} = 4(\tau_{c1} + \theta); K_{c2} = -47.0/(\tau_{c2} + \theta), \tau_{I2} = 4.32$$

and for the off-diagonal pairings (the index refers to the output)

$$K_{c1} = 52.3/(\tau_{c1} + \theta + 2.16), \tau_{I1} = 4(\tau_{c1} + \theta + 2.16); K_{c2} = -14.3/(\tau_{c2} + \theta), \tau_{I2} = 4.32$$

For improved robustness, the level controller (y_1) is tuned about 3 times slower than the pressure controller (y_2), i.e. use $\tau_{c1} = 3\theta$ and $\tau_{c2} = \theta$. This gives a crossover frequency of about $0.5/\theta$ in the fastest loop. With a delay of about 5 s or larger you should find, as expected from the RGA at crossover frequencies (pairing rule 1), that the off-diagonal pairing is best. However, if the delay is decreased from 5 s to 1 s, then the diagonal pairing is best, as expected since the RGA for the diagonal pairing approaches 1 at frequencies above 1 rad/s.

Figures 3.7a and b present the simulations for these pairings.

Exercise 3.10 Design a SVD-controller $K = W_1 K_s W_2$ for the distillation process in (3.93), i.e. select $W_1 = V$ and $W_2 = U^T$ where U and V are given in (3.46). Select K_s in the form

$$K_s = \begin{bmatrix} c_1 \frac{75s+1}{s} & 0 \\ 0 & c_2 \frac{75s+1}{s} \end{bmatrix}$$

and try the following values:

1. $c_1 = c_2 = 0.005$;
2. $c_1 = 0.005, c_2 = 0.05$;
3. $c_1 = 0.7/197 = 0.0036, c_2 = 0.7/1.39 = 0.504$.

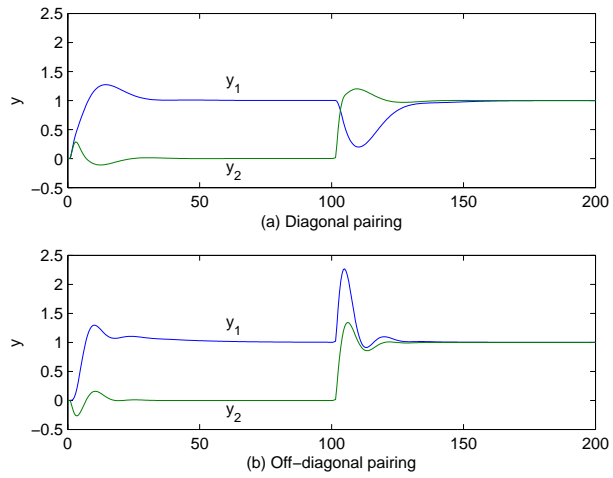

Fig. 3.7a. Simulation for $\theta = 1$ (Exercise 3.7).

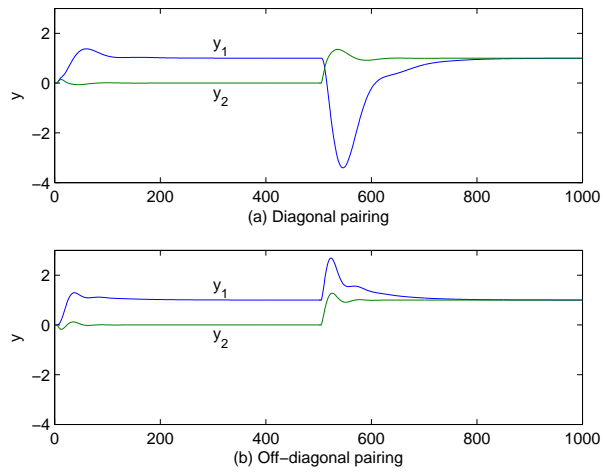
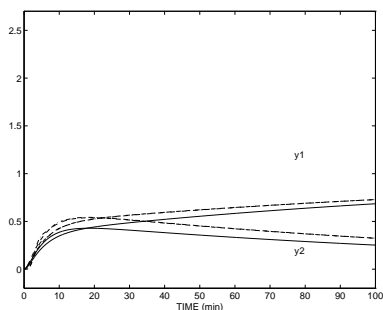

Fig. 3.7b. Simulation for $\theta = 5$ (Exercise 3.7).

Simulate the closed-loop reference response with and without uncertainty. Designs (a) and (b) should be robust. Which has the best performance? Design (c) should give the response in Figure 3.14. In the simulations, include high-order plant dynamics by replacing $G(s)$ by $\frac{1}{(0.02s+1)^5}G(s)$. What is the condition number of the controller in the three cases? Discuss the results. (See also the conclusion on page 251).

Solution. The simulation results of designs (a) and (b) are shown in the following figures.



(a) Design (a)

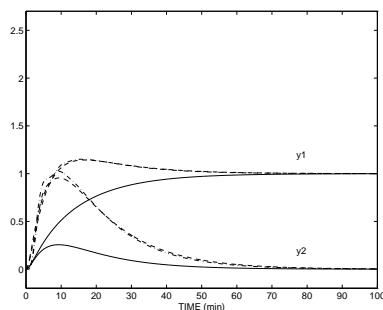

(b) Design (b)

Design (b) is the best if we want a fast settling time. By increasing c_2 we increase the loop gain in the weak direction.

The condition number of the controller:

Design (a): $\gamma(K) = 1$ and $\gamma_I^*(K) = 1$;

Design (b): $\gamma(K) = 10$ and $\gamma_I^*(K) = 1.0045$;

Design (c): $\gamma(K) = 197/1.39 = 128.777$ and $\gamma_I^*(K) = 1.0049$.

From this, design (a) is always robust with respect to uncertainty, whereas designs (b) and (c) are potentially sensitive to uncertainties.

Exercise 3.12 Consider again the distillation process $G(s)$ in (3.93). The response using the inverse-based controller K_{inv} in (3.95) was found to be sensitive to input gain errors. We want to see if the controller can be modified to yield a more robust system by using the Glover-McFarlane \mathcal{H}_∞ loop-shaping procedure. To this effect, let the shaped plant be $G_s = GK_{\text{inv}}$, i.e. $W_1 = K_{\text{inv}}$, and design an \mathcal{H}_∞ controller K_s for the shaped plant (see page 370 and Chapter 9), such that the overall controller becomes $K = K_{\text{inv}}K_s$. (You will find that $\gamma_{\text{min}} = 1.414$ which indicates good robustness with respect to coprime factor uncertainty, but the loop shape is almost unchanged and the system remains sensitive to input uncertainty.)

Solution. The following MATLAB script could be used to do this exercise. (To use these commands it is necessary to have the old μ -toolbox)

```
G0 = [87.8 -86.4; 108.2 -109.6];
dyn = nd2sys(1,[75 1]); Dyn = daug(dyn,dyn);
G = mmult(Dyn,G0);

% Inverse-based controller
```

```

dynk = nd2sys([75 1],[1 1.e-6],0.7);
Dynk = daug(dynk,dynk);
Kinv = mmult(Dynk,minv(G0));

% Try to robustify with respect to coprime uncertainty
Gs = mmult(G,Kinv);
[a,b,c,d]=unpck(Gs);
gamrel=1.1;
% gammin=1.4142:
[Ac,Bc,Cc,Dc,gammin]=coprim(a,b,c,d,gamrel);
% Change from positive to negative feedback:
Ks=pck(Ac,-Bc,Cc,-Dc);
K = mmult(Kinv,Ks);

% TIME simulation
% Nominal
GK = mmult(G,K); I2=eye(2); S = minv(madd(I2,GK));
T = msub(I2,S);
kr=nd2sys(1,[5 1]); Kr=daug(kr,kr); Tr = mmult(T,Kr);
y = trsp(Tr,[1;0],100,.1);
u = trsp(mmult(K,S,Kr),[1;0],100,.1);
% With 20% uncertainty
Unc = [1.2 0; 0 0.8]; GKu = mmult(G,Unc,K);
Su = minv(madd(I2,GKu)); Tu = msub(I2,Su);
Tru = mmult(Tu,Kr);
yu = trsp(Tru,[1;0],100,.1);
uu = trsp(mmult(K,Su,Kr),[1;0],100,.1);
subplot(211);vplot(y,yu,'--');title('OUTPUTS');
subplot(212);vplot(u,uu,'--');title('INPUTS');
xlabel('TIME (min)');

```

Exercise 3.14 Cascade implementation. Consider further Example 3.21. The local feedback based on y_2 is often implemented in a cascade manner; see also Figure 10.11. In this case the output from K_1 enters into K_2 and it may be viewed as a reference signal for y_2 . Derive the generalized controller K and the generalized plant P in this case.

Solution. The cascade structure is shown as follows.

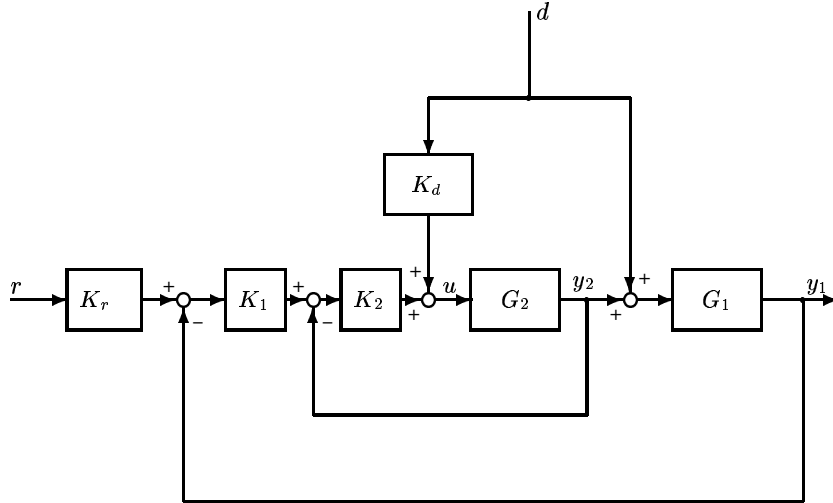

Since $u = K_2 K_1 K_r r - K_2 K_1 y_1 - K_2 y_2 + K_d d$, we get $K = [K_2 K_1 K_r \quad -K_2 K_1 \quad -K_2 \quad K_d]$. Also, we can get

$$\begin{bmatrix} y_1 - r \\ r \\ y_1 \\ y_2 \\ d \end{bmatrix} = \begin{bmatrix} G_1 & -I & G_1 G_2 \\ 0 & I & 0 \\ G_1 & 0 & G_1 G_2 \\ 0 & 0 & G_2 \\ I & 0 & 0 \end{bmatrix} \begin{bmatrix} d \\ r \\ u \end{bmatrix}.$$

Thus,

$$P = \begin{bmatrix} G_1 & -I & G_1 G_2 \\ 0 & I & 0 \\ G_1 & 0 & G_1 G_2 \\ 0 & 0 & G_2 \\ I & 0 & 0 \end{bmatrix}.$$

Exercise 3.16 Mixed sensitivity. Use the above procedure (page 111) to derive the generalized plant P for the stacked N in (3.105).

Solution. In (3.105),

$$N = \begin{bmatrix} W_u K S \\ W_T T \\ W_P S \end{bmatrix}.$$

1. Let $K = 0$ in N , we get,

$$P_{11} = N(K = 0) = \begin{bmatrix} 0 \\ 0 \\ W_P I \end{bmatrix}.$$

2. From

$$N - P_{11}$$

, we get,

$$Q = N - P_{11} = \begin{bmatrix} W_u K S \\ W_T T \\ W_P (S - I) \end{bmatrix} = \begin{bmatrix} W_u K (I + GK)^{-1} \\ W_T GK (I + GK)^{-1} \\ -W_P GK (I + GK)^{-1} \end{bmatrix}.$$

The common factor is $R = K(I + GK)^{-1}$. Thus, $G_{22} = -G$.

3. Since $Q = P_{12} R P_{21}$, we have,

$$P_{12} = \begin{bmatrix} W_u \\ W_T G \\ -W_P G \end{bmatrix},$$

and $P_{21} = I$.

As conclusion, we get,

$$P = \begin{bmatrix} 0 & W_u \\ 0 & W_T G \\ W_P I & -W_P G \\ I & -G \end{bmatrix}$$

Exercise 3.18 Consider the performance specification $\|w_P S\|_\infty < 1$. Suggest a rational transfer function weight $w_P(s)$ and sketch it as a function of frequency for the following two cases:

1. We desire no steady-state offset, a bandwidth better than 1 rad/s and a resonance peak (worst amplification caused by feedback) lower than 1.5.
2. We desire less than 1% steady-state offset, less than 10% error up to frequency 3 rad/s, a bandwidth better than 10 rad/s, and a resonance peak lower than 2. Hint: See (2.105) and (2.106).

Solution. $w_{P1} = \frac{s+1.5}{1.5s}$, and $w_{P2} = \frac{1}{2} \cdot \frac{(s+14.1)^2}{(s+1)^2}$. Comment: In the latter case we require that the magnitude should increase by a factor 10 when the frequency increases by approximately a factor $10^{1/2}$ (from 3 rad/s to 10 rad/s).

Exercise 3.20 What is the relationship between the RGA-matrix and uncertainty in the individual elements? Illustrate this for perturbations in the 1, 1-element of the matrix

$$A = \begin{bmatrix} 10 & 9 \\ 9 & 8 \end{bmatrix} \quad (3.114)$$

Solution. The inverse of the RGA-element directly gives the relative change in the element that gives singularity.

$$\text{RGA}(A) = \begin{bmatrix} -80 & 81 \\ 81 & -80 \end{bmatrix}$$

RGA-matrix has 1,1-element of -80, so G becomes singular if 1,1-element is perturbed from 10 to $10(1+1/80)=10.125$.

Exercise 3.22 Compute $\|A\|_{i1}$, $\bar{\sigma}(A) = \|A\|_{i2}$, $\|A\|_{i\infty}$, $\|A\|_F$, $\|A\|_{\max}$ and $\|A\|_{\text{sum}}$ for the following matrices and tabulate your results:

$$A_1 = I; \quad A_2 = \begin{bmatrix} 1 & 0 \\ 0 & 0 \end{bmatrix}; \quad A_3 = \begin{bmatrix} 1 & 1 \\ 1 & 1 \end{bmatrix}; \quad A_4 = \begin{bmatrix} 1 & 1 \\ 0 & 0 \end{bmatrix}, \quad A_5 = \begin{bmatrix} 1 & 0 \\ 1 & 0 \end{bmatrix}$$

Show using the above matrices that the following bounds are tight (i.e. we may have equality) for 2×2 matrices ($m = 2$):

$$\begin{aligned} \bar{\sigma}(A) &\leq \|A\|_F \leq \sqrt{m} \bar{\sigma}(A) \\ \|A\|_{\max} &\leq \bar{\sigma}(A) \leq m \|A\|_{\max} \\ \|A\|_{i1}/\sqrt{m} &\leq \bar{\sigma}(A) \leq \sqrt{m} \|A\|_{i1} \\ \|A\|_{i\infty}/\sqrt{m} &\leq \bar{\sigma}(A) \leq \sqrt{m} \|A\|_{i\infty} \\ \|A\|_F &\leq \|A\|_{\text{sum}} \end{aligned}$$

Solution. The result table is as follows:

	A	$\ A\ _{i1}$	$\bar{\sigma}(A) = \ A\ _{i2}$	$\ A\ _{i\infty}$	$\ A\ _F$	$\ A\ _{\max}$	$\ A\ _{\text{sum}}$
1.	$\begin{bmatrix} 1 & 0 \\ 0 & 1 \end{bmatrix}$	1	1	1	1.4142	1	2
2.	$\begin{bmatrix} 1 & 0 \\ 0 & 0 \end{bmatrix}$	1	1	1	1	1	1
3.	$\begin{bmatrix} 1 & 1 \\ 1 & 1 \end{bmatrix}$	2	2	2	2	1	4
4.	$\begin{bmatrix} 1 & 1 \\ 0 & 0 \end{bmatrix}$	1	1.4142	2	1.4142	1	2
5.	$\begin{bmatrix} 1 & 0 \\ 1 & 0 \end{bmatrix}$	2	1.4142	1	1.4142	1	2

From the table, the above bounds can be checked:

$$\begin{aligned} \bar{\sigma}(A_2) &= \|A_2\|_F, \quad \|A_1\|_F = \sqrt{2} \bar{\sigma}(A_1) \\ \|A_1\|_{\max} &= \bar{\sigma}(A_1), \quad \bar{\sigma}(A_4) = \sqrt{2} \|A_4\|_{\max} \\ \|A_5\|_{i1}/\sqrt{2} &= \bar{\sigma}(A_5), \quad \bar{\sigma}(A_4) = \sqrt{2} \|A_4\|_{i1} \\ \|A_4\|_{i\infty}/\sqrt{2} &= \bar{\sigma}(A_4), \quad \bar{\sigma}(A_5) = \sqrt{2} \|A_5\|_{i\infty} \\ \|A_2\|_F &= \|A_2\|_{\text{sum}} \end{aligned}$$

Exercise 3.24 Do the extreme singular values bound the magnitudes of the elements of a matrix? That is, is $\bar{\sigma}(A)$ greater than the largest element (in magnitude), and is $\underline{\sigma}(A)$ smaller than the smallest element? For a non-singular matrix, how is $\underline{\sigma}(A)$ related to the largest element in A^{-1} ?

Solution. The answer for the first question is “yes”, because $\|A\|_{\max} \leq \bar{\sigma}(A)$. But for the second question, the answer is “no”. As an example, consider $A = I$ for which $\underline{\sigma}(A) = 1$, but the smallest element is 0. For a non-singular matrix, $\underline{\sigma}(A)$ is smaller than inverse of the largest element in A^{-1} , because $\underline{\sigma}(A) = 1/\bar{\sigma}(A^{-1}) \leq 1/\|A^{-1}\|_{\max}$.

Exercise 3.26 Find two matrices A and B such that $\rho(A+B) > \rho(A) + \rho(B)$ which proves that the spectral radius does not satisfy the triangle inequality and is thus not a norm.

Solution. Let $A = \begin{bmatrix} 1 & 1 \\ 0 & 1 \end{bmatrix}$, and $B = \begin{bmatrix} 1 & 0 \\ 1 & 1 \end{bmatrix}$. $\rho(A) = \rho(B) = 1$, but $\rho(A+B) = 3 > \rho(A) + \rho(B) = 2$.

Exercise 3.28 Write K as an LFT of $T = GK(I + GK)^{-1}$, i.e. find J such that $K = F_l(J, T)$.

Solution. $T = GK(I + GK)^{-1}$ gives T as an LFT of K , but we want the inverse. We get $K = G^{-1}T(I - T)^{-1}$, so

$$J = \begin{bmatrix} 0 & G^{-1} \\ I & I \end{bmatrix}.$$

Exercise 3.30 Show that the set of all stabilizing controllers in (4.94) can be written as $K = F_l(J, Q)$ and find J .

Solution. In (4.94), $K = (V_r - QN_l)^{-1}(U_r + QM_l)$.

$$\begin{aligned} K &= (V_r - QN_l)^{-1}(U_r + QM_l) \\ &= V_r^{-1}U_r + (V_r - QN_l)^{-1}Q(M_l + N_lV_r^{-1}U_r) \\ &= V_r^{-1}U_r + V_r^{-1}(I - QN_lV_r^{-1})^{-1}Q(M_l + N_lV_r^{-1}U_r) \\ &= V_r^{-1}U_r + V_r^{-1}Q(I - N_lV_r^{-1}Q)^{-1}(M_l + N_lV_r^{-1}U_r) \end{aligned}$$

We get

$$J = \begin{bmatrix} V_r^{-1}U_r & V_r^{-1} \\ M_l + N_lV_r^{-1}U_r & N_lV_r^{-1} \end{bmatrix} \quad (3.115)$$

4

ELEMENTS OF LINEAR SYSTEM THEORY

Exercise 4.1 We want to find the normalized coprime factorization for the scalar system in (4.22). Let N and M be as given in (4.23), and substitute them into (4.24). Show that after some algebra and comparing of terms one obtains: $k = \pm 0.71$, $k_1 = 5.67$ and $k_2 = 8.6$.

Solution. Since $M^*(s) = M(-s)$, (4.24) can be written as $M(-s)M(s) + N(-s)N(s) = 1$. Thus:

$$\frac{k^2(2s^4 - 30s^2 + 148)}{s^4 - (k_1^2 - 2k_2)s^2 + k_2^2} = 1.$$

By comparing the terms of the denominator and numerator, it can be obtained that:

$$\begin{aligned} 2k^2 = 1 &\implies k = \pm 0.71, \\ 148k^2 = k_2^2 &\implies k_2 = 8.60, \\ 30k^2 = k_1^2 - 2k_2 &\implies k_1 = 5.67. \end{aligned}$$

Exercise 4.3 (a) Consider a SISO system $G(s) = C(sI - A)^{-1}B + D$ with just one state, i.e. A is a scalar. Find the zeros. Does $G(s)$ have any zeros for $D = 0$? (b) Do GK and KG have the same poles and zeros for a SISO system? Ditto, for a MIMO system?

Solution. (a) Zero at $z = A - (CB)/D$. When $D \rightarrow 0$ the zero moves to infinity, i.e. no zero.

(b) Yes, for SISO systems, $GK = KG$ have the same poles and zeros.

For MIMO systems, the poles are the same, but the zeros may be different, at least for cases where K and G are non-square. For cases where K and G are both square, we have that $\det(KG) = \det(GK) = \det(G) \cdot \det(K)$ and it follows that the zeros are generally the same (provided care is taken for pole-zero cancellations; see "important remark" no. 4).

For the non-square case, consider the following example, based on comments by Dr. Matthias Heller.

$$\begin{aligned} G &= [1/(s+2); 1/(s+1)] \\ K &= [1 \quad (s+3)/(s+4)] \end{aligned}$$

The resulting 2x2 transfer function GK has no (MIMO) zeros, but the 1x1 transfer function KG is

$$\frac{2s^2 + 10s + 10}{s^3 + 7s^2 + 14s + 8}$$

which has two zeros at -3.62 and -1.38, respectively. The poles for both GK and KG are the same; the two poles of G plus the pole of K .

Exercise 4.5 (a) Given $y(s) = G(s)u(s)$, with $G(s) = \frac{1-s}{1+s}$, determine a state-space realization of $G(s)$ and then find the zeros of $G(s)$ using the generalized eigenvalue problem. (b) What is the transfer function from $u(s)$ to $x(s)$, the single state of $G(s)$, and what are the zeros of this transfer function?

Solution. (a) A state-space realization of $G(s)$ is

$$\begin{aligned} \dot{x} &= -x + 2u \\ y &= x - u \end{aligned}$$

and

$$P(s) = \begin{bmatrix} s+1 & -2 \\ 1 & -1 \end{bmatrix}$$

Thus, zero at $s = 1$.

(b) From $u(s)$ to $x(s)$, the polynomial system matrix is:

$$P(s) = \begin{bmatrix} s+1 & -2 \\ 1 & 0 \end{bmatrix}$$

and the corresponding transfer function is $G(s) = \frac{s}{1+s}$, there are no zeros in this transfer function.

Exercise 4.7 For what values of c_1 does the following plant have RHP-zeros?

$$A = \begin{bmatrix} 10 & 0 \\ 0 & -1 \end{bmatrix}, \quad B = I, \quad C = \begin{bmatrix} 10 & c_1 \\ 10 & 0 \end{bmatrix}, \quad D = \begin{bmatrix} 0 & 0 \\ 0 & 1 \end{bmatrix} \quad (4.1)$$

Solution.

$$P(s) = \begin{bmatrix} s-10 & 0 & -1 & 0 \\ 0 & s+1 & 0 & -1 \\ 10 & c_1 & 0 & 0 \\ 10 & 0 & 0 & 1 \end{bmatrix}$$

If $s = c_1 - 1$, the sum of the 2nd and 4th rows of $P(s)$ is equal to the 3rd row. Thus $z = c_1 - 1$. So the plant has RHP-zero if $c_1 > 1$.

Exercise 4.9 Use (A.7) to show that the signal relationships (4.83) and (4.84) may also be written as

$$\begin{bmatrix} u \\ y \end{bmatrix} = M(s) \begin{bmatrix} d_u \\ d_y \end{bmatrix}; \quad M(s) = \begin{bmatrix} I & K \\ -G & I \end{bmatrix}^{-1} \quad (4.85)$$

From this we get that the system in Figure 4.3 is internally stable if and only if $M(s)$ is stable.

Solution. Signal relationships (4.83) and (4.84) are:

$$u = (I + KG)^{-1}d_u - K(I + GK)^{-1}d_y \quad (4.83)$$

$$y = G(I + KG)^{-1}d_u + (I + GK)^{-1}d_y \quad (4.84)$$

Which can be written as:

$$\begin{bmatrix} u \\ y \end{bmatrix} = \begin{bmatrix} (I + KG)^{-1} & -K(I + GK)^{-1} \\ G(I + KG)^{-1} & (I + GK)^{-1} \end{bmatrix} \begin{bmatrix} d_u \\ d_y \end{bmatrix}$$

Noting that $G(I + KG)^{-1} = (I + GK)^{-1}G$ and $(I + KG)^{-1} = I - K(I + GK)^{-1}G$:

$$\begin{bmatrix} (I + KG)^{-1} & -K(I + GK)^{-1} \\ G(I + KG)^{-1} & (I + GK)^{-1} \end{bmatrix} \begin{bmatrix} d_u \\ d_y \end{bmatrix} = \begin{bmatrix} I - K(I + GK)^{-1}G & -K(I + GK)^{-1} \\ (I + GK)^{-1}G & (I + GK)^{-1} \end{bmatrix}$$

Since $X = I + GK$ and using (A.7):

$$\begin{bmatrix} I + KX^{-1}(-G) & -KX^{-1} \\ -X^{-1}(-G) & X^{-1} \end{bmatrix} = \begin{bmatrix} I & K \\ -G & I \end{bmatrix}^{-1} = M$$

Exercise 4.11 Given the complementary sensitivity functions

$$T_1(s) = \frac{2s + 1}{s^2 + 0.8s + 1} \quad T_2(s) = \frac{-2s + 1}{s^2 + 0.8s + 1}$$

what can you say about possible RHP-poles or RHP-zeros in the corresponding loop transfer functions, $L_1(s)$ and $L_2(s)$?

Solution. Assume internal stability:

1) Compute $S_1 = 1 - T_1 = \frac{s(s-1.2)}{s^2+0.8s+1}$. Since S_1 has a RHP-zero, we conclude that L_1 is unstable with a RHP-pole at $s=1.2$ (and also with a pole at $s = 0$).

2) T_2 has a RHP-zero, so L_2 has a RHP-zero at $s = 0.5$.

Exercise 4.13 Show that the IMC-structure in Figure 4.5 is internally unstable if either Q or G is unstable.

Solution. In Figure 4.5, it can be derived that $u = K(r - y)$ where $K = (I - QG)^{-1}Q$, i.e. equation (4.89). Thus, $Q = K(I + GK)^{-1}$. According to Lemma 4.6 if either Q or G is unstable then the IMC system is internally unstable.

Exercise 4.15 Given a stable controller K . What set of plants can be stabilized by this controller? (Hint: interchange the roles of plant and controller.)

Solution. The set of the plants can be parameterized as:

$$G = (I - QK)^{-1}Q = Q(I - KQ)^{-1},$$

where ‘‘parameter’’ Q is any stable transfer function matrix.

5

LIMITATIONS ON PERFORMANCE IN SISO SYSTEMS

Exercise 5.1 Kalman inequality *The Kalman inequality for optimal state feedback, which also applies to unstable plants, says that $|S| \leq 1 \forall \omega$, see Example 9.2. Explain why this does not conflict with the above sensitivity integrals.*

Solution. 1. Optimal control with state feedback yields a loop transfer function with a pole-zero excess of 1 so (5.5) does not apply.

2. There are no RHP-zeros when all states are measured so (5.9) does not apply.

Exercise 5.3 *Consider again the plant (5.24) from Example 5.2. Compute the bounds on $\|S\|_\infty$, $\|T\|_\infty$, $\|KS\|_\infty$ and $\|SG\|_\infty$ using Table 5.1. Do you expect any difficulties in controlling this plant?*

Solution. The plant

$$G(s) = 10 \cdot \frac{s - 2}{s^2 - 2s + 5}$$

has a RHP-zero at $z = 2$ and RHP-poles as $p = 1 \pm j2$.

From (5.15):

$$\|S\|_\infty \geq \underbrace{\prod_{i=1}^{N_p} \frac{|z + p_i|}{|z - p_i|}}_{M_{z p_i}} = \frac{(2 + 1 - j2)(2 + 1 + j2)}{(2 - 1 + j2)(2 - 1 - j2)} = 2.6 \quad (5.15)$$

From (5.22):

$$\|T\|_\infty \geq M_{T, \min} = \underbrace{\prod_{i=1}^{N_p} \frac{|z + p_i|}{|z - p_i|}}_{M_{z p_i}} = \frac{(2 + 1 - j2)(2 + 1 + j2)}{(2 - 1 + j2)(2 - 1 - j2)} = 2.6 \quad (5.22)$$

From (5.30):

$$\|KS\|_\infty \geq 1/\underline{\sigma}_H(\mathcal{U}(G)^*) = 0.5908 \quad (5.30)$$

From (5.28):

$$\|SG\|_\infty \geq |G_{ms}(z)| \underbrace{\prod_{i=1}^{N_p} \frac{|z + p_i|}{|z - p_i|}}_{M_{z p_i}} = |G_m(z)| = 10 \left(\frac{s+2}{s^2 - 2s + 5} \right)_{s=2} = 3.076 \quad (5.28)$$

As the minimum bounds $M_S = 2.6$ and $M_{T,\min} = 2.6$ are larger than the typical maximum allowed value of about 2, it is expected that this plant will be difficult to stabilize and control from a practical point of view.

Also, $\|SG\|_\infty \geq 3.08$ which may not be acceptable if it is required to keep $\|y\|_2 < 1$ for all input disturbances less than 1 (this would require $\|SG\|_\infty < 1$).

Exercise 5.6 Consider the weight $w_P(s) = \frac{1}{M} + \left(\frac{\omega_B^*}{s}\right)^n$ which requires $|S|$ to have a slope of n at low frequencies and requires its low-frequency asymptote to cross 1 at a frequency ω_B^* . Note that $n = 1$ yields the weight (5.49) with $A = 0$. Derive an upper bound on ω_B^* when the plant has a RHP-zero at z . Show that the bound becomes $\omega_B^* \leq |z|$ as $n \rightarrow \infty$.

Solution. When $z > 0$ is real, from $|w_P(z)| < 1$ we have:

$$\omega_B^* < z(1 - 1/M)^{1/n}.$$

When z is imaginary, we get:

$$\omega_B^* < \begin{cases} |z| \left(1 - \frac{1}{M^2}\right)^{1/n} & n = 2k - 1, k = 1, 2, \dots \\ |z| \left(1 - \frac{(-1)^k}{M}\right)^{1/n} & n = 2k, k = 1, 2, \dots \end{cases}$$

In all these cases, $\omega_B^* < |z|$ as $n \rightarrow \infty$.

Exercise 5.9 Consider the case of a plant with a RHP-zero z where we want to limit the sensitivity function over some frequency range. To this effect let

$$w_P(s) = \frac{\left(\frac{1000s}{\omega_B^*} + \frac{1}{M}\right)\left(\frac{s/M}{\omega_B^*} + 1\right)}{\left(\frac{10s}{\omega_B^*} + 1\right)\left(\frac{100s}{\omega_B^*} + 1\right)} \quad (5.59)$$

This weight is equal to $1/M$ at low and high frequencies, has a maximum value of about $10/M$ at intermediate frequencies, and the asymptote crosses 1 at frequencies $\omega_B^*/1000$ and ω_B^* . Thus we require “tight” control, $|S| < 1$, in the frequency range between $\omega_{BL}^* = \omega_B^*/1000$ and $\omega_{BH}^* = \omega_B^*$.

a) Make a sketch of $1/|w_P|$ (which provides an upper bound on $|S|$).

b) Show that the RHP-zero z cannot be in the frequency range where we require tight control, and that we can achieve tight control either at frequencies below about $z/2$ (the usual case) or above about $2z$. To see this select $M = 2$ and evaluate $w_P(z)$ for various values of $\omega_B^* = kz$, e.g. $k = 0.1, 0.5, 1, 10, 100, 1000, 2000, 10000$. (You will find that $w_P(z) = 0.95$ (≈ 1) for $k = 0.5$ (corresponding to the requirement $\omega_{BH}^* < z/2$) and for $k = 2000$ (corresponding to the requirement $\omega_{BL}^* > 2z$))

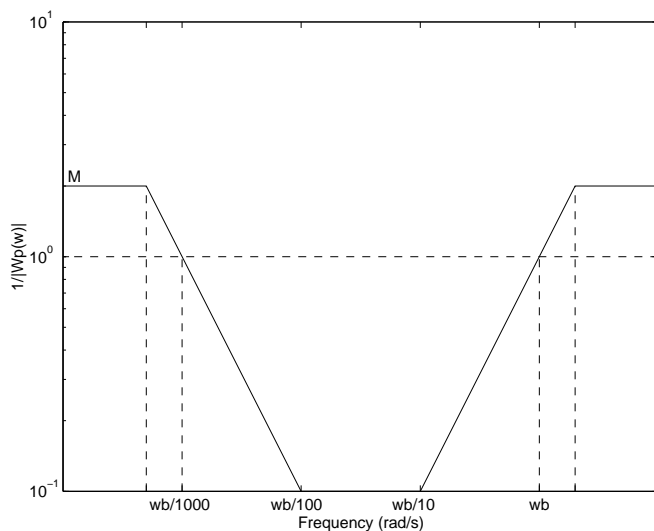

Fig. 5.9. Figure for exercise 5.9

Solution. a) The asymptotic magnitude Bode-plot is shown as follows (see Figure 5.9):

b) In the above plot between $\omega_B^*/1000$ and ω_B^* $1/w_P(\omega) \leq 1$. Hence to satisfy the condition $|w_P(z)| < 1$, z cannot be in the frequency range from $\omega_B^*/1000$ to ω_B^* where we require tight control.

The values of $w_P(z)$ via $k = \omega_B^*/z$ for $M = 2$ are shown in the following table:

k	$w_P(z)$
0.1	0.59350
0.5	0.94788
1.0	1.3508
10.0	4.7966
100.0	4.7966
1000.0	1.3508
2000.0	0.94788
10000.0	0.59350

Exercise 5.10 For purely imaginary poles located at $p = \pm j|p|$ a similar analysis of the weight (5.68) with $M_T = 2$ shows that we must at least require $\omega_{BT}^* > 1.15|p|$. Derive this bound.

Solution. $|w_T(p)| = \sqrt{\frac{|p|^2}{\omega_{BT}^{*2}} + \frac{1}{M_T^2}} < 1 \Rightarrow \omega_{BT}^* > \frac{|p|M_T}{\sqrt{M_T^2 - 1}} = 1.1547|p|$.

Exercise 5.11 For a system with a single real RHP-zero z and N_p RHP-poles p_i and tight

control at low frequencies ($A = 0$ in (5.50) derive the following generalization of (5.52):

$$\omega_B^* < z \left(\prod_{i=1}^{N_p} \frac{|z - p_i|}{|z + p_i|} - \frac{1}{M} \right) \quad (5.74)$$

(Hint: Use (5.13).) Note that for a plant with a single RHP-pole and RHP-zero the bound (5.74) with $M = 2$ is feasible (upper bound on ω_B^* is positive) for $p < 0.33z$. This confirms the approximate bound $p < 0.25z$ derived for stability with acceptable low-frequency performance and robustness on page 196.

Solution. Joining (5.13) and (5.47), we have that:

$$|w_P(z)| \cdot \underbrace{\prod_{i=1}^{N_p} \frac{|z + p_i|}{|z - p_i|}}_{M_{z p_i}} \leq \|w_P S\|_\infty < 1$$

Considering the performance weight (5.50):

$$|w_P(z)| = \left| \frac{z/M + w_B^*}{z + w_B^* A} \right| \quad (5.50)$$

So, we have that:

$$\begin{aligned} \left| \frac{z/M + w_B^*}{z + w_B^* A} \right| \cdot \prod_{i=1}^{N_p} \frac{|z + p_i|}{|z - p_i|} &< 1 \\ \left| \frac{z/M + w_B^*}{z + w_B^* A} \right| &< \prod_{i=1}^{N_p} \frac{|z - p_i|}{|z + p_i|} \end{aligned}$$

When z is real, all variables are real and positive, so (with $A = 0$)

$$\omega_B^* < z \left(\prod_{i=1}^{N_p} \frac{|z - p_i|}{|z + p_i|} - \frac{1}{M} \right)$$

Exercise 5.12 Perform closed-loop simulations with the SIMC PI controller and the proposed PID controller for the room heating process. Also compute the robustness parameters (GM , PM , M_S and M_T) for the two designs.

Solution. The model for the heating room is:

$$G(s) = \frac{20e^{-100s}}{1000s + 1}; G_d(s) = \frac{10}{1000s + 1}$$

The SIMC and PID tunings used were:

SIMC: $K_c = 0.25$ and $\tau_I = 800$ s

PID: $K_c = 0.4$, $\tau_I = 200$ s and $\tau_D = 60$ s

The closed-loop simulations with SIMC PI and PID controllers are presented in Figure 5.12.

The robustness parameters are:

For SIMC PI: $GM = 3.1060(9.8439dB)$, $PM = 58.3494$, $M_S = 1.6039$, and $M_T = 1.0443$;

For PID: $GM = 1.6281(4.2335dB)$, $PM = 38.6326$, $M_S = 2.6406$, and $M_T = 1.7102$.

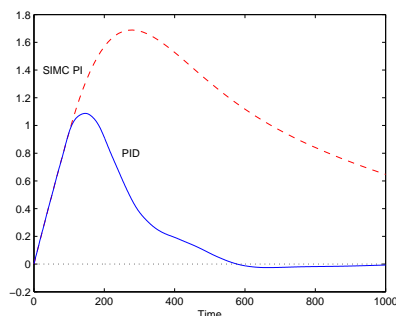

(c) Step disturbance in outdoor temperature

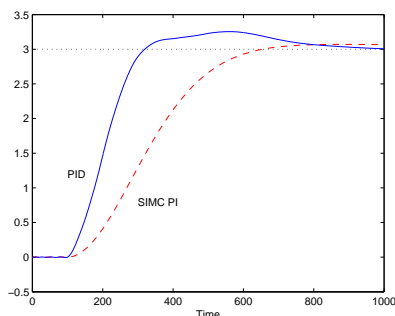

(d) Setpoint change $3/(150s + 1)$

Exercise 5.14 (a) The effect of a concentration disturbance must be reduced by a factor of 100 at the frequency 0.5 rad/min. The disturbances should be dampened by use of buffer tanks and the objective is to minimize the total volume. How many tanks in series should one have? What is the total residence time?

(b) The feed to a distillation column has large variations in concentration and the use of one buffer tank is suggested to dampen these. The effect of the feed concentration d on the product composition y is given by (scaled variables, time in minutes)

$$G_d(s) = e^{-s}/3s$$

That is, after a step in d the output y will, after an initial delay of 1 min, increase in a ramp-like fashion and reach its maximum allowed value (which is 1) after another 3 minutes. Feedback control should be used and there is an additional measurement delay of 5 minutes. What should be the residence time in the tank?

(c) Show that in terms of minimizing the total volume for buffer tanks in series, it is optimal to have buffer tanks of equal size.

(d) Is there any reason to have buffer tanks in parallel (they must not be of equal size because then one may simply combine them)?

(e) What about parallel pipes in series (pure delay). Is this a good idea?

Solution.

(a) From (5.116) we must require

$$|h_n(j\omega_0)| = \frac{1}{\left(\frac{\tau_n}{n}\omega_0\right)^2 + 1} = 0.01$$

This gives

$$\tau_n = \frac{n}{\omega_0} \sqrt{100^{2/n} - 1}$$

With $\omega_0 = 0.5$ rad/min we find

n	τ_n
1	200
2	39.80
3	27.20
4	24.00
5	23.04
6	22.90
7	23.12
10	24.59

and we find that to minimize τ_n we should have 6 tanks in series with a total residence time $\tau_n = 22.90$ min. (In practice, we would prefer fewer tanks because the number of tanks increases the cost, and probably use only 2 or at most 3 tanks).

(b) Assume the transfer function of the tank is

$$h(s) = \frac{1}{\tau_h s + 1}$$

The total delay in the feedback loop is $\theta = 1 + 5 = 6$ [min]. To make the system controllable, we need

$$|G_d(j/\theta) \cdot h(j/\theta)| \leq 1.$$

This leads to $\tau_h \geq 10.39$ [min].

(c) Consider the case with two buffer tanks with total residence time τ_h . Let the residence time in one of the tanks be x . Then

$$h_2(s) = \frac{1}{(1 + xs)(1 + (\tau_h - x)s)} = \frac{1}{1 + \tau_h s + (\tau_h - x)x s^2}$$

and the high-frequency asymptote becomes $|h_2(j\omega)| \approx 1/[(\tau_h - x)x\omega^2]$ which is minimized by selecting $x = \tau_h/2$, that is, the tanks should be of equal size to get the best disturbance attenuation with a given total volume. For n tanks in series we get the same result by considering the high-frequency asymptote.

(d) It seems no any such reasons.

(e) It certainly may dampen disturbances, but probably tanks are better.

Exercise 5.16 *What information about a plant is important for controller design, and in particular, in which frequency range is it important to know the model well? To answer this problem you may think about the following sub-problems:*

(a) *Explain what information about the plant is used for Ziegler-Nichols tuning of a SISO PID-controller.*

(b) *Is the steady-state plant gain $G(0)$ important for controller design? (As an example consider the plant $G(s) = \frac{1}{s+a}$ with $|a| \leq 1$ and design a P-controller $K(s) = K_c$ such that $\omega_c = 100$. How does the controller design and the closed-loop response depend on the steady-state gain $G(0) = 1/a$?)*

Solution. (a) ω_u and $|G(\omega_u)|$, that is, only information at frequency ω_u is used.

(b) As just noted the steady-state information is not needed for Ziegler-Nichols tuning, and it is generally not important for feedback design. This is illustrated by the example where $K_c = \sqrt{\omega_c^2 + a^2} = \sqrt{10000 + a^2} \approx 100$ for any value of $a \leq 1$. Thus response hardly effected by a . Main effect is on steady-state offset which is $\frac{1}{1+K_c/a} \approx a/K_c$ and may vary between 0 (for $a = 0$) and 0.01 (for $a = 1$).

Exercise 5.18 A heat exchanger is used to exchange heat between two streams; a coolant with flowrate q (1 ± 1 kg/s) is used to cool a hot stream with inlet temperature T_0 ($100 \pm 10^\circ$ C) to the outlet temperature T (which should be $60 \pm 10^\circ$ C). The measurement delay for T is 3s. The main disturbance is on T_0 . The following model in terms of deviation variables is derived from heat balances

$$T(s) = \frac{8}{(60s+1)(12s+1)}q(s) + \frac{0.6(20s+1)}{(60s+1)(12s+1)}T_0(s) \quad (5.121)$$

where T and T_0 are in $^\circ$ C, q is in kg/s, and the unit for time is seconds. Derive the scaled model. Is the plant controllable with feedback control? (Solution: The delay poses no problem (performance), but the effect of the disturbance is a bit too large at high frequencies (input saturation), so the plant is not controllable).

Solution. Since $|G_d(j\omega)| < 1$, especially $|G_d(j\frac{1}{\theta})| < 1$, the delay poses no problem. But input constraint does! Let $y = T/10$, $u = q/1$ and $d = T_0/10$, then the scaled model is:

$$y(s) = \frac{0.8}{(60s+1)(12s+1)}u(s) + \frac{0.6(20s+1)}{(60s+1)(12s+1)}d(s)$$

So, $|G|/|G_d| = \frac{0.8}{0.6\sqrt{400\omega^2+1}} < 1$, when $\omega > \frac{\sqrt{(0.8/0.6)^2-1}}{20} = 0.0441$, i.e. at high frequencies the disturbance is too large which will cause input saturation. Thus the plant is not controllable.

6

LIMITATIONS ON PERFORMANCE IN MIMO SYSTEMS

Exercise 6.3 To illustrate further the above arguments, determine the sensitivity function S for the plant (6.31) and $K = \frac{k}{s}I$. Use the approximation $e^{-\theta s} \approx 1 - \theta s$ to show that at low frequencies the elements of $S(s)$ are of magnitude $1/(k\theta + 2)$. How large must k be to have acceptable performance (less than 10% offset at low frequencies)? What is the corresponding bandwidth? (Answer: Need $k > 8/\theta$. Bandwidth is equal to k .)

Solution. Using $S = (I + GK)^{-1}$ and $e^{-\theta s} \approx 1 - \theta s$, it can be obtained that

$$S = \frac{1}{s + k(2 + \theta k)} \begin{bmatrix} s + k & -k \\ -k(1 - \theta s) & s + k \end{bmatrix}$$

Thus at low frequencies ($s \approx 0$), the elements of S all have the magnitude of $1/(2 + \theta k)$. To maintain 10% offset at low frequencies, let $1/(2 + \theta k) < 1/10$. It leads to $k > 8/\theta$. The bandwidth is obtained by letting:

$$\left| \frac{-k(1 - j\theta\omega)}{j\omega + k(2 + \theta k)} \right| = 1.$$

This gives $k^2 + k^2\theta^2\omega^2 = \omega^2 + k^2(2 + \theta k)^2$. Since $k > 8/\theta$, $\theta k \gg 2$, i.e. $k^2\theta^2 \approx (2 + \theta k)^2$. Thus the equation for bandwidth can be simplified as $k^2 = \omega^2$, i.e. the bandwidth is equal to k .

Exercise 6.5 For a plant with a single real RHP-zero z with input direction u_z and a diagonal performance weight matrix W_P , show that the requirement $\|W_P S\|_\infty < 1$ implies

$$\sum_i |w_{P,i}(z)|^2 |u_{z,i}|^2 < 1$$

If $w_{P,i}$ is given by (5.50) and $w_{P,j} = 0$, $i \neq j$ (arbitrarily poor control of all outputs other than y_i), show that tight control of y_i at low frequencies imposes the following limitation on $\omega_{B,i}^*$:

$$\omega_{B,i}^* < z \left(\frac{1}{u_{z,i}} - \frac{1}{M} \right)$$

Solution.

Unfortunately, the result does not hold as originally stated: Instead of $\|W_P S\|_\infty < 1$ one could consider $\|W_P S_I\|_\infty < 1$ (which is OK mathematically but makes less sense from a physical point of view).

Alternatively (and better), the exercise should start with "For a system $L = GK$ with a single...". The solution then goes as follows:

If $L(s)$ has a RHP-zero at z with input direction u_z , then for internal stability of the feedback system the following interpolation constraint applies:

$$S(z)u_z = u_z$$

Then, if we multiply $W_P S$ by u_z , we have that

$$W_P S u_z = W_P u_z$$

As W_P is diagonal ($W_P = \text{diag}(w_{P,i})$), we have that

$$\|\text{diag}(w_{P,i})u_z\|_\infty < 1$$

Taking the square of both sides, we see that

$$\|(u_z^T \text{diag}(w_{P,i}))(\text{diag}(w_{P,i})u_z)\|_\infty \leq \|u_z^T \text{diag}(w_{P,i})\|_\infty \cdot \|\text{diag}(w_{P,i})u_z\|_\infty < 1$$

So

$$\left\| \sum_i |w_{P,i}(z)|^2 |u_{z,i}|^2 \right\|_\infty = \sum_i |w_{P,i}(z)|^2 |u_{z,i}|^2 < 1$$

Considering that $w_{P,i}$ is given by (5.50) and $w_{P,j} = 0, i \neq j$, from

$$\sum_i |w_{P,i}(z)|^2 |u_{z,i}|^2 < 1$$

we have that

$$\frac{\frac{z}{M} + w_B^*}{z + w_B^* A} u_{z,i} < 1$$

With $A = 0$ (no steady-state offset):

$$\frac{z}{M} + w_B^* < \frac{z}{u_{z,i}}$$

Then

$$w_B^* < z \left(\frac{1}{u_{z,i}} - \frac{1}{M} \right)$$

Exercise 6.6 Consider the plant

$$G(s) = \begin{bmatrix} \alpha & 1 \\ \frac{1}{s+1} & \alpha \end{bmatrix} \quad (6.39)$$

(a) Find the zero and its output direction.

(b) Which values of α yield a RHP-zero, and which of these values is best/worst in terms of achievable performance?

(c) Suppose $\alpha = 0.1$. Which output is the most difficult to control? Illustrate your conclusion using Theorem 6.4.

Solution. (a) $z = \frac{1}{\alpha^2} - 1$ because $\text{Rank}G(z) = 1$. The output zero direction is obtained from $y_z^H G(z) = 0$. This gives $y_z = [-\alpha \ 1]^T$.

(b) We have a RHP-zero for $|\alpha| < 1$. Best for $\alpha = 0$ with zero at infinity; if control at steady-state is required then worst for $\alpha = 1$ with zero at $s = 0$.

(c) Output 2 is most difficult since the zero is mainly in that direction; we get strong interaction with $\beta = 20$ in (6.38) if we want to control y_2 perfectly.

Exercise 6.8 Analyze input-output controllability for

$$G(s) = \frac{1}{s^2 + 100} \begin{bmatrix} \frac{1}{0.01s+1} & 1 \\ \frac{s+0.1}{s+1} & 1 \end{bmatrix}$$

Compute the zeros and poles, plot the RGA as a function of frequency, etc.

Solution. The system has 6 poles: $\pm j10$, $\pm j10$, 1 and 100; 2 zeros: -9.537 and 9.437 (RHP-zero). The diagonal elements of the RGA are: $\lambda_{11} = \lambda_{22} = (1 - \frac{g_{12}g_{21}}{g_{11}g_{22}})^{-1}$ and off-diagonal elements of the RGA are: $\lambda_{12} = \lambda_{21} = 1 - \lambda_{11}$. The amplitudes of these elements are shown as functions of frequency in Fig. 6.8(a). It is shown in the figure that all elements of the RGA

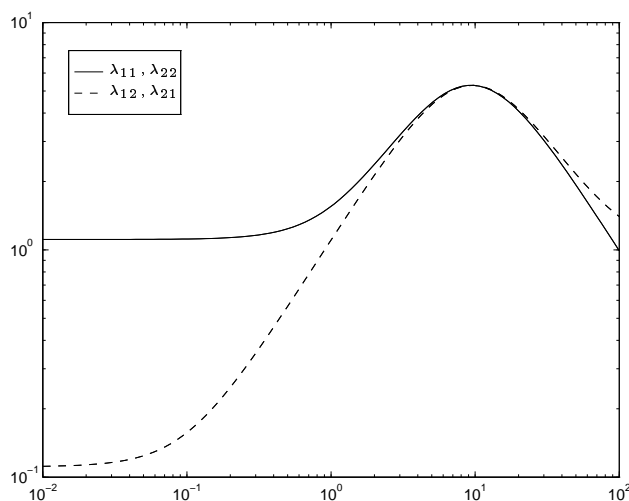

Fig. 6.8(a) The RGA of exercise 6.8

have a peak about 6 at $\omega = 10$. The singular values of the system are shown in Fig. 6.8(b). It is shown that the sv is less than 1 at all frequencies. Thus it is difficult to control this plant.

Exercise 6.10 Let

$$A = \begin{bmatrix} -10 & 0 \\ 0 & -1 \end{bmatrix}, B = I, C = \begin{bmatrix} 10 & 1.1 \\ 10 & 0 \end{bmatrix}, D = \begin{bmatrix} 0 & 0 \\ 0 & 1 \end{bmatrix}$$

(a) Perform a controllability analysis of $G(s)$.

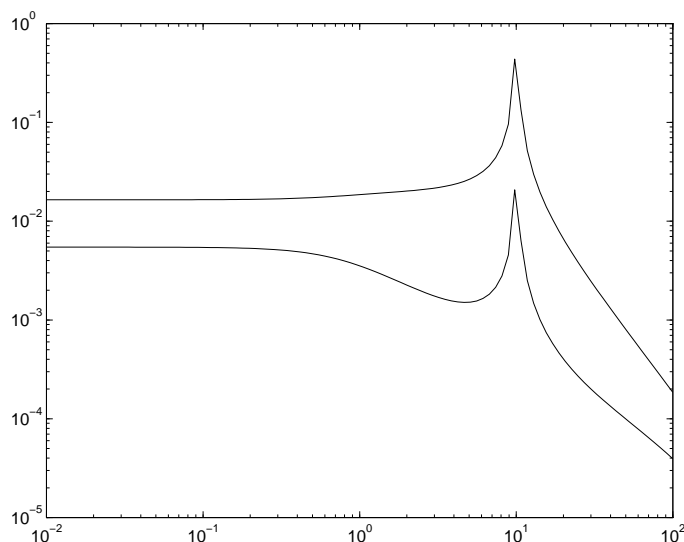

Fig. 6.8(b) The SV of exercise 6.8

(b) Let $\dot{x} = Ax + Bu + d$ and consider a unit disturbance $d = [z_1 \ z_2]^T$. Which direction (value of z_1/z_2) gives a disturbance that is most difficult to reject (consider both RHP-zeros and input saturation)?

(c) Discuss decentralized control of the plant. How would you pair the variables?

Solution. (a) The transfer function matrix is:

$$G(s) = \begin{bmatrix} \frac{10}{s+10} & \frac{1.1}{s+1} \\ \frac{10}{s+10} & 1 \end{bmatrix}.$$

The system has two stable poles: -10 and -1 and one RHP-zero: $z = 0.1$. The RGA matrix is:

$$\text{RGA} = \begin{bmatrix} \frac{10(s+1)}{10s-1} & \frac{-11}{10s-1} \\ \frac{-11}{10s-1} & \frac{10(s+1)}{10s-1} \end{bmatrix}.$$

Thus, the magnitudes of the RGA elements are large (about 10) at low frequencies and small at high frequency (approximating to a unit matrix). But the approximation is at $\omega \gg 1 \gg z$, i.e. "outside" the bandwidth which is limited by the RHP-zero, $z = 0.1$.

(b) At steady-state, $G(0) = \begin{bmatrix} 1 & 1.1 \\ 1 & 1 \end{bmatrix}$ and the most difficult output direction is $\underline{u}(0) = [-0.689 \ 0.725]^T$. Let $d = [1 \ k]^T$. Then, $g_d(0) = -BA^{-1}d = [1 + 1.1k \ 1]^T$. So, in the most difficult direction, $g_d(0)/\|g_d(0)\| = \underline{u}(0)$, i.e. $1 + 1.1k = -0.689/0.725$. This gives $k = -1.77$.

(c) At the steady state,

$$\text{RGA}(0) = \begin{bmatrix} -10 & 11 \\ 11 & -10 \end{bmatrix}.$$

Thus the best pairing for decentralized control is: (y_1, u_2) and (y_2, u_1) .

Exercise 6.12 Order the following three plants in terms of their expected ease of controllability

$$G_1(s) = \begin{bmatrix} 100 & 95 \\ 100 & 100 \end{bmatrix}, G_2(s) = \begin{bmatrix} 100e^{-s} & 95e^{-s} \\ 100 & 100 \end{bmatrix}, G_3(s) = \begin{bmatrix} 100 & 95e^{-s} \\ 100 & 100 \end{bmatrix}$$

Remember to also consider the sensitivity to input gain uncertainty.

Solution. G_1 and G_2 have the same RGA matrix which is constant with $\lambda_{11} = \lambda_{22} = 20$ and $\lambda_{12} = \lambda_{21} = 19$. These large RGA values indicate both G_1 and G_2 are difficult to be controlled. Additionally G_2 has a delay in output 1 thus is worse than G_1 . With the approximation of $e^{-s} \approx 1 - s$ the RGA of G_3 can be expressed as: $\lambda_{11} = \lambda_{22} = \frac{100}{5+95s}$ and $\lambda_{12} = \lambda_{21} = \frac{95(s-1)}{5+95s}$. When $\omega \approx 1$ the system is well-conditioned (the RGA $\approx I$). So G_3 is the best one, then G_1 and G_2 is the worst.

Exercise 6.14 Analyze input-output controllability for

$$G(s) = \begin{bmatrix} 100 & 102 \\ 100 & 100 \end{bmatrix}, \quad g_{d1}(s) = \begin{bmatrix} \frac{10}{s+1} \\ \frac{10}{s+1} \end{bmatrix}; \quad g_{d2} = \begin{bmatrix} \frac{1}{s+1} \\ \frac{-1}{s+1} \end{bmatrix}$$

Which disturbance is the worst?

Solution. This is a ill-conditioned plant. The RGA, $\lambda_{11} = -50$ at all frequencies. Disturbance d_1 is in the same direction of u_1 , thus is easy to be rejected. The disturbance condition numbers for the two disturbances are, $\gamma_{d1} = 1.4213$ and $\gamma_{d2} = 202.01$. Hence, d_2 is more difficult to be rejected than d_1 .

Exercise 6.16 Find the poles and zeros and analyze input-output controllability for

$$G(s) = \begin{bmatrix} c + (1/s) & 1/s \\ 1/s & c + (1/s) \end{bmatrix}$$

Here c is a constant, e.g. $c = 1$.

Remark. A similar model form is encountered for distillation columns controlled with the DB -configuration. In which case the physical reason for the model being singular at steady-state is that the sum of the two manipulated inputs is fixed at steady-state, $D + B = F$.

Solution. For the computations we select $c = 1$. The plant has two poles at $s = 0$ and one LHP-zero at $s = 0$, e.g. consider the realization

$$G(s) = \frac{1}{s^2} \begin{bmatrix} cs + 1 & 1 \\ 1 & cs + 1 \end{bmatrix}$$

Here $G(s)$ has a zero at $s = 0$ since the matrix $\begin{bmatrix} cs + 1 & 1 \\ 1 & cs + 1 \end{bmatrix}$ has a zero for $s = 0$. (alternatively, we may have a realization with only one pole at $s = 0$ e.g. $A = 0$ (scalar), $B = [1 \ 1]$, $C = \begin{bmatrix} 1 \\ 1 \end{bmatrix}$, $D = I$), but we then have no zero at $s = 0$). In any case, the plant is unstable and needs to be stabilized.

The plant is singular at steady-state (with infinite RGA and condition number). This may seem to indicate that control is very difficult, but this is not the case. The reason is that the singularity is caused by the largest singular value being infinite at steady-state, whereas the smallest singular value is $|c| = 1$ at $s = 0$ so it is non-zero (if the smallest singular value was zero at $s = 0$ then tight control at steady-state would be impossible).

In summary, acceptable control for this plant is possible provided the bandwidth is sufficiently high (higher than about frequency $|c|$).

7

UNCERTAINTY AND ROBUSTNESS FOR SISO SYSTEMS

Exercise 7.2 Suppose that the nominal model of a plant is

$$G(s) = \frac{1}{s+1}$$

and the uncertainty in the model is parameterized by multiplicative uncertainty with the weight

$$w_I(s) = \frac{0.125s + 0.25}{(0.125/4)s + 1}$$

Call the resulting set Π . Now find the extreme parameter values in each of the plants (a)-(g) below so that each plant belongs to the set Π . All parameters are assumed to be positive. One approach is to plot $l_I(\omega) = |G^{-1}G' - 1|$ in (7.25) for each G' (G_a, G_b , etc.) and adjust the parameter in question until l_I just touches $|w_I(j\omega)|$.

- (a) Neglected delay: Find the largest θ for $G_a = Ge^{-\theta s}$ (Answer: 0.13).
- (b) Neglected lag: Find the largest τ for $G_b = G \frac{1}{\tau s + 1}$ (Answer: 0.15).
- (c) Uncertain pole: Find the range of a for $G_c = \frac{1}{s+a}$ (Answer: 0.8 to 1.33).
- (d) Uncertain pole (time constant form): Find the range of T for $G_d = \frac{1}{Ts+1}$ (Answer: 0.7 to 1.5).
- (e) Neglected resonance: Find the range of ζ for $G_e = G \frac{1}{(s/70)^2 + 2\zeta(s/70) + 1}$ (Answer: 0.02 to 0.8).
- (f) Neglected dynamics: Find the largest integer m for $G_f = G \left(\frac{1}{0.01s+1} \right)^m$ (Answer: 13).
- (g) Neglected RHP-zero: Find the largest τ_z for $G_g = G \frac{-\tau_z s + 1}{\tau_z s + 1}$ (Answer: 0.07). These results imply that a control system which meets given stability and performance requirements for all plants in Π , is also guaranteed to satisfy the same requirements for the above plants G_a, G_b, \dots, G_g .
- (h) Repeat the above with a new nominal plant $G = 1/(s-1)$ (and with everything else the same except $G_d = 1/(Ts-1)$). (Answer: Same as above).

Solution.

- (a) $l_I(\omega) = |1 - e^{-j\omega\theta}|$. When $\theta = 0.13$ $l_I(\omega)$ just touches $|w_I(j\omega)|$.

- (b) $l_I(\omega) = \left| \frac{j\omega\tau}{j\omega\tau+1} \right|$. When $\tau = 0.16$ $l_I(\omega)$ just touches $|w_I(j\omega)|$.
- (c) $l_I(\omega) = \left| \frac{1-a}{j\omega+a} \right|$. When $0.8 \leq a \leq 1.33$ $l_I(\omega) \leq |w_I(j\omega)|$.
- (d) $l_I(\omega) = \left| \frac{(1-T)j\omega}{j\omega T+1} \right|$. When $0.7 \leq T \leq 1.5$ $l_I(\omega) \leq |w_I(j\omega)|$.
- (e) $l_I(\omega) = \left| \frac{(j\omega/70)^2 + j\omega 2\zeta/70}{(j\omega/70)^2 + j\omega 2\zeta/70 + 1} \right|$. When $0.14 \leq \zeta \leq 5.6$ $l_I(\omega) \leq |w_I(j\omega)|$. Note the answer given in the book is not right. If $G_f = G \frac{1}{(s/70)^2 + 2\zeta(s/70) + 1}$, i.e. the middle term is $2\zeta(s/70)$ not $2\zeta(s/70)$ than the answer given in the book is right.
- (f) $l_I(\omega) = \left| \left(\frac{1}{j0.01\omega+1} \right)^m - 1 \right|$. When $m \leq 13$ $l_I(\omega) \leq |w_I(j\omega)|$.
- (g) $l_I(\omega) = \left| \frac{-j2\tau_z\omega}{j\tau_z\omega+1} \right|$. When $\tau_z \leq 0.07$, $l_I(\omega) \leq |w_I(j\omega)|$.
- (h) If we change $G_c = \frac{1}{s-a}$ then $l_I(\omega)$'s for all plants G_a to G_g are the same as (a) to (g). Thus the answer is the same as above.

Exercise 7.4 Represent the gain uncertainty in (7.54) as multiplicative complex uncertainty with nominal model $G = G_0$ (rather than $G = \bar{k}G_0$ used above).

(a) Find w_I and use the RS-condition $\|w_I T\|_\infty < 1$ to find $k_{\max,3}$. Note that no iteration is needed in this case since the nominal model and thus $T = T_0$ is independent of k_{\max} .

(b) One expects $k_{\max,3}$ to be even more conservative than $k_{\max,2}$ since this uncertainty description is not even tight when Δ is real. Show that this is indeed the case using the numerical values from Example 7.10.

Solution.

- (a) Let $k_p G = G(1 - w_I \Delta)$, $k_p \in [1, k_{\max,3}]$ and $|\Delta| \leq 1$. Then $|1 - k_{\max,3}| = \|w_I \Delta\|_\infty$. This leads to $\|w_I\|_\infty = k_{\max,3} - 1$, so $k_{\max,3} = (1/\|T\|_\infty) + 1$.
- (b) Numerically we can get $\|T_0\|_\infty = 1.79$. So $k_{\max,3} = 1.56$ (no iteration needed in this case).

Exercise 7.6 Also derive, from $|w_P S| + |w_I T| < 1$, the following necessary bounds for RP (which must be satisfied)

$$|L| > \frac{|w_P| - 1}{1 - |w_I|}, \quad (\text{for } |w_P| > 1 \text{ and } |w_I| < 1)$$

$$|L| < \frac{1 - |w_P|}{|w_I| - 1}, \quad (\text{for } |w_P| < 1 \text{ and } |w_I| > 1)$$

(Hint: Use $|1 + L| \leq 1 + |L|$.)

Solution. $|w_P S| + |w_I T| < 1 \Leftrightarrow |w_P| + |w_I L| < |1 + L| \leq 1 + |L| \Rightarrow |w_P| - 1 < |L| - |w_I| \cdot |L| = (1 - |w_I|)|L|$. So, if $|w_I| < 1$ and $|w_P| > 1$ then $|L| > \frac{|w_P| - 1}{1 - |w_I|}$, and if $|w_P| < 1$ and $|w_I| > 1$ then $|L| < \frac{1 - |w_P|}{|w_I| - 1}$.

Exercise 7.7 Consider a “true” plant

$$G'(s) = \frac{3e^{-0.1s}}{(2s+1)(0.1s+1)^2}$$

(a) Derive and sketch the additive uncertainty weight when the nominal model is $G(s) = 3/(2s+1)$.

(b) Derive the corresponding robust stability condition.

(c) Apply this test for the controller $K(s) = k/s$ and find the values of k that yield stability. Is this condition tight?

Solution.

(a) Based on a plot we find that $e^{-0.3s}/(0.1s+1)^2 - 1 \approx 0.3s/(0.1s+1)$ and $w_A(s) = \frac{0.9s}{(2s+1)(0.1s+1)}$.

(b) Using (7.12), the RS condition (7.34) can be derived from (7.34): $|T| < |G|/|w_A|$.

(c) $L = GK = \frac{3k}{s(2s+1)}$ and $T = L/(1+L) = \frac{3k}{2s^2+s+3k}$. So, $|T| < |G|/|w_A|$ leads to $|\frac{3k}{2(j\omega)^2+j\omega+3k}| < |\frac{j0.1\omega+1}{j0.3\omega}|$. This gives $k \leq 1$. This condition is tight.

Exercise 7.9 Consider again the system in Figure 7.18. What kind of uncertainty might w_u and Δ_u represent?

Solution. w_u may seem to represent some additive uncertainty, but actually it represents inverse multiplicative (“pole”) uncertainty. (This may be seen by moving the point where the signal goes to w_u to just after the block for w_p).

Exercise 7.11 Parametric gain uncertainty. We showed in Example 7.1 how to represent scalar parametric gain uncertainty $G_p(s) = k_p G_0(s)$ where

$$k_{\min} \leq k_p \leq k_{\max} \quad (7.101)$$

as multiplicative uncertainty $G_p = G(1 + w_I \Delta_I)$ with nominal model $G(s) = \bar{k}G_0(s)$ and uncertainty weight $w_I = r_k = (k_{\max} - k_{\min})/(k_{\max} + k_{\min})$. Δ_I is here a real scalar, $-1 \leq \Delta_I \leq 1$. Alternatively, we can represent gain uncertainty as inverse multiplicative uncertainty:

$$\Pi_{iI} : G_p(s) = G(s)(1 + w_{iI}(s)\Delta_{iI})^{-1}; \quad -1 \leq \Delta_{iI} \leq 1 \quad (7.102)$$

with $w_{iI} = r_k$ and $G(s) = k_i G$ where

$$k_i = 2 \frac{k_{\min} k_{\max}}{k_{\max} + k_{\min}} \quad (7.103)$$

(a) Derive (7.102) and (7.103). (Hint: The gain variation in (7.101) can be written exactly as $k_p = k_i/(1 - r_k \Delta)$.)

(b) Show that the form in (7.102) does not allow for $k_p = 0$.

(c) Discuss why (b) may be a possible advantage.

Solution.

(a) Let $k_p = k_i(1 + r_k \Delta)^{-1}$. If $\Delta = 1$ then $k_p = k_{\min}$, and if $\Delta = -1$ then $k_p = k_{\max}$. Solving the equations:

$$\begin{aligned} k_{\min}(1 + r_k) &= k_i, \\ k_{\max}(1 - r_k) &= k_i, \end{aligned}$$

gives that

$$\begin{aligned} r_k &= \frac{k_{\max} - k_{\min}}{k_{\max} + k_{\min}}, \\ k_i &= 2 \frac{k_{\max} k_{\min}}{k_{\max} + k_{\min}}. \end{aligned}$$

Inserting k_p into $G_p(s) = k_p G_0(s)$ and letting $w_I = r_k$ leads to (7.102) and (7.103).

(b) Since $k_i \neq 0$, $k_p = 0$ implies $1 + r_k \Delta = \infty$. But this is impossible when $-1 \leq \Delta \leq 1$. Thus $k_p = 0$ is not allowed.

(c) Usually the gain CANNOT be zero physically, so using an uncertainty description where this is not possible may be an advantage. However, note that the inverse gain form may allow for k_p being infinite which is also impossible physically.

8

ROBUST STABILITY AND PERFORMANCE ANALYSIS FOR MIMO SYSTEMS

Exercise 8.1 The uncertain plant in (8.7) may be represented in the additive uncertainty form $G_p = G + W_2 \Delta_A W_1$ where $\Delta_A = \delta$ is a single scalar perturbation. Find W_1 and W_2 .

Solution.

$$W_2 = \begin{bmatrix} w \\ -w \end{bmatrix}, \quad W_1 = [1 \quad -1].$$

Exercise 8.3 Obtain H in Figure 8.6 for the uncertain plant in Figure 7.20(b).

Solution.

$$\begin{aligned} H_{11} &= \begin{bmatrix} w_1 & w_1 G \\ 0 & 0 \end{bmatrix}, & H_{12} &= \begin{bmatrix} w_1 G \\ w_2 \end{bmatrix} \\ H_{21} &= [I \quad G], & H_{22} &= G \end{aligned}$$

Exercise 8.4 Show in detail how P in (8.29) is derived.

Solution. From Figure 8.7 it can be obtained that:

$$\begin{aligned} y_\Delta &= W_I u \\ z &= -W_P v \\ v &= -w - Gu - u_\Delta \end{aligned}$$

So,

$$\begin{bmatrix} y_\Delta \\ z \\ v \end{bmatrix} = \begin{bmatrix} 0 & 0 & W_I \\ W_P G & W_P & W_P G \\ -G & -I & -G \end{bmatrix} \begin{bmatrix} u_\Delta \\ w \\ u \end{bmatrix}.$$

Exercise 8.6 Derive N in (8.32) from P in (8.29) using the lower LFT in (8.2). You will note that the algebra is quite tedious, and that it is much simpler to derive N directly from the block diagram as described above.

Solution.

$$\begin{aligned}
N &= P_{11} + P_{12}K(I - P_{22}K)^{-1}P_{21} \\
&= \begin{bmatrix} 0 & 0 \\ W_P G & W_P \end{bmatrix} + \begin{bmatrix} W_I \\ W_P G \end{bmatrix} K(I + GK)^{-1} \begin{bmatrix} -G & -I \end{bmatrix} \\
&= \begin{bmatrix} 0 & 0 \\ W_P G & W_P \end{bmatrix} + \begin{bmatrix} -W_I K S G & -W_I K \\ -W_P G K S G & -W_P G K S \end{bmatrix} \\
&= \begin{bmatrix} -W_I K S G & -W_I K S \\ W_P G(I - K S G) & W_P(I - G K S) \end{bmatrix}
\end{aligned}$$

where $S = (I + GK)^{-1}$. Using the identities $I - GKS = I - T = S = (I + GK)^{-1}$, and $I - KSG = (I + KG)^{-1}$, it finally yields the desired matrix N .

Exercise 8.8 Find P for the uncertain system in Figure 7.18.

Solution.

$$P = \begin{bmatrix} -w_u & -w_u & -w_u G \\ w_P & w_P & w_P G \\ -I & -I & -G \end{bmatrix}$$

Exercise 8.10 Find the interconnection matrix N for the uncertain system in Figure 7.18. What is M ?

Solution.

$$N = \begin{bmatrix} -w_u(I + GK)^{-1} & -w_u(I + GK)^{-1} \\ w_P(I + GK)^{-1} & w_P(I + GK)^{-1} \end{bmatrix}$$

So, $M = N_{11} = -w_u(I + GK)^{-1}$.

Exercise 8.12 $M\Delta$ -structure for combined input and output uncertainties. Consider the block diagram in Figure 8.8 where we have both input and output multiplicative uncertainty blocks. The set of possible plants is given by

$$G_p = (I + W_{2O}\Delta_O W_{1O})G(I + W_{2I}\Delta_I W_{1I}) \quad (8.33)$$

where $\|\Delta_I\|_\infty \leq 1$ and $\|\Delta_O\|_\infty \leq 1$. Collect the perturbations into $\Delta = \text{diag}\{\Delta_I, \Delta_O\}$ and rearrange Figure 8.8 into the $M\Delta$ -structure in Figure 8.3 Show that

$$M = \begin{bmatrix} W_{1I} & 0 \\ 0 & W_{1O} \end{bmatrix} \begin{bmatrix} -T_I & -KS \\ SG & -T \end{bmatrix} \begin{bmatrix} W_{2I} & 0 \\ 0 & W_{2O} \end{bmatrix} \quad (8.34)$$

Solution. Since $N = P_{11} + P_{12}K(I + GK)^{-1}P_{21}$ and $M = N_{11}$, it yields:

$$\begin{aligned}
M &= \begin{bmatrix} 0 & 0 \\ W_{1O} & W_{2I} \end{bmatrix} + \begin{bmatrix} W_{1I} \\ W_{1O} G \end{bmatrix} K(I + GK)^{-1} \begin{bmatrix} -GW_{2I} & -W_{2O} \end{bmatrix} \\
&= \begin{bmatrix} -W_{1I}K(I + GK)^{-1}GW_{2I} & -W_{1I}K(I + GK)^{-1}W_{2O} \\ W_{1O}G(I + GK)^{-1}W_{2I} & -W_{1O}GK(I + GK)^{-1}W_{2O} \end{bmatrix} \\
&= \begin{bmatrix} W_{1I} & 0 \\ 0 & W_{1O} \end{bmatrix} \begin{bmatrix} -T_I & -KS \\ SG & -T \end{bmatrix} \begin{bmatrix} W_{2I} & 0 \\ 0 & W_{2O} \end{bmatrix}
\end{aligned}$$

Exercise 8.13 Consider combined multiplicative and inverse multiplicative uncertainty at the output, $G_p = (I - \Delta_{iO}W_{iO})^{-1}(I + \Delta_O W_O)G$, where we choose to norm-bound the combined uncertainty, $\|[\Delta_{iO} \ \Delta_O]\|_\infty \leq 1$. Draw a block diagram of the uncertain plant, and derive a necessary and sufficient condition for robust stability of the closed-loop system.

Solution. A block diagram of the uncertain plant is shown in Fig. 8.13. From the diagram it

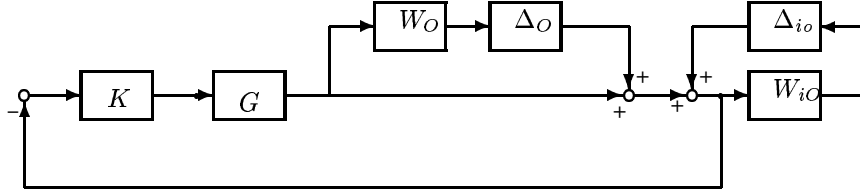

Fig. 8.13 Combined output uncertainties for Exercise 8.13

can be obtained that

$$M = \begin{bmatrix} W_{iO}S \\ W_OT \end{bmatrix}.$$

According to (8.64) the RS condition is:

$$\|M\|_\infty < 1.$$

Exercise 8.15 (continued from Example 8.7). (b) For M in (8.98) and a diagonal Δ show that $\mu(M) = |a| + |b|$ using the lower “bound” $\mu(M) = \max_U \rho(MU)$ (which is always exact). (Hint: Use $U = \text{diag}\{e^{j\phi}, 1\}$ (the blocks in U are unitary scalars, and we may fix one of them equal to 1).) (c) For M in (8.98) and a diagonal Δ show that $\mu(M) = |a| + |b|$ using the upper bound $\mu(M) \leq \min_D \bar{\sigma}(DM D^{-1})$ (which is exact in this case since D has two “blocks”).

Solution. (b) The 2×2 matrix MU is singular and its non-zero eigenvalue is then given by its trace (Fact 1 in Appendix A.2.1). We then get

$$\mu(M) = \max_\phi \rho \begin{bmatrix} ae^{j\phi} & a \\ be^{j\phi} & b \end{bmatrix} = \max_\phi |ae^{j\phi} + b|$$

The sum of two complex numbers is maximized when they are in the same direction, and since we have freedom to select the direction (phase) of the first term, we get $\mu(M) = |a| + |b|$.

(c) Use $D = \text{diag}\{d, 1\}$. Since $DM D^{-1}$ is a singular matrix we have from (A.37) that

$$\bar{\sigma}(DM D^{-1}) = \bar{\sigma} \begin{bmatrix} a & da \\ \frac{1}{d}b & b \end{bmatrix} = \sqrt{|a|^2 + |da|^2 + |b/d|^2 + |b|^2} \quad (8.100)$$

which we want to minimize with respect to d . The solution is $d = \sqrt{|a|/|b|}$ which gives $\mu(M) = \sqrt{|a|^2 + 2|ab| + |b|^2} = |a| + |b|$.

Exercise 8.18 Let a, b, c and d be complex scalars. Show that for

$$\Delta = \text{diag}\{\delta_1, \delta_2\} : \quad \mu \begin{bmatrix} ab & ad \\ bc & cd \end{bmatrix} = \mu \begin{bmatrix} ab & ab \\ cd & cd \end{bmatrix} = |ab| + |cd| \quad (8.103)$$

Does this hold when Δ is scalar times identity, or when Δ is full? (Answers: No and No).

Solution. Using (8.86), and letting $U = \text{diag}\{e^{j\phi}, 1\}$ we can get

$$\begin{bmatrix} ab & ad \\ bc & cd \end{bmatrix} U = \begin{bmatrix} abe^{j\phi} & ad \\ bce^{j\phi} & cd \end{bmatrix},$$

which is singular. Thus

$$\begin{aligned} \mu \begin{bmatrix} ab & ad \\ bc & cd \end{bmatrix} &= \max_U \rho \left(\begin{bmatrix} ab & ad \\ bc & cd \end{bmatrix} U \right) \\ &= \max_{\phi} \left| \text{tr} \left(\begin{bmatrix} abe^{j\phi} & ad \\ bce^{j\phi} & cd \end{bmatrix} \right) \right| \\ &= \max_{\phi} |abe^{j\phi} + cd| \\ &= |ab| + |cd|. \end{aligned}$$

The second equality has been proven in Example 8.7. When $\Delta = \delta I$, $U = e^{j\phi} I$, we have essentially no degrees of freedom and $\mu(M) = \rho(M) = |ab+cd|$ (which is generally smaller). When Δ is full, U is a general unitary matrix, and $\mu(M) = \bar{\sigma}(M)$ which is generally larger. So the answer for the last question is also NO.

Exercise 8.20 If (8.94) were true for any structure of Δ then it would imply $\rho(AB) \leq \bar{\sigma}(A)\rho(B)$. Show by a counterexample that this is not true.

Solution. Select $A = \begin{bmatrix} 1 & 0 \\ 10 & 1 \end{bmatrix}$, $B = \begin{bmatrix} 1 & 10 \\ 0 & 1 \end{bmatrix}$. Then $\rho(AB) = 102$, $\bar{\sigma}(A) = 10$, and $\rho(B) = 1$, so $\rho(AB) > \bar{\sigma}(A)\rho(B)$.

Exercise 8.22 Consider the plant $G(s)$ in (8.108) which is ill-conditioned with $\gamma(G) = 70.8$ at all frequencies (but note that the RGA-elements of G are all about 0.5). With an inverse-based controller $K(s) = \frac{0.7}{s} G(s)^{-1}$, compute μ for RP with both diagonal and full-block input uncertainty using the weights in (8.133). The value of μ is much smaller in the former case.

Solution. The μ curves for diagonal and full-block input uncertainty are shown in Fig. 8.22. The value of μ for diagonal uncertainty is much smaller than that of the case discussed in Section 8.11.3.

Exercise 8.24 Explain why the optimal μ -value would be the same if in the model (8.144) we changed the time constant of 75 [min] to another value. Note that the μ -iteration itself would be affected.

Solution. The optimal μ -curve as a function of frequency is flat, i.e. the optimal μ is almost a constant (μ -value) over a wide range of frequencies. In the model (8.144), the change of the time constant can be treated as a frequency scaling change, while the optimal μ -value is independent of frequency. Thus it would be the same.

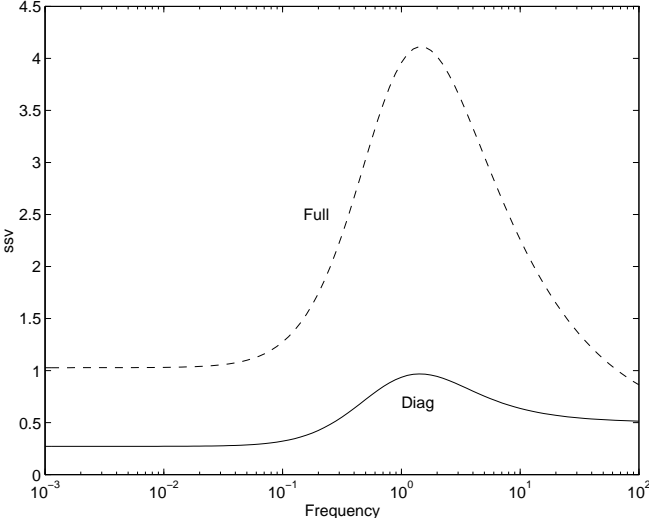

Fig. 8.22. μ curves for diagonal and full uncertainty in Exercise 8.22

9

CONTROLLER DESIGN

Exercise 9.1 Show that the closed-loop objectives 1 to 6 can be approximated by the open-loop objectives 1 to 6 at the specified frequency ranges.

Solution.

1. When $\bar{\sigma}(GK) \gg 1$, $S = (I + GK)^{-1} \approx (GK)^{-1}$. So the close-loop objective 1, making $\bar{\sigma}(S)$ small, can be approximated by the open-loop objective 1, making $\bar{\sigma}(GK)$ large.
2. When $\bar{\sigma}(GK) \ll 1$, $T = GK(I + GK)^{-1} \approx GK$. So the closed-loop objective 2, making $\bar{\sigma}(T)$ small, can be approximated by the open-loop objective 2, making $\bar{\sigma}(GK)$ small.
3. $\bar{\sigma}(GK) \gg 1 \Rightarrow T = GK(I + GK)^{-1} \approx I$. So $\bar{\sigma}(GK)$ small $\Rightarrow \bar{\sigma}(T) \approx \underline{\sigma}(T) \approx 1$.
4. $\bar{\sigma}(GK) \ll 1 \Rightarrow KS = K(I + GK)^{-1} \approx K$. Thus, $\bar{\sigma}(K)$ small $\Rightarrow \bar{\sigma}(KS)$ small.
5. See 4.
6. $\bar{\sigma}(GK) \ll 1 \Rightarrow T = GK(I + GK)^{-1} \approx GK$. Thus, $\bar{\sigma}(GK)$ small $\Rightarrow \bar{\sigma}(T)$ small.

Exercise 9.6 For the cost function

$$\left\| \begin{bmatrix} W_1 S \\ W_2 T \\ W_3 K S \end{bmatrix} \right\|_{\infty} \quad (9.58)$$

formulate a standard problem, draw the corresponding control configuration and give expressions for the generalized plant P .

Solution. The control configuration is shown in Fig. 9.6. From the figure, the generalized plant P can be derived as:

$$\begin{aligned} P_{11} &= \begin{bmatrix} W_1 \\ 0 \\ 0 \end{bmatrix}, & P_{12} &= \begin{bmatrix} -W_1 G \\ W_2 G \\ W_3 \end{bmatrix}, \\ P_{21} &= I, & P_{22} &= -G. \end{aligned}$$

Exercise 9.8 Design an \mathcal{H}_{∞} loop-shaping controller for the disturbance process in (9.75) using the weight W_1 in (9.76), i.e. generate plots corresponding to those in Figure 9.18. Next, repeat the design with $W_1 = 2(s + 3)/s$ (which results in an initial G_s which would yield closed-loop instability with $K_c = 1$). Compute the gain and phase margins and compare the disturbance and reference responses. In both cases find ω_c and use (2.45) to compute the maximum delay that can be tolerated in the plant before instability arises.

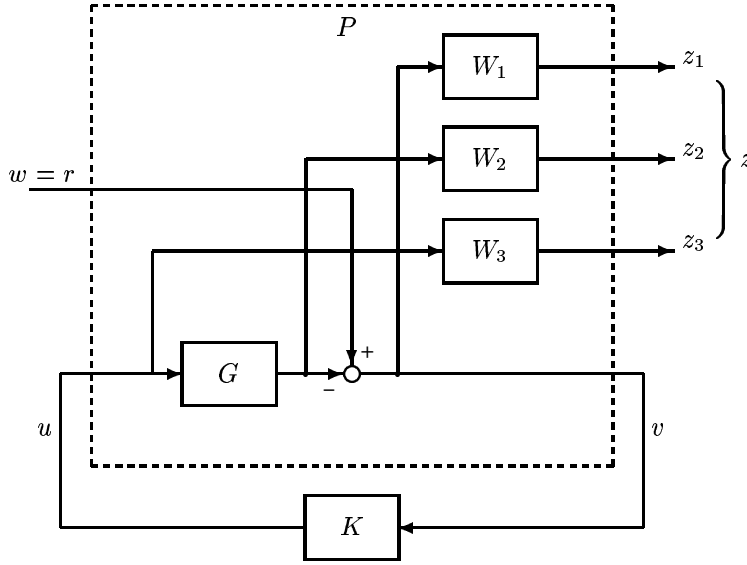
Fig. 9.6 Control configuration for $S/T/KS$ optimization problem

Solution. The loop shapes, disturbance response and reference response of the system using the \mathcal{H}_∞ loop-shaping controller designed with $W_1 = 2(s + 3)/s$ are shown in Fig. 9.8. It is shown that the initial G_s would yield closed-loop instability with $K_c = 1$ (dashed-line). The gain margin of this design is 2.95, phase margin is 44.2° . $\omega_c = 15.8$ rad/s. Thus the maximum delay is $\text{PM}/\omega_c = 0.049$ s which can be tolerated in the plant before instability.

Exercise 9.10 Show that the Hanus form of the weight W_1 in (9.109) simplifies to (9.108) when there is no saturation i.e. when $u_a = u$.

Solution. Let $u = G_1 u_s + G_2 u_a$, where

$$G_1 \stackrel{s}{=} \left[\begin{array}{c|c} \frac{A_w - B_w D_w^{-1} C_w}{C_w} & 0 \\ \hline & D_w \end{array} \right] = D_w$$

$$G_2 \stackrel{s}{=} \left[\begin{array}{c|c} \frac{A_w - B_w D_w^{-1} C_w}{C_w} & B_w D_w^{-1} \\ \hline & 0 \end{array} \right]$$

If $u_a = u$, then $u = (I - G_2)^{-1} G_1 u_s$. We have,

$$I - G_2 \stackrel{s}{=} \left[\begin{array}{c|c} \frac{A_w - B_w D_w^{-1} C_w}{C_w} & -B_w D_w^{-1} \\ \hline & I \end{array} \right]$$

and (see (4.27))

$$(I - G_2)^{-1} \stackrel{s}{=} \left[\begin{array}{c|c} A_w & -B_w D_w^{-1} \\ \hline -C_w & I \end{array} \right]$$

Thus,

$$(I - G_2)^{-1} G_1 \stackrel{s}{=} \left[\begin{array}{c|c} A_w & -B_w D_w^{-1} D_w \\ \hline -C_w & D_w \end{array} \right] \stackrel{s}{=} \left[\begin{array}{c|c} A_w & B_w \\ \hline C_w & D_w \end{array} \right]$$

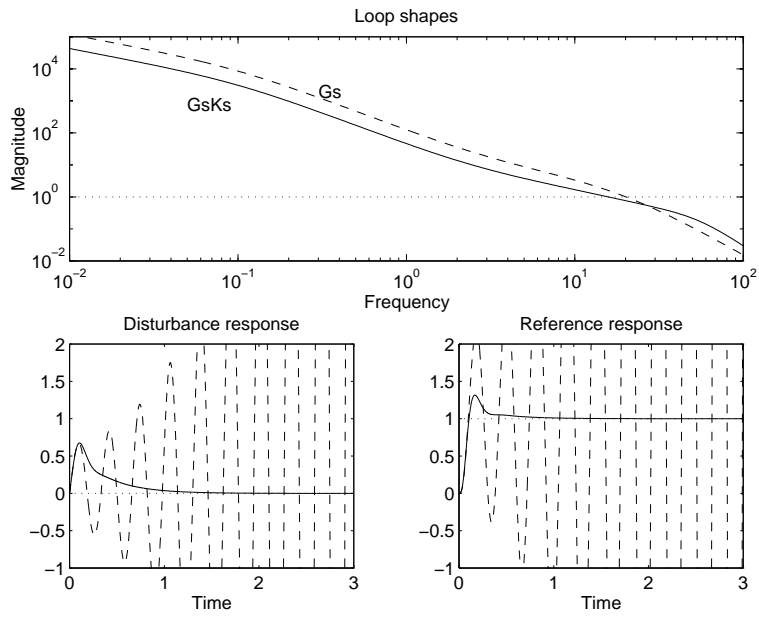

Fig. 9.8 Loop shaping design for Exercise 9.8

10

CONTROL STRUCTURE DESIGN

Exercise 10.2 Suppose that we want to minimize the LQG-type objective function, $J = x^2 + ru^2$, $r > 0$, where the steady-state model of the system is

$$x + 2u - 3d = 0$$

$$y_1 = 2x, \quad y_2 = 6x - 5d, \quad y_3 = 3x - 2d$$

Which measurement would you select as a controlled variable for $r = 1$? How does your conclusion change with variation in r ? Assume unit implementation error for all measurements.

Solution. For this system, we have that $J = (3d - 2u)^2 + ru^2$.

So, $J_u = (8 + 2r)u - 12d$ and $u_{opt} = \frac{6}{4+r}d$.

Also, $J_{uu} = 8 + 2r$ and $J_{ud} = -12$.

The state-space model of the system can be written as:

$$y_1 = -4u + 6d, \quad y_2 = -12u + 13d, \quad y_3 = -6u + 7d$$

So, the linearized models for the three measured variables are:

$$\begin{aligned} y_1: & \quad G_{d1}^y = -4, & G_{u1}^y &= 6 \\ y_2: & \quad G_{d2}^y = -12, & G_{u2}^y &= 13 \\ y_3: & \quad G_{d3}^y = -6, & G_{u3}^y &= 7 \end{aligned}$$

Following the singular value procedure (page 400):

1. The input is scaled by the factor $1/\sqrt{(\partial^2 J/\partial u^2)_{opt}} = 1/\sqrt{8+2r}$ such that a unit deviation in each input from its optimal value has the same effect on the cost function J .
2. The maximum setpoint error due to variations in disturbances is given as $e_{opt,i} = G_i^y J_{uu}^{-1} J_{ud} - G_{di}^y$. Then, for $z = y_1$, $e_{opt,1} = (-4) \cdot \frac{1}{8+2r} \cdot (-12) - (6) = \frac{48}{8+2r} - 6$ and similarly, $e_{opt,2} = \frac{144}{8+2r} - 13$ and $e_{opt,3} = \frac{72}{8+2r} - 7$.
3. For each candidate controlled variable the implementation error is $n^z = 1$.
4. The expected variation ("span") for $z = y_1$ is $|e_{opt,i}| + |n_1^y| = |\frac{48}{8+2r} - 6| + 1$. Similarly, for $z = y_2$ and $z = y_3$, the spans are $|\frac{144}{8+2r} - 13| + 1$ and $|\frac{72}{8+2r} - 7| + 1$, respectively.

5. The scaled gain matrices and the worst-case losses are

$$\begin{aligned} z = y_1 : |G'_1| &= \frac{1}{|\frac{48}{8+2r}-6|+1} \cdot 4/\sqrt{8+2r}; \\ z = y_2 : |G'_2| &= \frac{1}{|\frac{144}{8+2r}-13|+1} \cdot 12/\sqrt{8+2r}; \\ z = y_3 : |G'_3| &= \frac{1}{|\frac{72}{8+2r}-7|+1} \cdot 6/\sqrt{8+2r} \end{aligned}$$

These scaled gain matrices can be plotted for different values of r (see Figure 10.2).

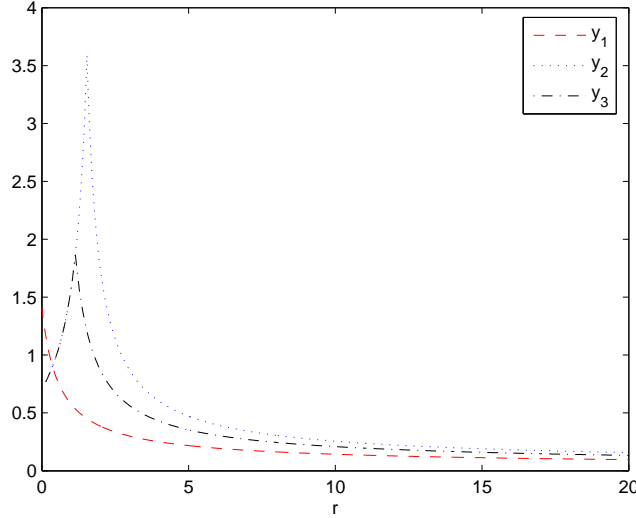

Fig. 10.2. Norm of scaled gain matrix.

So, we can conclude that it is better to choose y_1 when $r < 0.364$. If $0.364 < r < 1.14$, then we can choose both y_2 or y_3 . For $r > 1.14$, y_2 is the best choice.

Exercise 10.4 Show that for a system with a single unstable pole, (10.23) represents the least achievable value of $\|KS\|_\infty$. (Hint: Rearrange (5.31) on page 178 using the definition of pole vectors.)

Solution. From (5.31):

$$\|KS\|_\infty \geq |G_s^{-1}(p)| \quad (10.31)$$

By definition of pole vectors:

$$G(s) = \frac{1}{q^T t} \frac{y_p u_p^H}{s-p} + N(s)$$

Also, the stable version of $G(s)$ with the RHP-pole at $s = p$ mirrored across the imaginary axis is:

$$G_s(p) = \frac{(s-p)}{(s+p)} G(p)$$

Then, we have

$$\|G_s(p)\|_2 = \left\| \frac{1}{q^T t} \cdot \frac{y_p u_p^T}{s+p} + \frac{s-p}{s+p} N(s) \right\|_{2(s=p)}$$

or

$$G_s(p) = \frac{\|y_p\|_2 \cdot \|u_p\|_2}{2p \cdot |q^T t|}$$

Then,

$$\|KS\|_\infty \geq |G_s^{-1}(p)| = \frac{2p \cdot |q^T t|}{\|y_p\|_2 \cdot \|u_p\|_2}$$

Exercise 10.5 For systems with multiple unstable poles, the variables can be selected sequentially using the pole vector approach by stabilizing one real pole or a pair of complex poles at a time. Usually, the selected variable does not depend on the controllers designed in the previous steps. Verify this for each of the following two systems:

$$G_1(s) = Q(s) \cdot \begin{bmatrix} 10 & 2 & 1 \\ 12 & 1.5 & 5.01 \end{bmatrix} \quad G_2(s) = Q(s) \cdot \begin{bmatrix} 10 & 2 & 1 \\ 12 & 1 & 1.61 \end{bmatrix}$$

$$Q(s) = \begin{bmatrix} 1/(s-1) & 0 \\ 0 & 1/(s-0.5) \end{bmatrix}$$

(Hint: Use simple proportional controllers for stabilization of $p = 1$ and evaluate the effect of change of controller gain on pole vectors in the second iteration.)

Solution. For $G_1(s)$, the absolute pole vectors are:

$$|Y_p| = \begin{bmatrix} 0.00 & 4.00 \\ \mathbf{4.00} & 0.00 \end{bmatrix} \quad |U_p|^T = \begin{bmatrix} \mathbf{3.000} & 0.375 \\ 1.252 & 2.50 \\ 0.500 & 0.25 \end{bmatrix}$$

So, we choose to select first output y_2 and input u_1 . Afterwards, we can use again the pole vectors to select the next loop, after closing the first one.

$$|Y_p| = [-\mathbf{4.790}] \quad |U_p|^T = \begin{bmatrix} -0.221 \\ -\mathbf{0.737} \end{bmatrix}$$

Then, the first loop will be y_1 and u_3 . The simulation is shown in Figure 10.5(a).

For $G_2(s)$, the absolute pole vectors are:

$$|Y_p| = \begin{bmatrix} 0.00 & 4.00 \\ \mathbf{4.00} & 0.00 \end{bmatrix} \quad |U_p|^T = \begin{bmatrix} \mathbf{3.000} & 0.25 \\ 0.403 & 2.50 \\ 0.500 & 0.25 \end{bmatrix}$$

So, we choose to select first output y_2 and input u_1 . Afterwards, we can use again the pole vectors to select the next loop, after closing the first one.

$$|Y_p| = [\mathbf{4.854}] \quad |U_p|^T = \begin{bmatrix} 0.165 \\ \mathbf{0.265} \end{bmatrix}$$

Then, the first loop will be y_1 and u_3 . The simulation is shown in Figure 10.5(b).

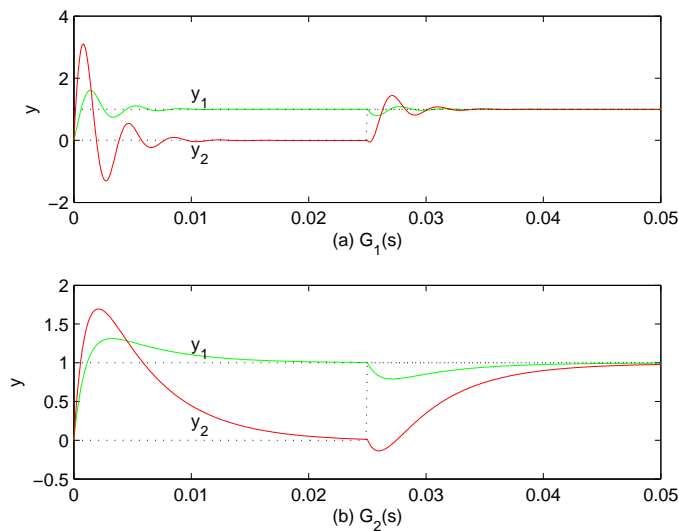

Fig. 10.5. Figure for exercise 10.5.

Exercise 10.9 Draw the block diagrams for the two centralized (parallel) implementations corresponding to Figure 10.10 (in the book).

Solution. See Figure 10.9 (in this solution manual)

Exercise 10.11 Process control application. A practical case of a control system like the one in Figure 10.13 is in the use of a pre-heater to keep the reactor temperature y_1 at a given value r_1 . In this case y_2 may be the outlet temperature from the pre-heater, u_2 the bypass flow (which should be reset to r_3 , say 10% of the total flow), and u_3 the flow of heating medium (steam). Make a process flowsheet with instrumentation lines (not a block diagram) for this heater/reactor process.

Solution. See Fig. 10.11.

Exercise 10.17 (a) Assume that the 4×4 matrix in (A.83) represents the steady-state model of a plant. Show that 20 of the 24 possible pairings can be eliminated by requiring DIC. (b) Consider the 3×3 FCC process in Exercise 6.17 on page 257. Show that the six possible pairings can be eliminated by requiring DIC.

Solution. (a) Applying (10.78) to (A.83), where the RGA is:

$$\Lambda(A_2) = \begin{bmatrix} 6.16 & -0.69 & -7.94 & 3.48 \\ -1.77 & 0.10 & 3.16 & -0.49 \\ -6.60 & 1.73 & 8.55 & -2.69 \\ 3.21 & -0.14 & -2.77 & 0.70 \end{bmatrix}$$

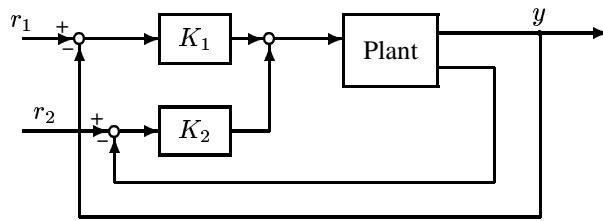

(e) Extra measurements y_2

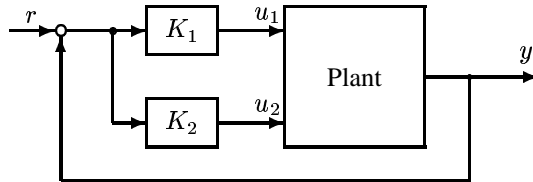

(f) Extra inputs u_2

Fig. 10.9 Centralized implementations

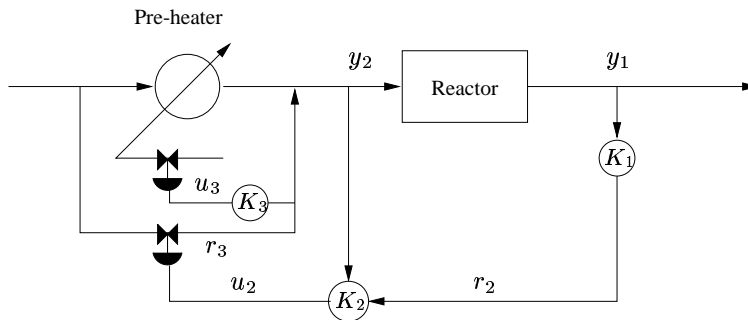

Fig. 10.11. Flowsheet for heater-reactor process.

it can be seen that outputs 1 and 4 can only be paired with inputs 1 and 4 in 2 possible combinations, and that output 2 and 3 can only be paired with inputs 2 and 3 also in 2 possible combinations. Thus only 4 pairings give positive RGA required by DIC and other 20 pairings can be eliminated.

(b) The RGA is:

$$\Lambda(A_2) = \begin{bmatrix} 1.4966 & 0.9855 & -1.4821 \\ -0.4147 & 0.9662 & 0.4485 \\ -0.0819 & -0.9517 & 2.0336 \end{bmatrix}$$

it can be seen that outputs 1 can only be paired with input 1 and input 3 can only be paired with output 3. Thus there is only one pairing that gives positive RGA required by DIC and other 5 pairings can be eliminated.

11

MODEL REDUCTION

Exercise 11.1 *The steady-state gain of a full order balanced system (A, B, C, D) is $D - CA^{-1}B$. Show, by algebraic manipulation, that this is also equal to $D_r - C_r A_r^{-1} B_r$, the steady-state gain of the balanced residualization given by (11.7)–(11.10).*

Solution. Using (A.8) and noting Y in (A.8) is equal to A_r in (11.7), we have

$$\begin{aligned}
 & D - CA^{-1}B \\
 = & D - [C_1 \quad C_2] \begin{bmatrix} A_r^{-1} & -A_r^{-1}A_{12}A_{22}^{-1} \\ -A_{22}^{-1}A_{21}A_r^{-1} & A_{22}^{-1} + A_{22}^{-1}A_{21}A_r^{-1}A_{12}A_{22}^{-1} \end{bmatrix} \begin{bmatrix} B_1 \\ B_2 \end{bmatrix} \\
 = & D - [C_r A_r^{-1} \quad C_2 A_{22}^{-1} - C_r A_r^{-1} A_{12} A_{22}^{-1}] \begin{bmatrix} B_1 \\ B_2 \end{bmatrix} \\
 = & D - C_2 A_{22}^{-1} B_2 - C_r A_r^{-1} (B_1 - A_{12} A_{22}^{-1} B_2) \\
 = & D_r - C_r A_r^{-1} B_r
 \end{aligned}$$

Exercise 11.3 *Is Theorem 11.3 true, if we replace balanced truncation by balanced residualization?*

Solution. Yes, it is still true. Balanced truncation and balanced residualization are related by the bilinear transformation $s \rightarrow s^{-1}$. If $(N(s), M(s))$ is a normalized left-coprime factorization of $G(s)$ then $(N(s^{-1}), M(s^{-1}))$ is a normalized left-coprime factorization of $G(s^{-1})$. Applying Theorem 11.3 to $(N(s^{-1}), M(s^{-1}))$ is equivalent to using balanced residualization with $(N(s), M(s))$.

12

LINEAR MATRIX INEQUALITIES

Exercise 12.1 Let Q be a Hermitian matrix ($Q = Q^H$) having the form $Q = Q_R + jQ_I$. Show that $Q > 0$ if and only if

$$\begin{bmatrix} Q_R & Q_I \\ -Q_I & Q_R \end{bmatrix} > 0 \quad (12.9)$$

Solution. For a complex hermitian matrix Q , $Q > 0$, it implies that $Re(x^H Q x) > 0$, for all x in C^n (C is the set of complex numbers).

Let $Q = Q_r + jQ_i$ and $x = x_r + jx_i$.

Then,

$$Re(x^H Q x) = x_r^T Q_r x_r + x_i^T Q_i x_r - x_r^T Q_i x_r - x_r^T Q_i x_i + x_i^T Q_r x_i > 0$$

which can be written as

$$[x_r \quad x_i]^T \begin{bmatrix} Q_r & Q_i \\ -Q_i & Q_r \end{bmatrix} [x_r \quad x_i] > 0$$

Since this holds for any $[x_r \quad x_i]$, we have

$$\begin{bmatrix} Q_r & Q_i \\ -Q_i & Q_r \end{bmatrix} > 0$$

Exercise 12.3 With reference to Example 12.2, formulate the problem of finding the worst-case (maximum) gain of each of the uncertain systems

$$G_1(s) = \frac{k}{s + \tau}; G_2(s) = \frac{k}{\tau s + 1} \quad (12.51)$$

as LMI problems. Verify your results with the Robust Control toolbox command `wcgain` using numerical values $2 \leq k, \tau \leq 3$.

Solution.

Transfer functions G_1 and G_2 can be easily converted to state-space representation:

$$\dot{x} = Ax + Bu$$

$$y = Cx + Du$$

For G_1 : $A = -\tau$, $B = k$, $C = 1$, and $D = 0$

For G_2 : $A = -\frac{1}{\tau}$, $B = k$, $C = \frac{1}{\tau}$, and $D = 0$

Substituting these A , B , C , and D in (12.30) we get the LMI problem.

The results obtained are similar to using Robust Control toolbox command `wcgain`, i.e., both methods give almost the same upper bounds, as can be seen on the next Table.

	G_1	G_2
wcgain	1.5003	3.0273
LMI	1.5	3.06

13

CASE STUDIES

Exercise 13.1 Repeat the μ -optimal design based on DK -iteration in Section 8.12.4 using the model (13.19).

Solution. Apply the MATLAB program given in Table 8.2 to G in (13.9). After 10 iterations, the resulting controller with 25 states (denoted K_{10} in the following) gives a peak μ -value of 0.8847 (see Fig. 13.1(a)). The final μ -curves for RS, NP and RP with controller K_{10} are shown in Fig. 13.1(b). It is shown that all requirements are well satisfied. The time response of y_1 and y_2 to a filtered setpoint change in y_1 , $r_1 = 1/(5s + 1)$ is shown in Fig. 13.1(c), both for the nominal case (solid line) and for 20% input gain uncertainty (dashed line)

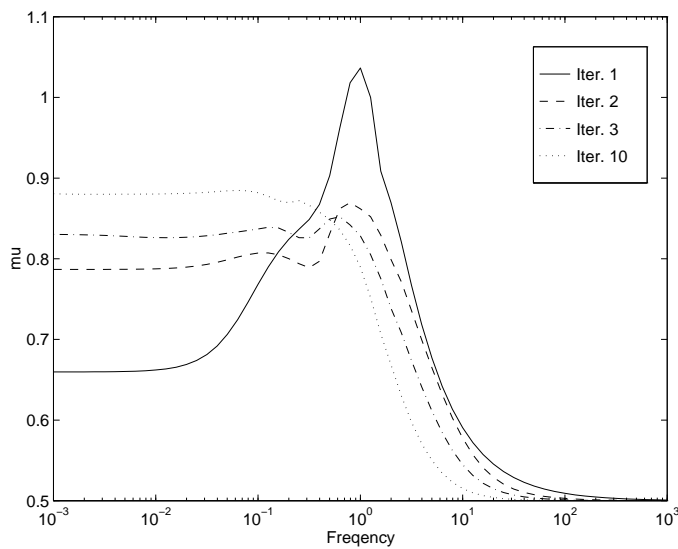

Fig. 13.1(a). Change in μ during DK -iteration.

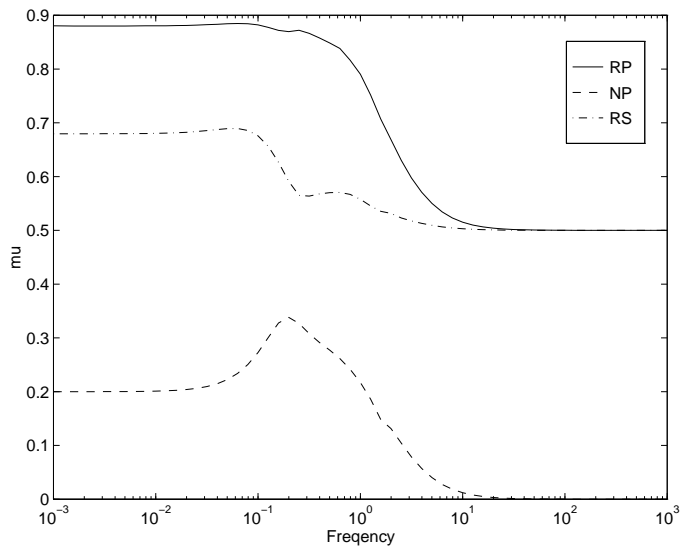

Fig. 13.1(b). -plots with -“optimal” controller K_{10} .

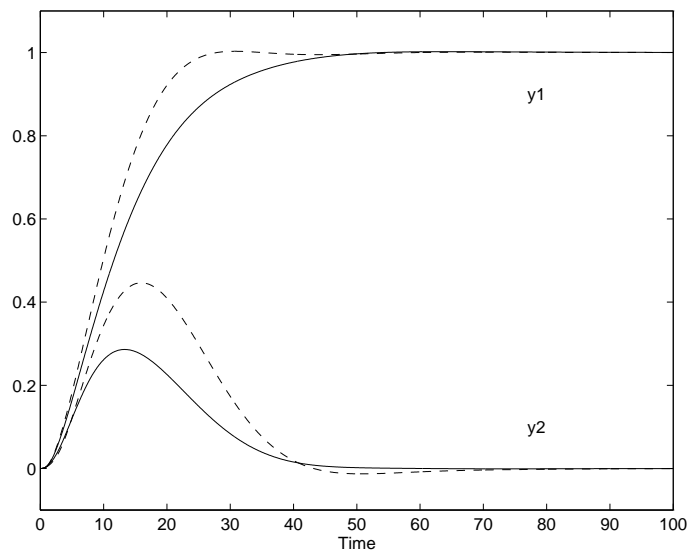

Fig. 13.1(c). Setpoint response for -“optimal” controller K_{10} . Solid line: nominal plant. Dashed line: “worst-case” plant.