

THE DYNAMICS OF LONG-RANGE FINANCIAL ACCUMULATION AND CRISIS

TROND ANDRESEN

Department of Engineering Cybernetics,
The Norwegian University of Science and Technology,
N-7034 Trondheim, NORWAY.

E-mail: Trond.Andresen@itk.ntnu.no

Fax: +47 7359 4599

Keywords: *Economy, finance, simulation, accumulation, crisis.*

DYNAMICS OF LONG-RANGE FINANCIAL ACCUMULATION

ABSTRACT:

A dynamic model of money stock/flow relations for a generic economic agent is developed, and employed to model and discuss the long-range (decades) impact of returns on any form of saved or invested money on a macroeconomy. It is shown that, subject to realistic assumptions about behavior of economic agents, a macro-economic system with positive returns must eventually reach a depression-like economic state. The observed disproportionate growth of financial sectors in recent years is explained by the proposed model. Simulation runs are presented. An indicator for economic fragility is proposed.

Introduction

In Andresen (1996) the long-range financial dynamics of a macroeconomy with asset (mirrored by corresponding debts) accumulation is explored. Some assumptions are made to justify the step of aggregating a network of large numbers of individual agents into one more or less "equivalent" macro-economic agent.

This paper develops a more mathematically precise model, and it presents some simulation results. It will, however, employ the nomenclature and definitions from Andresen (1996). In that representation, the economy is portrayed as a an interconnected network of agents with cash flowing between them. This agent concept is illustrated in Fig. 1.

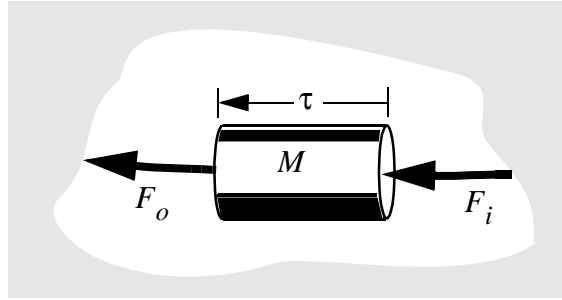

Figure 1. An economic agent

The economic agent may be compared to a "tube". Money arrives at one end and travels through the tube before appearing at the other end τ time units later. Money stock M for the agent is then the volume in the tube at a given instant. For the special case with $F_o = F_i = F =$ constant, we have

$$M = F\tau \tag{1}$$

M may be interpreted as the agent's necessary liquid buffer to handle discrepancies between in- and outgoing cash flows. It may also be interpreted as caused by a necessary *decision time delay* or *circulation time delay* τ for the agent before received cash is paid out again. We may also define a *local velocity of money*:

$$v = 1/\tau \tag{2}$$

The time delay concept clarifies the connection between money stock and money flows. The delay associated with flows in general (as in process plants, pipelines, etc.), will in the case of money be the time a given amount spends between arrival and departure *at a given agent*. Flows *between* agents may be reckoned as immediate. Thus money always resides at some agent. If time delays were very small, one could have immense fluctuations in money flows with minute changes in time delays. Money flows would be more or less decoupled from money stock. In the real world, however, there is some lower limit to this time delay for any representative economic agent. The existence of such limits will be decisive for some of the points to be made later on. We will consider three main types of agents: firms, households and banks.

In the model to be presented, we abstract from the production of goods and services, and consider only the phenomenon of money being passed between agents. This seemingly drastic neglect of physical production will be shown to be acceptable for the points to be made.

The final model is a nonlinear four-state unstable system. Depending on parameter values, the model either converges to (unstable) linear behavior for large t , or the nonlinearities in the system make the system undergo a sudden collapse-like transition to a point where one state is zero. The influence of specific parameters on the bifurcation is explored.

The final model will be developed by involving gradually more realistic assumptions to improve intermediate and simpler models. The stages are: (a) an individual accumulating agent, (b) an aggregate accumulating agent, (c) an aggregate accumulating agent interacting with the remaining indebted part of the economy, (d) adding the effect of insolvencies and liquidity preference among creditors (this makes the system nonlinear), (e) accounting for the tendency of the accumulating sector to invest in itself, (f) accounting for money growth. The last two models will be simulated, and the results discussed.

The single-agent accumulation process

Let us first consider a "generic rentier agent" which is able to accumulate financial assets through the mechanism of compound "interest." In this paper the term "interest" is used in a very wide sense, i.e. any returns from savings or investments, including dividends on stock.

We call this type of agent an "economic black hole." This dramatic choice of term is deliberate. It is made to emphasize the destructive self-reinforcing process that results from the ubiquitous and insatiable demand for real returns on saved (invested) money.

We ignore the part of the "black hole's" cash flows which is directly related to real economic activity. For a household this means ignoring incoming wages and consumption out of incoming wages. For a firm this means ignoring payment for goods or services delivered, and wages paid to employees. (This will be discussed in detail in the section "Microeconomic black holes" below.) Remaining cash flows for the black hole are then incoming and outgoing cash flows which are "financial": Interest and repayment of loans coming in, and new loans and other financial investment going out. Under such assumptions we may, based on the general description in Fig. 1, depict the black hole agent (or generic rentier) as shown at the left in Fig. 2. Other black holes are also indicated.

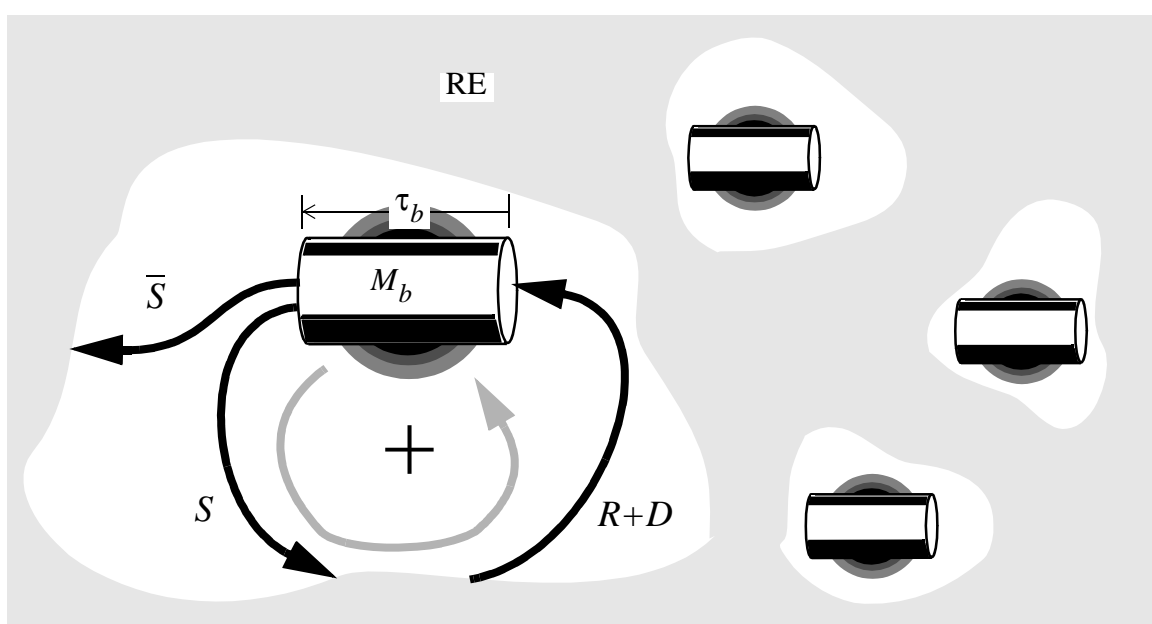

Figure 2. "Black hole" agents

The shaded area and the letters "RE" symbolize "the rest of the economy" which means the aggregate of all non-black-hole-agents, i.e. agents with zero or negative net financial assets. The shaded arrow and the "+" sign depicts positive feedback, which will be explained below. The symbols in Fig. 2 represent different cash flows:

$R + D$ = net incoming cash flow [currency unit / time unit] consisting of interest (R) and repayments of old loans (D).

D may be zero (when assets consist of stock or other types of perpetuities).

S = net outgoing cash flow [c.u./ t.u.] which is invested or lent-out or saved for future returns. Here the use of the term "invest" is in the sense of *allocation of cash for future returns*, not in the sense of actual purchase of capital goods. (This distinction is discussed more closely later on.)

\bar{S} = *non-saving*, i.e. any outgoing cash flow [c.u./ t.u.] which *does not place any obligations on the receiver for future returns*; for consumption (C_b) or for employment of personnel (W_b); $\bar{S} = C_b + W_b$

Furthermore, let -

A_b = net financial assets of the black hole; which are invested or lent-out or saved [currency unit].

M_b = money stock for the black hole, i.e. deposits and currency [currency unit].

Total net financial assets of the black hole are then $A_b + M_b$.

τ_b = circulation time delay for the agent [time unit].

All the above entities vary continuously as functions of time, but the time variable t is sometimes omitted for convenience in the equations to follow. All amounts and flows are in nominal currency. We also define -

i = interest rate [% / time unit].

d = rate of repayment as a percentage of net financial assets A_b [% / t.u.].

s = the black hole's propensity to save out of financial income.

\bar{s} = the black hole's *propensity not to save* (i.e. to consume, and employ personell) out of financial income; we have $s + \bar{s} = 1$.

The "propensity not to save" is essentially the same as the propensity to consume. But it is convenient for the models to be constructed that we also allow the black hole agent to directly employ people, in addition to the agent's consumption.

The net cash flow going into the black hole due to interest and repayments is

$$R + D = iA_b + dA_b = (i + d)A_b \quad (3)$$

$$\text{Part of this, } S[t] = \bar{s}(i + d)A_b[t - \tau_b] \quad (4)$$

is paid out for consumption and employment of personnel, after a circulation time delay τ_b .

$$\text{Another part, } S[t] = s(i + d)A_b[t - \tau_b] \quad (5)$$

is financially re-invested or lent-out for future returns. A_b however, is decreased by the repayment of old loans, by a term $d \cdot A_b$. Money stock M_b is simply the effect of the black hole's receiving financial income, but delaying payments by τ_b time units.

From the above we get the first-order homogeneous linear differential equations

$$\dot{M}_b[t] = (i + d)(A_b[t] - A_b[t - \tau_b]) \quad (6)$$

$$\dot{A}_b[t] = -dA_b[t] + s(i + d)A_b[t - \tau_b] \quad (7)$$

A block diagram in the time domain representing Eq. 7 is shown in Fig. 3.

1. Brackets [] are employed to indicate "a function of", as opposed to parentheses () and braces { } which imply summation before multiplication.

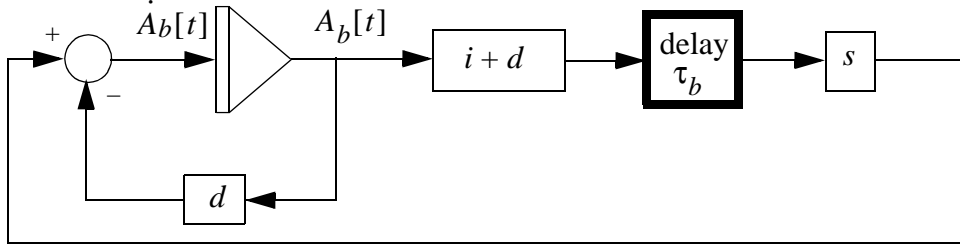

Figure 3. Financial accumulation block diagram

(The triangular icon symbolizes integration. Blocks which imply that the output is the product of the input with the factor inside the block, are shown with thin outlines. Thick outlines imply time delays or nonlinear relations. We will introduce the latter later on).

We now assume that the time delay τ_b is negligible (in the order of weeks) compared to the time constant of asset growth (in the order of many years). Then Eq. 7 may be simplified to

$$\dot{A}_b[t] = \{-d + s(i + d)\}A_b[t] \quad (8)$$

In Eq. 8 the eigenvalue is $\lambda = -d + s(i + d)$ (9)

Assuming that d, s, i are constant, the solution of Eq. 8 is

$$A_b[t] = A_b[t_0]e^{\lambda(t-t_0)} \quad (10)$$

We have exponential growth in A_b for $\lambda > 0$, i.e. financial accumulation.

Employing Eq. 9, the inequality $\lambda > 0$ may be expressed in the three alternative forms:

$$s > \frac{d}{i + d} \quad (11)$$

$$\bar{s} < \frac{i}{i + d} \quad (12)$$

$$is > (1 - s)d \quad (13)$$

A large enough term " is " in Eq. 13 gives the positive feedback depicted in Fig. 2; we have a black hole. From Eq. 11 we see that if $d = 0$, accumulation will take place for any $s > 0$.

Verbally this may be expressed as "When one saves at all when the incoming cash flow is

interest only, one's assets will grow". This special case suggests that if the assets in an economy are in the main of a type which are not repaid over time, but are perpetuities (as in the case of stock), alternatively are very long-term loans (small d), then aggregate assets will grow faster. A case which corresponds to a small (or rather zero) d , is when debt is rolled over.

If $i = 0$, i.e. an economy with zero interest rate, Eq. 8 implies: "Assets won't grow regardless of savings rate level, since incoming cash flow consists only of repayments of old loans." Note also from Eq. 13 that a relative increase in the savings rate s has a greater impact on the accumulation rate than a similar relative increase in the interest rate i .

The above exponential path given by Eq. 10, and the above conditions for asset growth, are derived by neglecting the time delay, as already stated. The actual path will grow insignificantly slower. The conditions found for asset growth are therefore considered essentially correct.

The parameter s (or equivalently, \bar{s}) is a decision variable for the black hole. The initial assumption of a constant value here is unrealistic. It is more reasonable to assume that s will increase with increasing assets A_b for the typical agent: We are only considering that part of the income for the agent (black hole) that is financial, which generally comes on top of income from real economic activities. Such agents have few pressing material needs and thus s should increase with increasing assets. We will all the same, for simplicity of argument, assume s constant. One then has to keep in mind that this gives a *lower bound* for black hole asset growth. The more realistic assumption of increasing s with growing assets means accelerated asset/debt polarization, following Eq. 8.

We have by now made some definitions and assumptions, and drawn some conclusions concerning the dynamics of accumulation and money flows for a *single* agent. But our primary task is to examine the dynamics of *aggregate* net assets and flows in a society. This is more difficult. We tentatively assume that the above defined coefficients and entities may be

meaningful in an average, aggregated sense. And more specifically, we tentatively conclude from inequalities Eq. 11 - 13 that average high interest rates, slow rates of repayment or high savings rates, all are conducive to polarization for society as a whole.

Microeconomic black holes

What sort of agents in an economy may be categorized as "black holes"? We will now examine three main types of agents: Firms, households and banks.

Black hole firms

The behaviour of a well-to-do firm may be depicted through the guitar-like shape in Fig. 4.

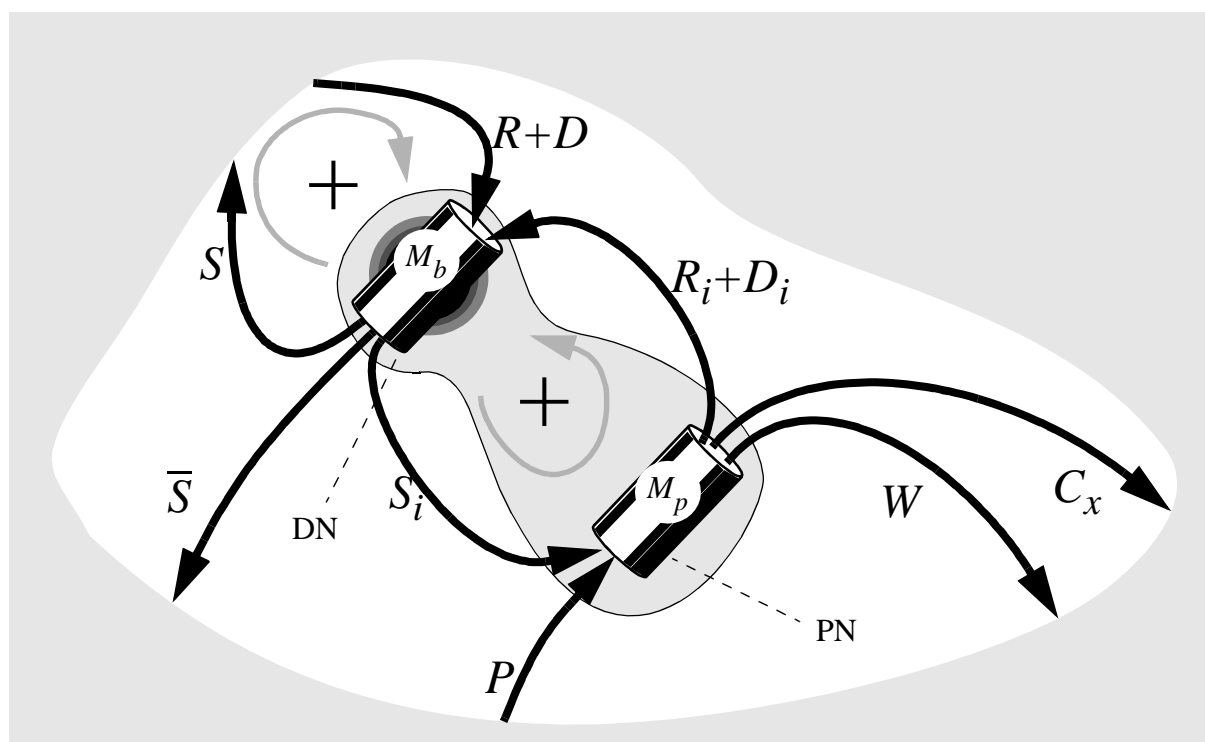

Figure 4. The black hole firm

The firm, which may be of any type except a bank, is modeled as consisting of a "decision node" (DN) which controls the firm's economy, and a "production node" (PN) delivering goods or services. The DN regards the PN as a source of profits which has to compete with external alternatives for the allocation of cash. We have

S, R, D = net cash flows associated with the firm's financial investments.

M_b, M_p = money stock at the decision and production node, respectively.

\bar{S} = cash flow which is not regarded by the DN as obliged to give future returns; paid

out for goods and employment directly benefitting the DN.

S_i = cash flow allocated to ("invested in") the PN by the DN; subscript "i" signifies "internal."

R_i = dividend drawn off from the PN by the DN.

D_i = depreciation, considered equivalent to asset reduction due to repayment of a financial asset.

C_x = cash flow for both capital and intermediate goods or services needed in production. Subscript x signifies "external."

W = wages for production personnel.

P = flow of received payments for delivered goods or services.

For convenience the firm is assumed to be an individual proprietorship; one agent, the DN, owns it. We will further on consider the more representative case of a corporation with stockholders. This will not make any important difference.

The model in Fig. 4 may be transformed by separating the DN and PN parts into two "agents." The result is shown in Fig. 5 (a).

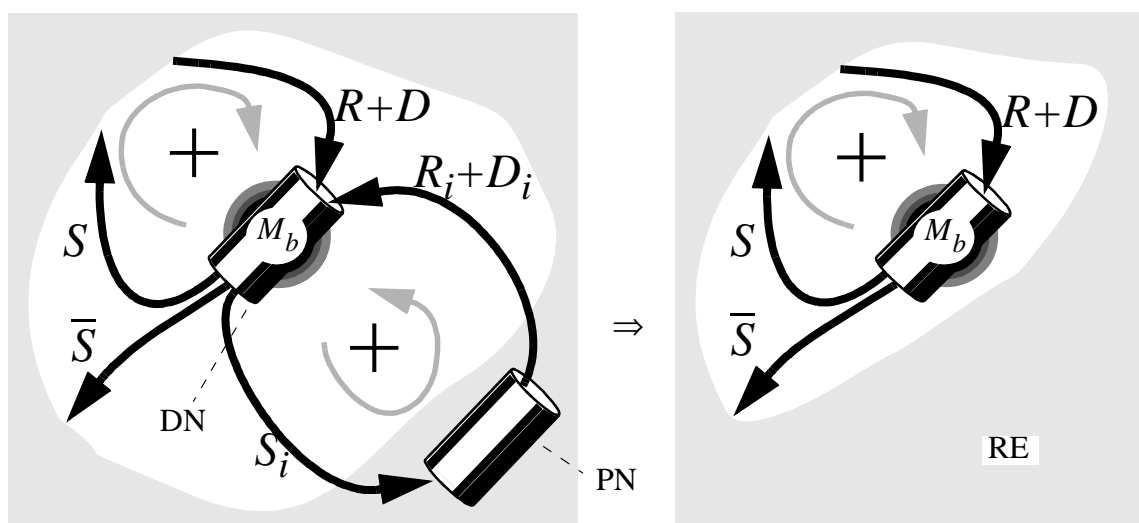

Figure 5 (a) and (b). Separating out the black hole

The PN node is now reckoned as part of the RE, and a black hole agent remains. In Fig. 5 (b), the terms S_i and $R_i + D_i$ have been incorporated into respectively S and $R + D$. Note that Fig. 5 (b) is similar to Fig. 2.

Now to the case of a less well-off firm (zero or positive net debt). This firm is represented as indicated in Fig. 6.

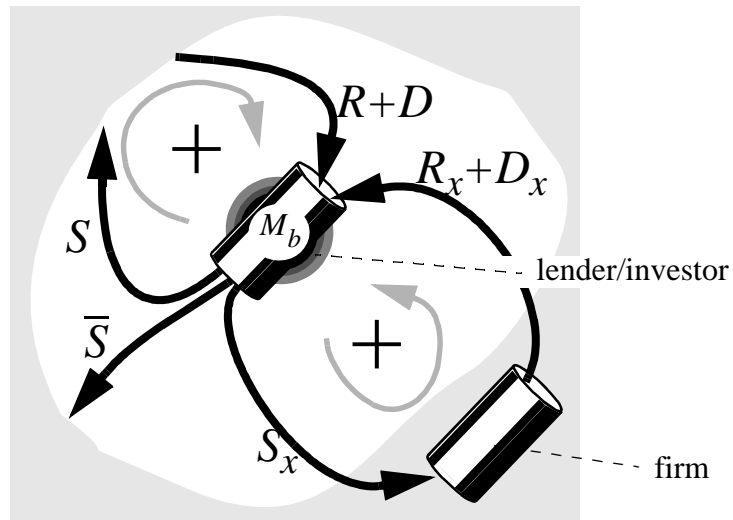

Figure 6. The indebted firm

Such a firm is more or less dependent upon bank loans, or stock bought by external investors. Note the similarity between the firm in Fig. 6 and the PN node in Fig. 5 (a). We have now fitted all sorts of firms, except banks, into the black hole framework.

Remarks on the terms "investment" and "saving"



There is no physical investment cash flow shown in the firm model in Fig. 4. We do not here distinguish between the firm's purchase of intermediate goods and services on one hand, and the purchase of capital goods ("investment") on the other. These cash flows are all lumped together under the label " C_x ." This is because both types of transaction have something important in common: Cash is paid out with no obligations on the recipient of future returns to be paid back.

In contrast to this use of the term "investment", it may be used as a synonym for "saving." "Investment" in conventional language then has two different meanings: the act of purchasing capital goods or services, as opposed to the transfer of liquid funds on the condition of receiving future dividends; i.e. financial investment, saving.

In many cases these are two aspects of the same operation, but not always. A case in point is a strong recession or a depression. Then (financial) "investment" in the second sense above, i.e. cash passing from agent to agent for purely pecuniary reasons, constitute a leakage of liquid funds which depresses the economy further, while increased investment in the first sense would be an injection stimulating the economy. The phenomenon of "Casino capitalism", observed during the 1980s and still going strong, is an example: A growing share of "investment" is in the second sense, in securities, in real estate etc., and one does not get a corresponding level of second phase activity generating purchases of goods or services and corresponding positive effects on employment.

To avoid confusion, we will from now on employ terms in the following manner:

- The transfer of cash on the condition of future receipt of dividends will be designated *allocation for returns*, abbreviated "AFR." This category encompasses several types of cash transfer, be it a deposit to a bank account, a purchase of stocks, bonds, etc., a speculative acquisition of real estate, or even a management decision in a firm to allocate funds intended for a subsequent purchase of capital goods or services.

- On the other hand, the actual transfer of cash to providers of capital goods or services will be labeled "investment" and, when there is no need to make a distinction, simply lumped together with other purchases, as in the case of C_x in Fig. 4.

Black hole households

The behaviour of a well-to-do household may be depicted as in Fig. 7.

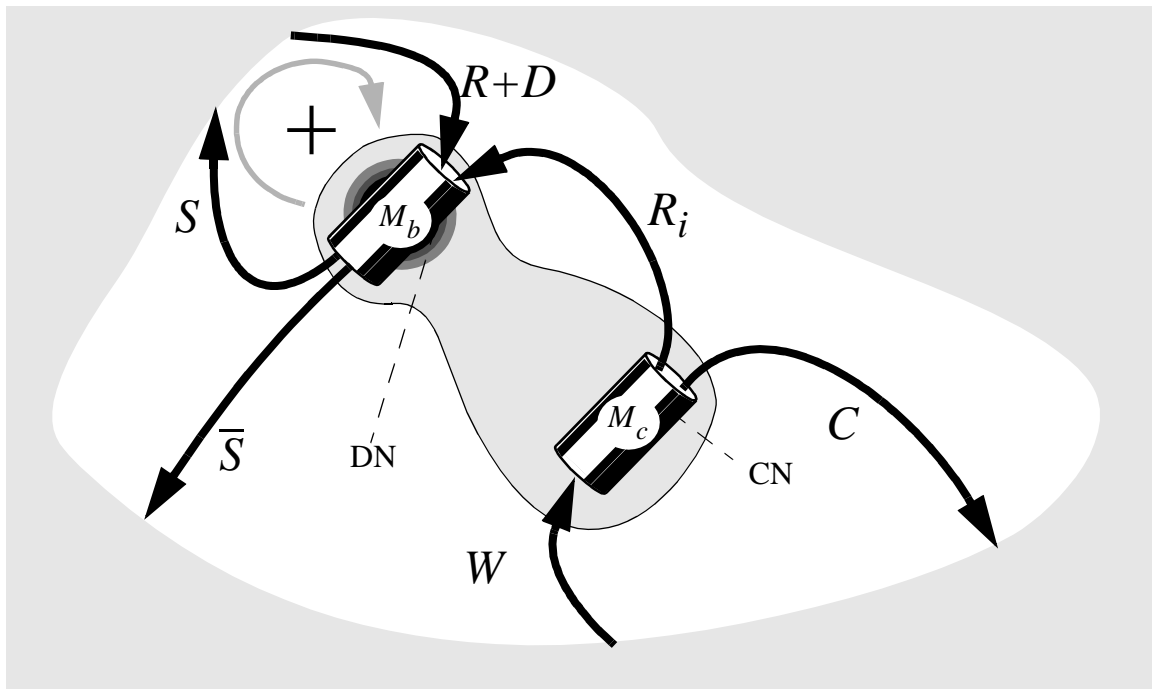

Figure 7. The black hole household

"CN" is an abbreviation for "consumption node", which represents the "non-financial part" of the household, using approximately the amount of wages coming in for consumption and other non-dividend-giving payments. We define:

\bar{S} = cash flow for wanted *extra* consumption, and for direct employment of personnel.

This flow is assumed to be proportional to the household's financial income

R_i = part of received wages which (possibly) is set aside for saving.

M_b, M_c = money stock at the decision and consumption node, respectively.

Note that there is now no positive feedback between the DN and the CN, in contrast to the firm model, where the feedback was due to the exploitative relationship between the DN and the PN. In the household case, there is no such relationship.

In analogy with the firm model, Fig. 7 indicates that for our purposes the household may be modeled as two separate units: A black hole unit, and a zero-asset (ignoring money stock M_c) consumption unit.

This is depicted in Fig. 8 (a) and (b). The consumption unit is considered part of the RE. In this case, S in Fig. 8 (b) is identical to S in 8 (a), and R_i have been incorporated into R .

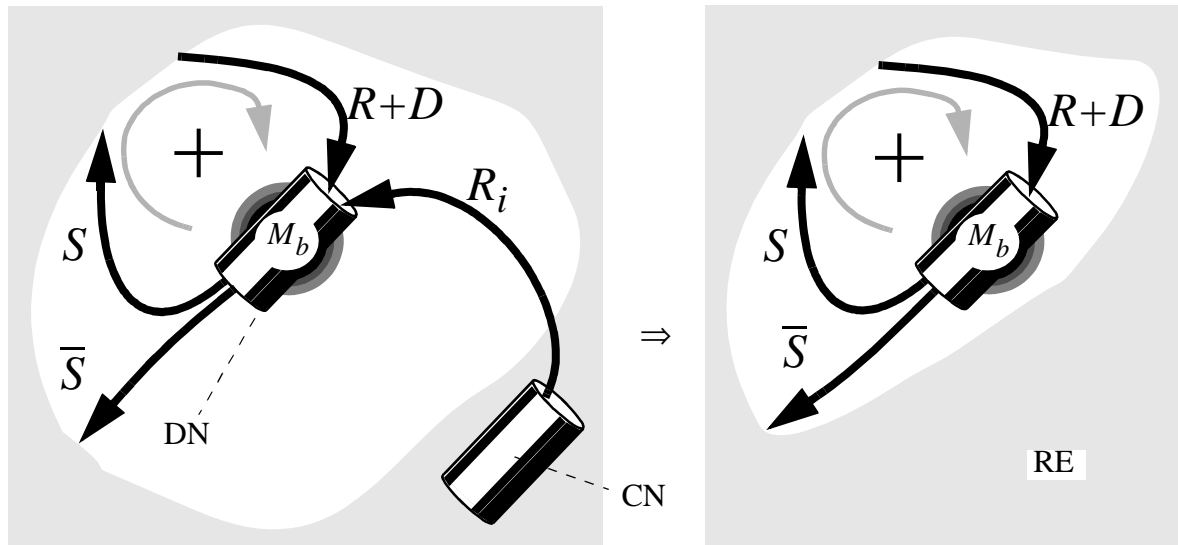

Figure 8 (a) and (b). Separating out the household black hole

In analogy with the model for a firm, we may now conclude that the set of households in a society may be modeled as: (a) a minority of agents behaving in accordance with the definition of black holes, (b) a corresponding number of zero-asset agents, which are the CN part of those under (a), (c) additional zero-asset agents, (d) a large number of debtor agents using part of their income for interest and repayments and the rest for consumption. Category (a) we include in the

set of black holes, and categories (b), (c) and (d) belong to the RE². We are thus able to fit all sorts of households into the black hole/RE framework.

Black hole banks

A bank could have been modeled the same way as a firm, with a decision node and a production node. But since the bank's "production" is exclusively the handling of cash flows, it may be represented simply as a slightly modified black hole, shown in Fig. 9.

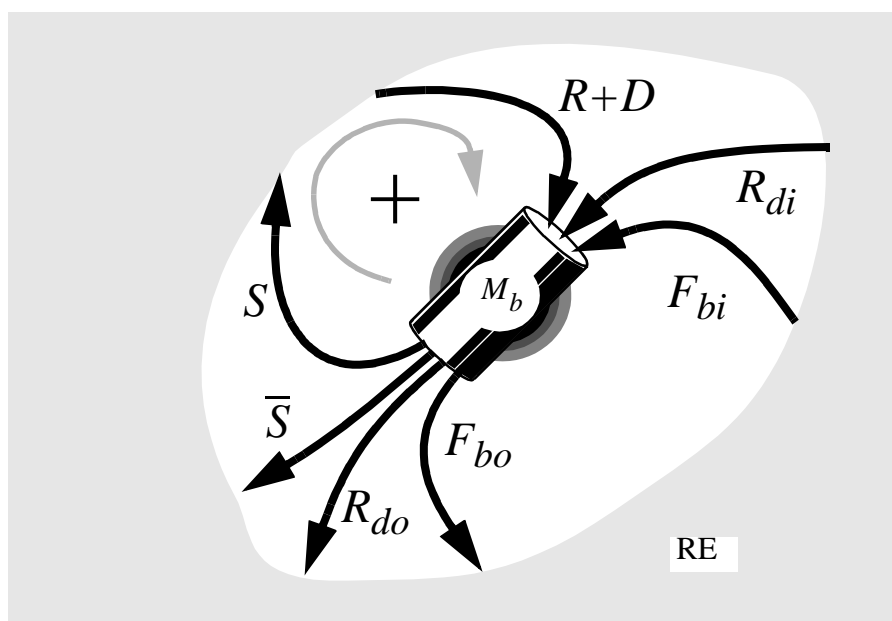

Figure 9. The black hole bank

The term "bank" in our context includes all types of firms which make their profits solely from financial activities. The flows F_{bi} and F_{bo} represent the bank's securities trading cash flows, and also flows related to other banking services. Wages are part of \bar{S} .

2. At this stage we may note that all the flows within the RE are *real* flows, in the sense that they represent either wages, or purchase of consumption or investment goods. Therefore the abbreviation "RE" (the rest of the economy) used until now, could just as well represent the term "real economy."

The flows in the upper left half of Fig. 9 is due to the bank's own net financial assets, as opposed to the flow R_{di} , which is interest stemming from the bank's loans out of deposited money. R_{do} is interest paid to depositors, $R_{do} < R_{di}$.

While deposits are in the care of a bank, they are still the property, i.e. part of money stock, of depositors. They are consequently not included in the money stock of the bank, M_b .

We assume that a constant share of total money stock³ M in society is in the form of bank deposits, and furthermore that a constant share of bank deposits is lent out at any time, i.e. a fractional reserve banking system. We ignore the share of deposits which is lent out to other black holes, and end up with a simple relation:

$$R_{di} = \alpha M, \quad \alpha < 1 \quad (14)$$

R_{di} is an interest burden on the RE that comes on top of the flow $R + D$.

The part of R_{do} paid to the agents in RE is considered so small that it may be ignored. We will also ignore the burden R_{di} in the following. This assumption will lead to a conservative estimate of asset growth.

Will black holes "evaporate"?

We have by now defined types of real agents which may be classified as black holes. But we have tacitly assumed that the population of units in a macroeconomy satisfying the black hole criterion, remains invariant: Existing black holes may grow at somewhat different rates, but they will remain in the category "black holes." This is unrealistic. There will at all times be units which, through losses, cross the border and become part of the RE. On the other hand, some units will, through luck or skill, leave the RE and achieve black hole status.

3. We assume for the time being that aggregate money stock is constant for the sake of developing the analysis. This assumption will be rescinded later on.

A reasonable assumption is that aggregate net asset reduction due to "evaporation" of small black holes will be more than compensated by the accumulation processes for large ones. Two reasons for this may be given: (a) Larger black holes will wield market and political power due to their size, thus enhancing their profit-making possibilities. (b) It is conservatively assumed that the propensity to save s for a given black hole is constant, regardless of the size of the net assets for the hole. But as already pointed out, the propensity to save increases with increasing assets for a representative black hole agent. Therefore asset growth should often be steeper than exponential for black holes that are already large.

Loans vs stock

Another note is appropriate at this stage: Internal returns or returns from stock on one hand, have been put on a par with returns from loans and bonds on the other: Financing a firm through equity has been considered similar to financing by loans. But returns from stock may be adjusted in response to the actual economy of a firm, and thus give a flexibility for the firm that loans don't offer. We are, however, considering the financial process in the very long run. On this time scale the difference may be ignored, since stock must in the long run yield returns at least on a par with bonds and loans. If that was not the case, black holes would convert their holdings from stock to government bonds or interest-bearing deposits.

An aggregated model

The impact of black hole dynamics may best be studied from a macroeconomic perspective. Therefore it is useful to construct an "equivalent" aggregate black hole for the entire macroeconomy, and study its effects. This will be attempted in this section.

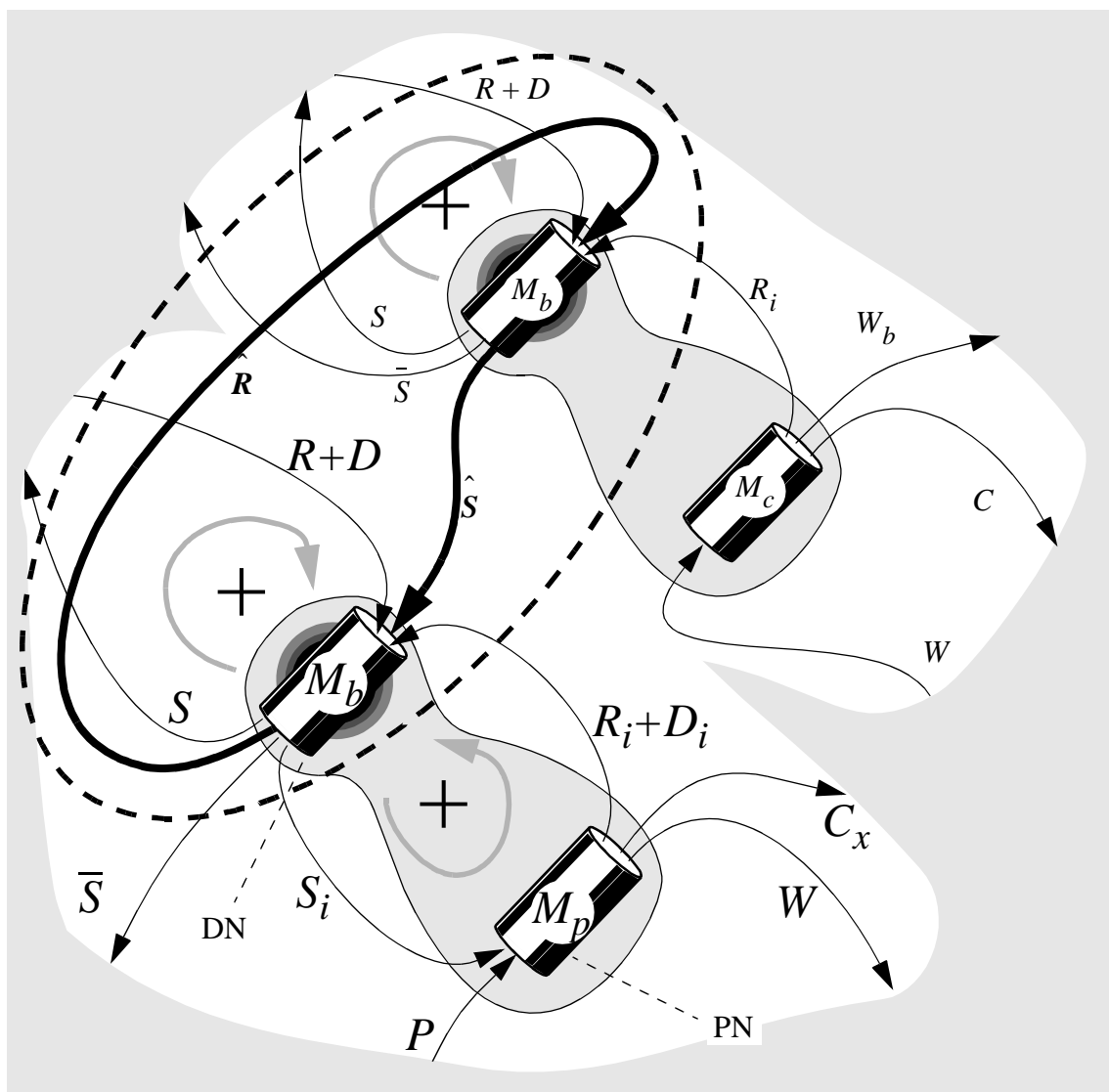

Figure 10. A black hole firm and one black hole stockholder

An approximately equivalent single macro black hole

(Microeconomic) black holes have transactions between them, not only with the RE. But we assume that even holes that are indebted to other holes have growing net assets because of their assets in the RE (if this was not the case the agent would not be a black hole per definition,

but instead be reckoned as a unit belonging to the RE). An example of a set of black holes and their interactions, is a corporation and its stockholders. This is illustrated in Fig. 10 (one household type stockholder only, for simplicity, in the upper part of the figure). Fig. 10 may be thought of as a combination of figures 4 and 7. Smaller size fonts are used to distinguish variables related to the stockholder from variables related to the corporation. Note that there is no element "D" in the cash flow to the stockholder. Furthermore: S and R for the firm are not *net* flows in this case, since the flows from and to the stockholder are separated out. The stockholder invests \hat{S} and receives \hat{R} from the firm (bold arrows). The decision node of the corporation is the management, which is considered to control the undistributed corporate profits⁴. By this we assume that the (successful) corporation accumulates funds even after returns to stockholders are subtracted, and the corporation remains a black hole along with the stockholders, even if it has to share profits with them. The aggregate of the stockholder and the corporation, indicated inside the dotted ellipse in Fig. 10, will have approximately the same effect upon the RE as a single black hole, even if the asset growth rates of the two agents may differ .

Similar arguments may be used to aggregate a set of more than two black holes into a single black hole model. After repeating this process several times, the final result will be a single approximately equivalent black hole for the entire society, interacting with the RE. The dynamics of this "macro black hole" may, following Eq. 8, be expressed as

$$\tilde{A}_b[t] = \tilde{A}_b[t_0]e^{\tilde{\lambda}(t-t_0)} \quad (15)$$

$A_b[t_0]$ is the total sum of net non-money financial assets for black holes versus the RE at time t_0 . Tilde (\sim) is used here to signify aggregate entities. (In subsequent sections however, tilde will

4. One may look at this another way, and assign all assets and the money stock of the corporation to the collective of stockholders. This does not make any important difference for our purposes.

not be used. We will from now on only consider a sole aggregated black hole for a given national economy.)

$\tilde{\lambda}$ is more difficult to specify. One cannot sum up exponential functions for black holes with different λ_n 's to an exactly equivalent aggregate expression of the type in Eq. 15.

But $\tilde{\lambda}$ may always be interpreted such that Eq. 15 is a first-order approximation of the aggregate asset growth that will take place in a fairly short future time interval. It may be shown that the choice that satisfies this criterion, is a weighted average over growth rates for all agents where the weight is proportional to the net financial assets of the agent in question:

$$\tilde{\lambda} = \frac{1}{A_b[t_0]} (A_{b1}[t_0]\lambda_1 + A_{b2}[t_0]\lambda_2 + \dots + A_{bn}[t_0]\lambda_n + \dots) \quad (16)$$

We do not, however, need Eq. 15 and Eq. 16 in the following. The purpose of the above was only to justify the concept of an aggregate net asset growth path.

Black hole sector money stock , dispersion and percolation

There are two important modifications that will be introduced at this stage. The first concerns the fuzziness of black hole response to input flows, i.e. a specific packet of money coming in, will be paid out again in a time-dispersed manner. This dispersion effect will be even more pronounced when a multitude of single agents with different mean time delays are aggregated into one "equivalent" macro agent.

A second modification is needed because one must somehow still account for the effect of flows *between* individual agents when one aggregates these into a more or less equivalent single agent. Such flows require a larger aggregate money stock for for instance the black hole sector (from now on abbreviated "BHS"), than what would have been necessary if the black holes had had no flows between them. They also mean a a larger processing time delay seen from the RE, because money coming into the BHS has to "percolate" via other agents in this sector before again being returned to the RE.

To develop our argument, we introduce the delta function $\delta[t]$. It has zero duration but infinite amplitude, such that it has unit area. It may be defined as the limit as $\Delta t \rightarrow 0$ of the function shown to the left in Fig. 11. It occurs at $t = 0$. In our context we may think of it as a unit "packet" of money (a "monetary unit impulse") that is received by a black hole during a single day (which is a very short time interval compared to the time scale of the dynamics we are considering). For the individual black hole we have until now assumed that the money flow is delayed exactly τ_b time units, resulting in the *impulse response* shown to the right in Fig. 11.

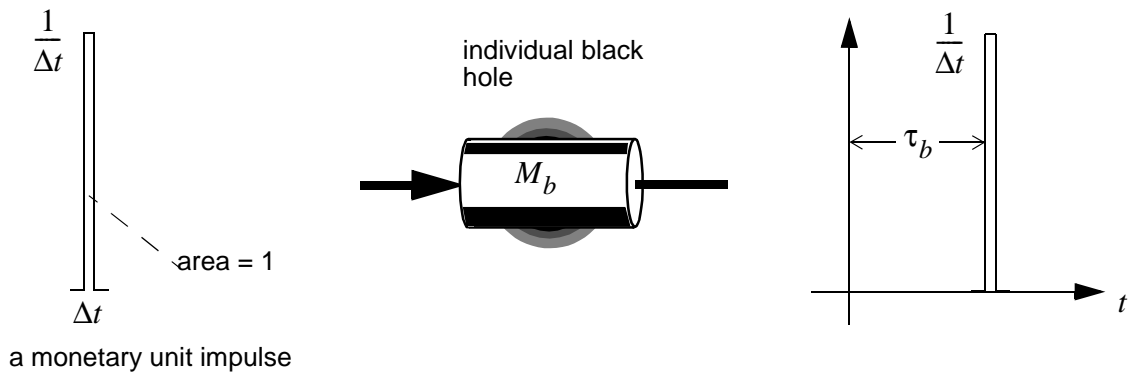

Figure 11. The time-delayed impulse response

A more realistic response is shown in Fig. 12. Now time dispersion is introduced through an exponentially decaying impulse response.

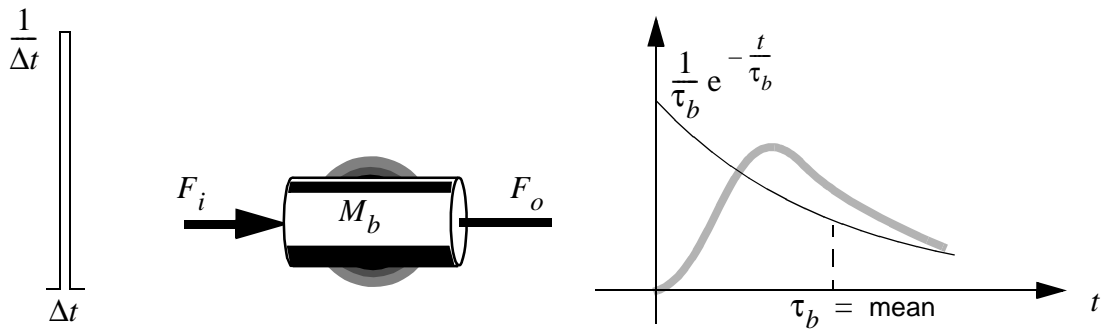

Figure 12. The time-lagged impulse response

The term τ_b is now a "mean" delay time characteristic for this response (more precisely, τ_b should not be called a time delay any more, but a *time lag*). This response also satisfies the necessary conditions of (a) unit area (i.e. the flow of money going out, integrated over time, is equal to the amount that went in), (b) no money emerging before it is injected (causality), and (c) the response being ≥ 0 for all t . Another response satisfying the above conditions is also suggested in Fig. 12 (there is an infinity of them). We have somewhat arbitrarily chosen the simplest of them, the decaying exponential function. The choice is not critical for the analysis to follow.

We now consider the aggregate black hole, which consists of all individual black holes. We initially (and unrealistically) assume that they have no flows between them. We assume that the "exponential decay" in Fig. 12 is also representative for the aggregated case, with τ_b some sort of weighed mean of time constants (time lags) for all individual responses. We will now show that the function chosen incorporates a meaningful solution for money stock of the aggregate black hole. We define, as suggested in Fig. 12, and in accordance with equation Eq. 3:

$$F_i = R + D = \text{cash flow from the RE (in)to the aggregate black hole.}$$

$$F_o = S + \bar{S} = \text{total cash flow out of the BHS and back to the RE.}$$

For BHS money stock we must have

$$\dot{M}_b[t] = -F_o[t] + F_i[t] \quad (17)$$

We now try the relation

$$F_o[t] = \frac{1}{\tau_b} M_b[t] \quad (18)$$

and substitute Eq. 18 into Eq. 17. We get

$$\dot{M}_b[t] = -\frac{1}{\tau_b} M_b[t] + F_i[t] \quad (19)$$

which, together with Eq. 18, give the impulse response specified in Fig. 12, while also satisfying the money stock balance Eq. 17.

By now we are able to sketch a new block diagram for the aggregate system, where the dispersion effect is accounted for. Eq. 18 - Eq. 19 are equivalent to the first-order subsystem in the shaded region in Fig. 13. If we compare this to Fig. 3, we see that the time delay is now exchanged for this more realistic subsystem.

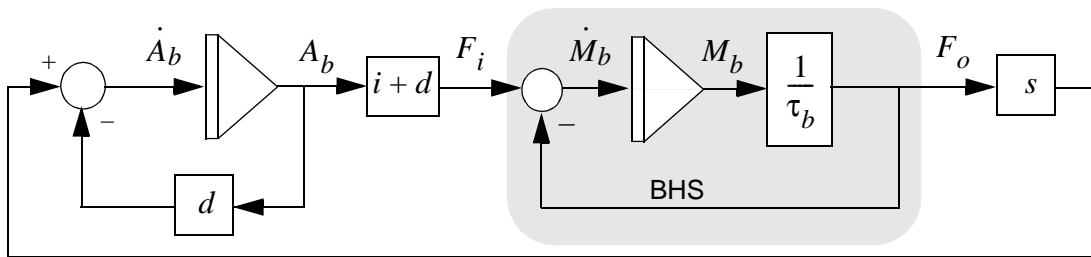

Figure 13. Financial accumulation with a time lag

The model in Fig. 13 does not, however, account for the "percolation" effect, so it must be modified further, see Fig. 14.

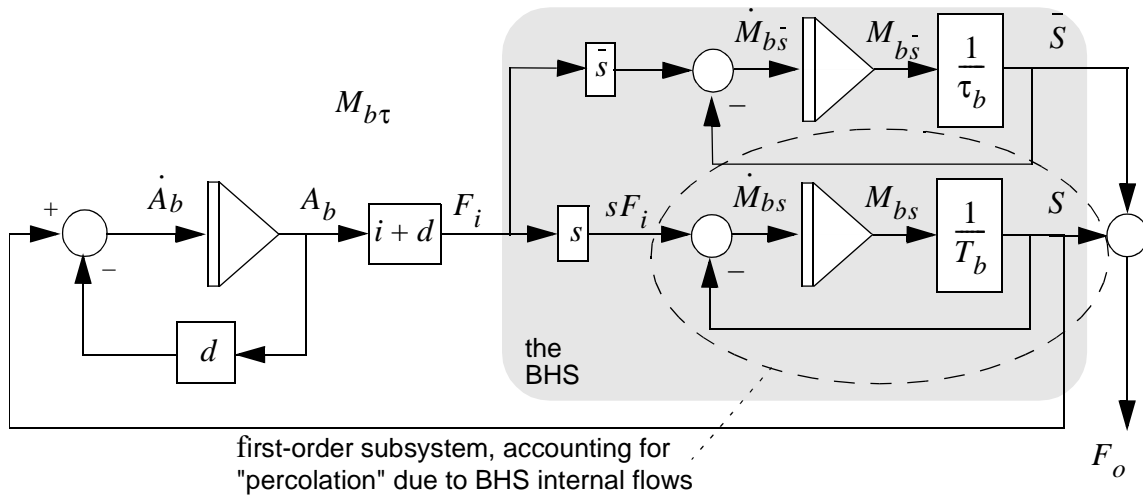

Figure 14. Financial accumulation with separate time lags for non-saving and saving

We have now divided the incoming cash flow to the aggregate black hole into one upper flow which we may interpret as allocated for consumption, and a lower one for AFR.

Note that S and \bar{S} are modified compared to the original definition, Eq. 5: S and \bar{S} now equal the outputs from respectively the lower and upper first-order subsystem. Also note that total BHS money stock is now given by

$$M_b = M_{b\bar{s}} + M_{bs} \quad (20)$$

The splitting of flows is done to allow for different time lags, $T_b \geq \tau_b$, in the two branches. (In the special case $T_b = \tau_b$, Fig. 14 is equivalent to Fig. 13). Consider the upper branch first.

Money arriving at a black hole which later is used for consumption, will per definition be returned directly to the RE and not to any other black hole. So the time lag must still be τ_b for this branch.

For the lower "savings branch" however, the situation is more complicated. We assume that at a given stage in the polarization process, any (in an average sense) individual black hole's outgoing savings cash flow is divided into fractions ρ (back to the RE) and $(1 - \rho)$ (to other black holes), where $0 < \rho < 1$. This is illustrated in Fig. 15. It may be shown (using either the Laplace transformation, or adding up an infinite number of impulse responses) that this results in the lower branch in Fig. 14 *also* being a first-order system, with

$$T_b = \tau_b / \rho \quad (21)$$

The interpretation of the parameter ρ is the following: In the limit case $\rho = 1$, we have $T_b = \tau_b$. This means that AFR ("savings") money in the BHS will only be lagged by τ_b before being returned to the RE again, without "taking detours" via other black holes. At the other extreme, when ρ is close to zero, the RE will have to wait very long before money intended for AFR purposes emerges from the BHS: The average black hole prefers transactions with other holes instead of channeling cash back to the RE. We have slow "percolation." This fits well with Eq. 21, since a small ρ implies a large time lag T_b .

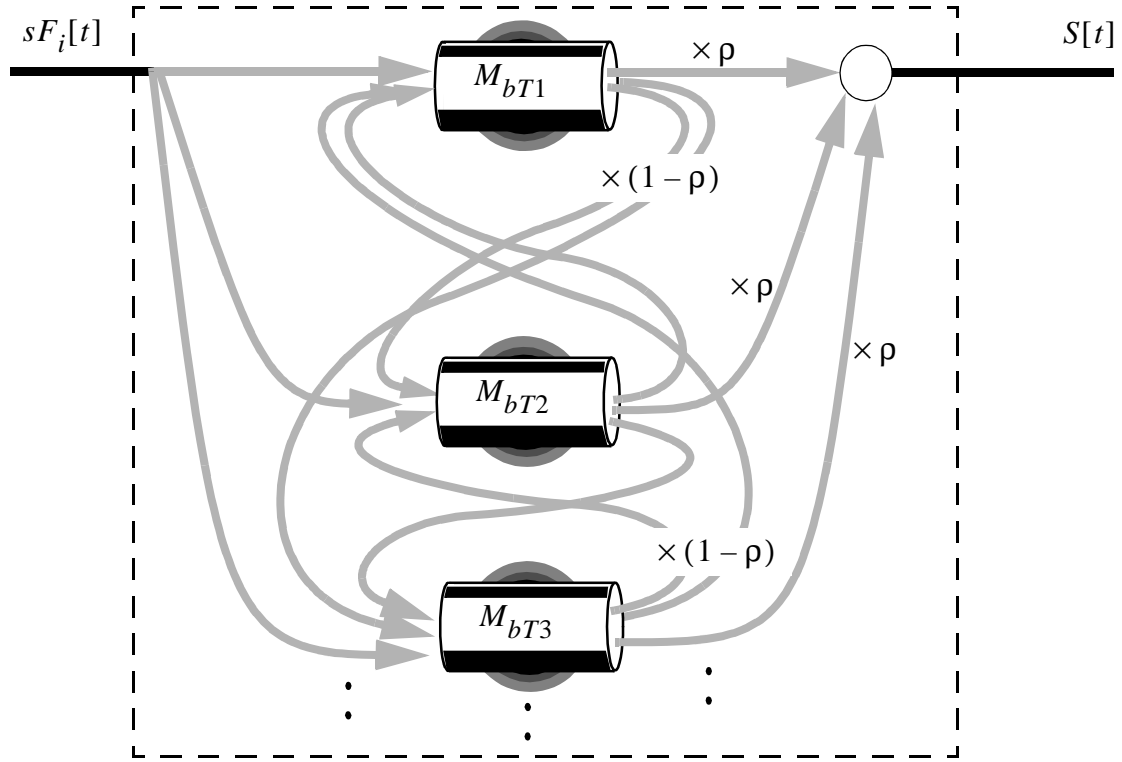

Figure 15. Cash circulation in the BHS

Modeling the RE (the debtor sector)

We are now going to include the RE in the model. We may use the same reasoning on the effects of aggregating all agents in the RE as we used for the black holes, since RE agents will pass money to each other (*such circulation of money within the RE is indeed the whole purpose of a monetary system*, at least seen from an anti-speculation position!), not only back to the BHS. This will lead to a first order differential equation describing the percolation and the money stock for the RE, similar to that of the BHS. Equations for the RE are then

$$\dot{M}_r = -F_i + F_o \quad (22)$$

$$\dot{M}_r = -\frac{1}{T_r} M_r + F_o \quad (23)$$

There is a crucial difference, however: While a BHS agent *has a choice* whether to send money back to the RE (for AFR or for consumption) or to use it for AFR inside the BHS, the RE must

yield to debt service demands from the BHS. It may only circulate cash within the RE to the degree BHS requirements are satisfied first.

Furthermore, the RE will willingly accept new loans offered by the BHS, since reluctance to acquire debt will only become widespread when serious crisis sets in and insolvencies are very common. A long pre-crisis growth phase where impressions of the last deep recession or depression fade as years go by, is conducive to an increasingly bold attitude from both potential lenders and debtors. This growing recklessness is characteristic of what Hyman Minsky calls "the euphoric economy" (Minsky, 1986).

Also, lenders will consider the sort of collateral being offered. If this seems satisfactory, loans will be given. When real estate and other collateral values are deflated during a later crisis, they of course are in for a surprise. But this is easily ignored for the time being.

Concerning potential debtors (RE agents), they are willing to risk heavier debt loads, believing (or if at a later stage in the process - simply hoping) that they will be able to service it. And RE agents have little choice: If they are low on cash, which they will (in an average sense) be to an increasing degree as polarization proceeds, they simply *have* to borrow.

We then have a situation where both the flow *to* the RE (F_o) and *from* the RE (F_i) are, in an aggregate sense, beyond the RE's control. Then money stock in the RE may simply be considered to be the integrated net cash flow to the RE, ref. Eq. 22. Since F_i is not controlled by the RE, T_r will now be a *dependent* variable, having to adjust with time so that

$$T_r = \frac{1}{F_i} M_r \quad (24)$$

is satisfied.

Based on the above , we are now able to extend our block diagram as shown in Fig. 16.

Note that the two thick shaded arrows signify the actual direction of cash flows, which should not be confused with the interpretation of the thin arrows in the block diagram. Note also the use of thick lining round the block in the lower right, signifying a non-linear relationship, Eq. 24.

Also note that we have used Eq. 21 to substitute for $1/T_b$ in Fig. 16.

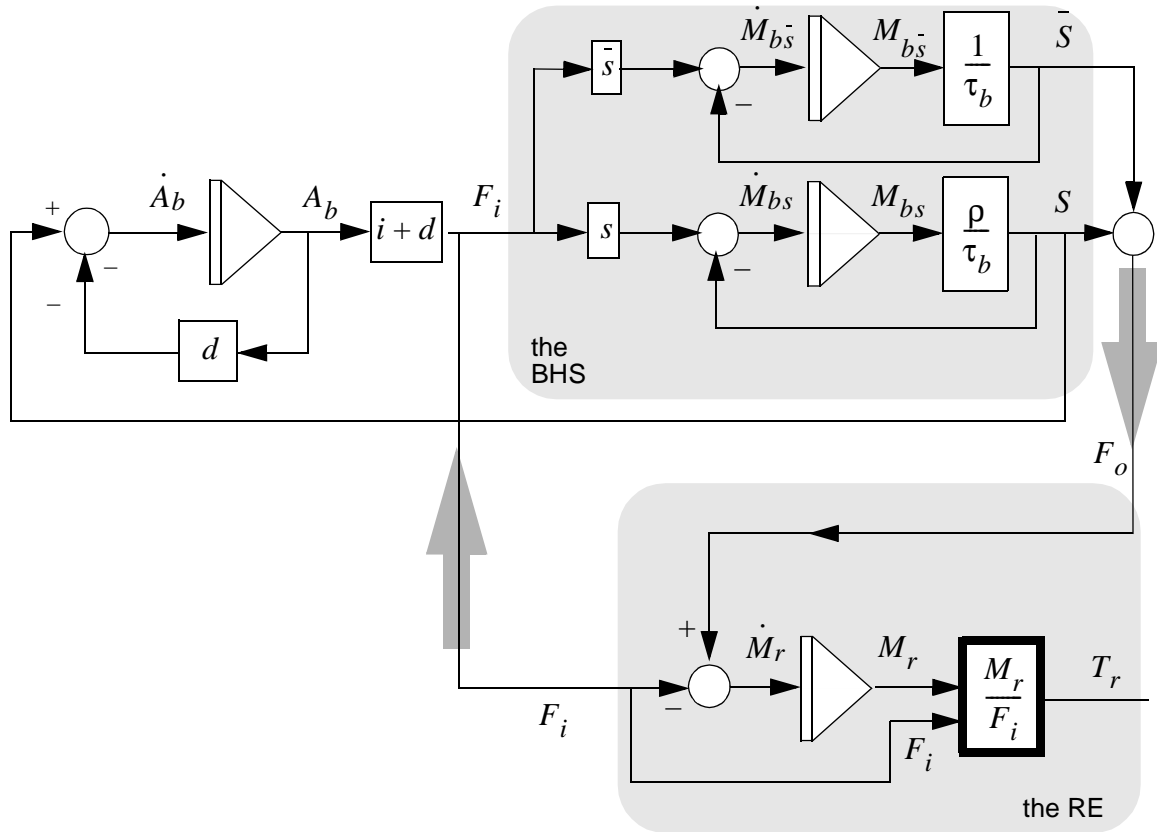

Figure 16. BHS connected to the RE.

Accounting for increasing economic fragility

Until now we have assumed that asset reduction effects of losses and insolvencies are negligible. Clearly this cannot hold in all situations. From Eq. 24 we see that a small T_r means high indebtedness (remember, F_i is the mandatory flow to the BHS due to debt service obligations) and corresponding scarcity of cash for transaction of real economic activity.

We thus consider the time parameter T_r to give a meaningful and concentrated measure of RE "economic fragility." Since a small T_r means high fragility, we will from now on use the term *inverse fragility* for T_r . Since this fragility is caused by indebtedness, it resembles the financial fragility concept of Minsky (Minsky, 1986). He attributes fragility to increasing debt-related interdependence between agents.

From the discussion leading to Eq. 21, we know that a small time lag T means that a significant share of money flowing *to* a sector is released from the average agent *out of* the sector without first being used for transactions *within* the sector. Applying this to the RE sector, we postulate a negative feedback from T_r to the asset growth process, accounting for losses due to increasing fragility, following a formula

$$b = \alpha \rho_r = \alpha \frac{\tau_{r0}}{T_r} \quad (25)$$

The transition from the middle to the rightmost term follows from Eq. 21. We have

b = loss rate; accounting for asset reduction due to losses or insolvencies
[% / time unit]

α = a suitably chosen coefficient; $\alpha > 0$.

τ_{r0} = a lower limit for T_r .

If T_r decreases towards τ_{r0} , real economic activity is increasingly crowded out by debt service requirements and this leads to increased losses. When $T_r = \tau_{r0}$, all cash from an RE agent goes to service debt, and no cash is left to flow between RE agents. Eq. 25 may also be explained by considering the middle term, containing the factor ρ_r . Following the discussion leading to Eq. 21, ρ_r is the money flow share from the average RE agent to the BHS, as opposed to the share $1 - \rho_r$ which remains for (real-economic) transactions with other RE agents⁵.

5. More complicated formulas than Eq. 25 have been tried out. One example is $b = \frac{\mu}{1 - \beta \rho_r} = \mu \frac{T_r}{T_r - \beta \tau_{r0}}$, with $\mu > 0$, and $\beta > 1$. But results do not differ significantly, so Eq. 25 is considered sufficient.

We now assume that the behaviour of the BHS agents is influenced by the loss rate b . With greater losses, black holes will be more reluctant to part with their money, both for AFR and consumption, i.e. greater liquidity preference. And this tendency is reinforced by potential borrowers hesitating to go into debt. The effects of this are accounted for as shown in the modified block diagram in Fig. 17.

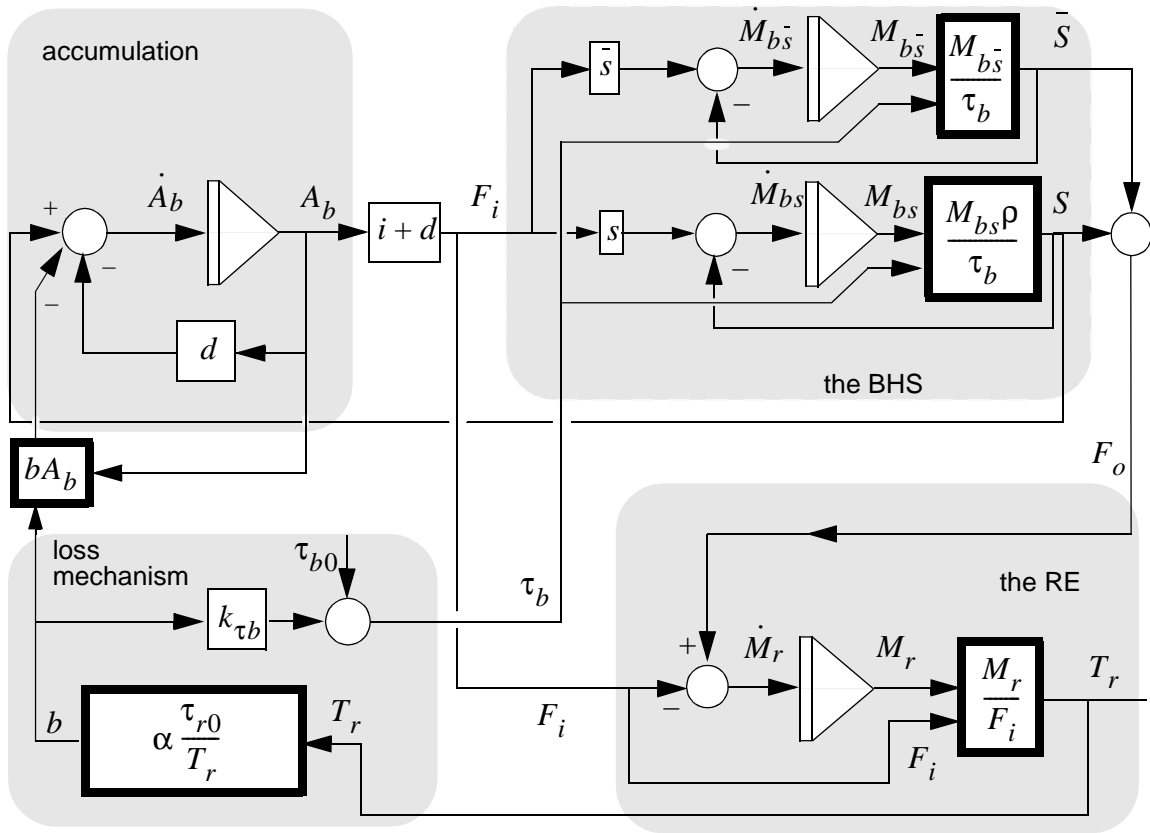

Figure 17. System with loss mechanism

Increasing liquidity preference means that τ_b grows. We assume

$$\tau_b = k_{\tau b} b + \tau_{b0} \quad (26)$$

Here $k_{\tau b}$ is a suitably chosen coefficient > 0 . τ_{b0} is a lower bound for τ_b such that $\tau_b = \tau_{b0}$ corresponds to a situation with maximum willingness from the BHS to spend money in the RE (minimum liquidity preference), and no cash flows whatsoever *between* black holes.

Investing where cash is most abundant

The coefficient ρ expresses the degree to which the black holes prefer to financially invest in each other, instead of in the RE. A small ρ means that the black holes have largely given up on the RE as an attractive target for AFR.

We have assumed ρ to be constant until now. A more realistic assumption is that *it will decrease with the relative share of total money stock in the RE*: As money to an increasing degree is found in the BHS and not in the RE, the black holes will "chase each other" for this money. This is in accord with the explosive growth of financial sectors worldwide observed since the early eighties. The simplest way to account for this phenomenon in our model, is to introduce the relation

$$\rho = \frac{M_r}{M_r + M_{bs} + M_{bs}^-}, \text{ which also satisfies } 0 < \rho < 1 \quad (27)$$

This leads to a new block diagram - Fig. 18.

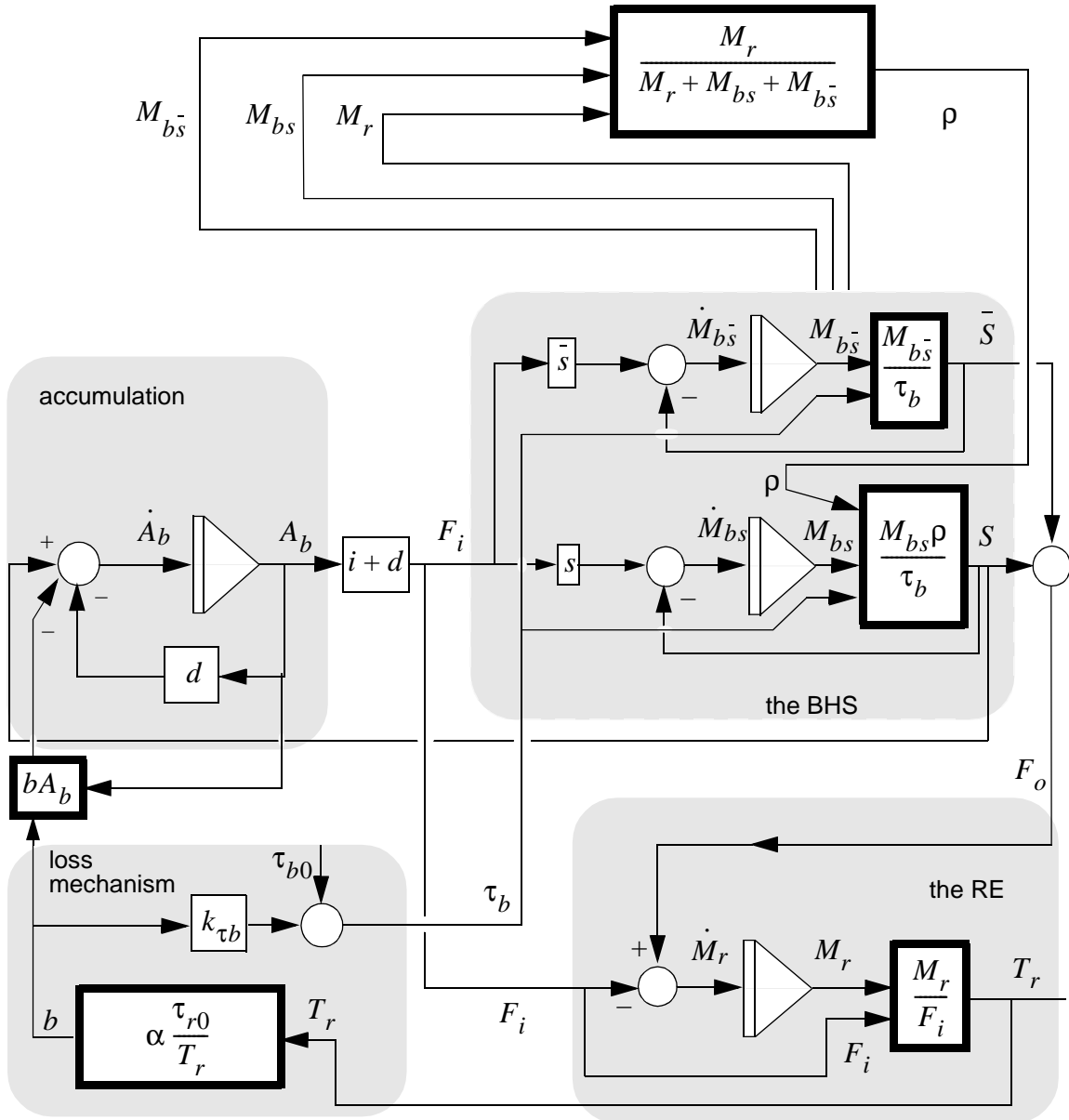

Figure 18. System with mechanism for attracting cash to the BHS.

Accounting for money growth

We have until now assumed that money stock is constant. This is clearly unrealistic. A further modification of our model is therefore to incorporate the effect of money growth. Banks create money when lending. According to the "Post-Keynesian" view (Lavoie, 1992), the Central Bank has to accommodate banks to uphold their liquidity⁶. We assume that the banks' share of the flow sF_i is constant, and that the flow of newly created money is again a constant

share of the lending flow from the banks: These assumptions lead to an approximate exponential growth of aggregate money stock, which is in accordance with what is observed in real life.

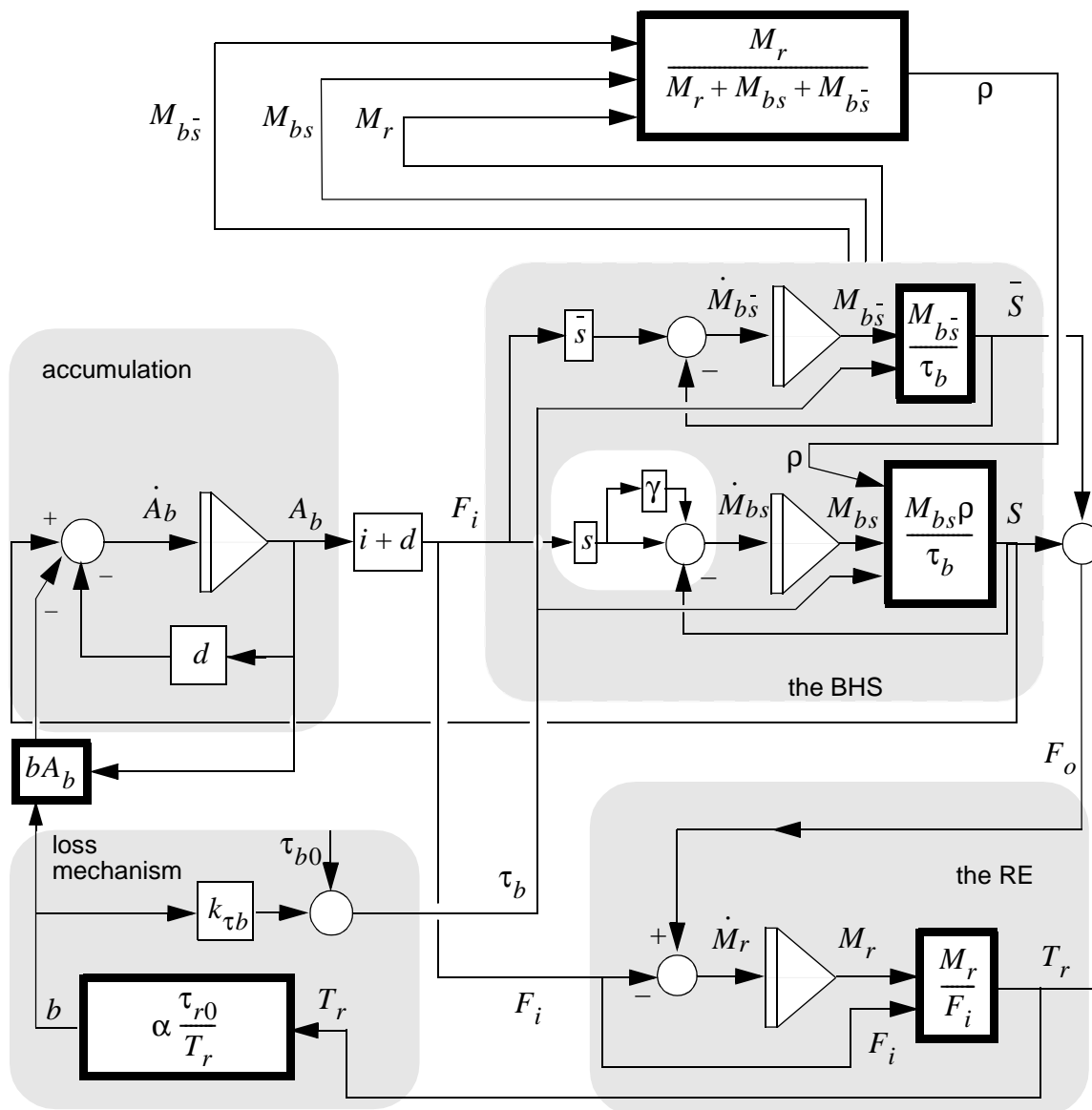

Figure 19. System with money growth mechanism.

We define a (small) *money growth factor* $\gamma > 0$, as indicated in Fig. 19. We see that the flow sF_i is then modified to $s(1 + \gamma)F_i$, where the term $s\gamma F_i$ is the flow of freshly created money.

-
6. But this point of departure is not necessary: any money growth explanation where newly created money is introduced as (bank) *loans*, suffices for our purposes.

Simulation and further analysis

We start with a note of caution: Since the system to be simulated is nonlinear, the principles of superposition and of property invariance under scaling do not apply. Such a system may display qualitatively very different behavior for small changes of system parameters and initial conditions. Furthermore, the more complex (because of the wish to increase realism) the model is made, the stronger is the danger of getting widely varying system behavior. When one also considers the fact that some of the numerical values in the model must necessarily be assumed somewhat arbitrarily (what is a reasonable "aggregate interest rate?"-savings rate? - what are reasonable initial values?), then there is a clear danger of ending up with a confusing array of qualitatively very different results, with correspondingly reduced value.

Because of this, we will in this paper consider a very crude model which may, just because of its simplicity, enable us to identify some qualitative results that should be valid also for more complicated and realistic models. We will start with the model corresponding to Fig. 18, i.e. fixed interest and savings rates, and the admittedly unrealistic assumption of no money growth.

We now have to assign some "reasonable" figures, both for initial values, and for parameters. We choose $i = 7\%$, $s = 0,7$, $d = 4\%$. The rate of repayment, d , is chosen based on a composite of short-term loans on one hand, and rolled-over debt and stock on the other.

Referring to Fig. 18, we also have to choose numerical values in the two relations in the loss mechanism part of the figure. These relations were introduced through Eq. 25 and Eq. 26. We choose $\tau_{r0} = 0,03$. This term corresponds to the mean time lag for individual agents in the RE: Any amount received will in the mean stay with the agent $0,03$ years $\cong 1.5$ weeks. This figure is arbitrary, but it should at least be of this magnitude; different values have been tested out, and the choice was observed not to be critical for simulation results. We also have to choose the coefficient α . A value $\alpha = 0,3$ has been found indirectly through several simulations, in a trial-and-error process. We will return to this further below. The next choice is numerical values

for Eq. 26. We choose $\tau_{b0} = 0,1$, which implies that the average black hole's base liquidity preference is assumed higher than that of the RE agent (again: the precise choice is not critical). When crisis is full-blown, defined by the (somewhat arbitrary) criterion $b = 0.1$, we assume that $\tau_b = k_{\tau b} b + \tau_{b0}$ has increased to 0.55, i.e. a bit over half a year. This gives $k_{\tau b} = 4,5$.

Finally, we need initial values for the four state variables of the system. Reasonable initial values have been decided through the criterion that society shall definitely not be indebted (polarized) at the start of the simulation path. This is satisfied for the choice $A_b = 5$ and $M_r = 1$, which gives an initial value of $T_r \approx 1,8$, $\Rightarrow \rho_r = 0,03/1,8 = 0,017$, i.e. an initial negligible debt service burden on the RE.

We choose $M_{bs} = M_{bs}^- = 0,03$. As long as we choose these two initial values that small, the values are not critical, because M_{bs} and M_{bs}^- will be automatically adjusted up to correct levels during the first few years of the simulation path (this is due to the small time lags associated with M_{bs} and M_{bs}^-). The simulation results are shown in Fig. 20.

We observe that assets grow exponentially, but at the end growth is more than cancelled by losses. Note the steadily decreasing inverse fragility T_r , which follows from the RE being both depleted of its money stock and at the same time having to service an increasing debt burden. This again leads to increasing losses, which at a certain stage, because of sharply increased liquidity preference in the BHS, block further money injection into the RE. This is what precipitates the dramatic turn for the worse at the end. For this choice of parameters, our generic economy experiences an acute crisis at $t \cong 43$ years. Note also the fall in the factor ρ , which indicates how the financial sector expands relatively, and strongly in the final stage.

We may now justify the choice $\alpha = 0,3$, which decides the magnitude of the loss rate. We observe that the loss rate b is below 1% at the start of the path, and increases steadily towards 3-4% before collapse occurs. This is considered reasonable.

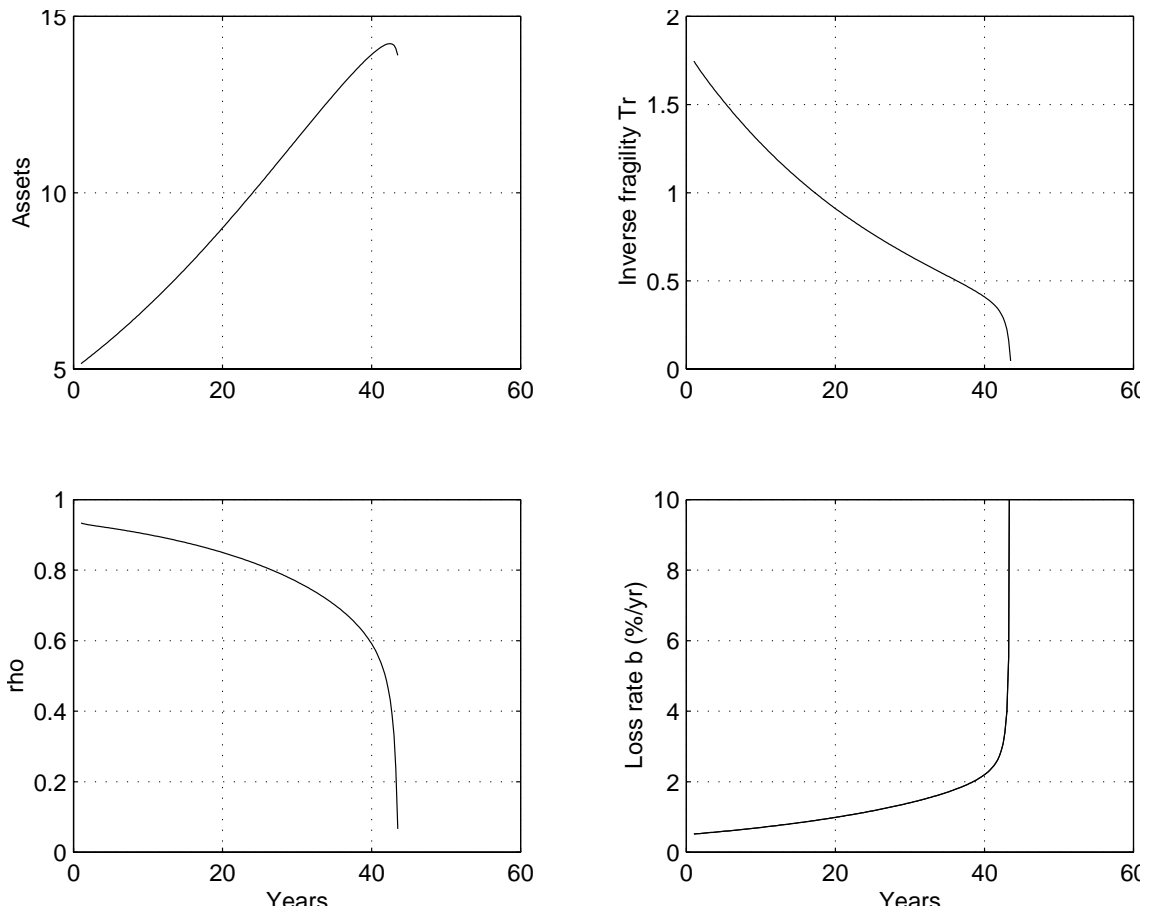

Figure 20. Simulation results when we have no money growth.

We will now introduce money growth, as defined in the model in Fig. 19, and try six different "money growth factors" $\gamma = 0, 0,01, 0,015, 0,02, 0,05, 0,1$. The results are given in Fig. 21. One set of curves corresponds to the zero growth case already shown in Fig. 20 (but note the change in time scale). For $\gamma = 0,01, 0,015$ we also end up in collapse, but it occurs later with increasing γ . For γ somewhat larger than 0.015, there is a bifurcation; we get qualitatively different system behaviour. There is no collapse. Instead inverse fragility, financial sector "size" $1 - \rho$, and loss rate b , stabilize. And M_r and A_b grow exponentially at identical rates.

We observe that a money growth rate (dotted curves in the lower right plot, note that this rate is varying with time, and must be distinguished from the "money growth factor" γ) above a certain level, is sufficient for avoiding polarization-induced collapse⁷.

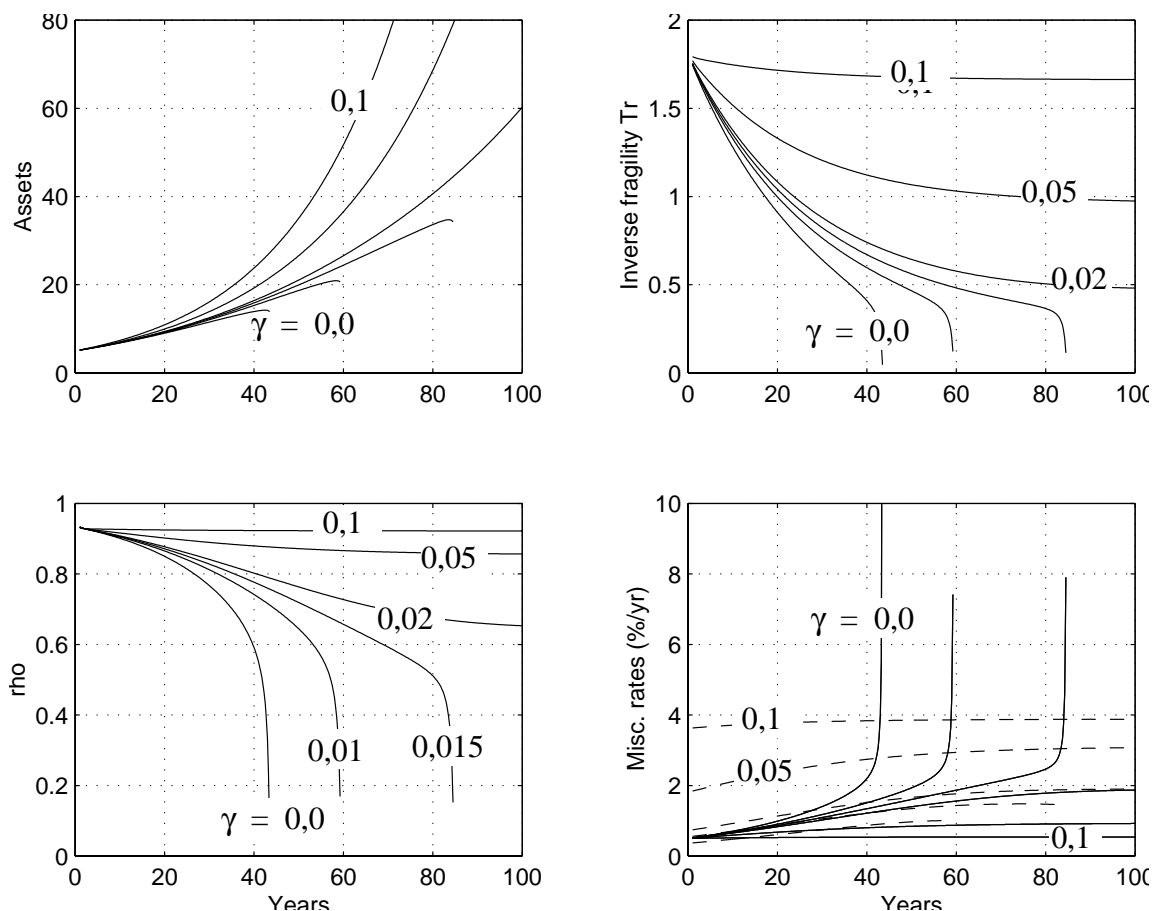

Figure 21. Simulation results with different rates of money growth.

For the border case $\gamma = 0,02$ collapse is avoided, but the end result is not good: Low inverse (i.e. high) fragility, a large financial sector, and a fairly high loss rate. Above this level, however, the simulations indicate a money growth window where collapse does not occur. For $\gamma = 0,1$ we observe that corresponding yearly money growth stabilizes at 4 per cent, which is low compared to historical money growth rates for representative OECD countries of 8 to 14 % (Dornbusch and Fischer, 1994). This, as an isolated observation, should indicate that world

7. This contradicts my statement in (Andresen, 1996), p. 106, where the collapse scenario was argued to be probable even with fairly strong money growth. This discrepancy is due to a less sophisticated model in that article: Instead of money being lagged *and then emerging from the BHS back to the RE*, a fixed share of incoming money flow was erroneously considered to be hoarded permanently at the BHS. This gave a too pessimistic picture.

economies are safe from polarization-induced collapse, except for the fact that *other* symptoms are present: bloated and growing financial sectors, and increased debt service flows relative to non-financial flows. Note that any scenario where M_r grows at the same rate as A_b , is *not* a polarization scenario. This holds whether asset and money growth is accompanied by inflation (due to too low real output growth) or not (because of sufficient real growth). Therefore, *if clear symptoms of polarization are observed in the real world, this means that M_r growth lags behind, which should be taken as a serious danger signal indicating that collapse is a distinct future possibility.* The only other possibility with such symptoms (assuming that the model is valid) corresponds to a path like in the case for $\gamma = 0,02$, where polarization occurs during a first phase, and then T_r flattens out because M_r growth rate has attained the same level as that of aggregate assets A_b . Such an economy may, however, diverge from this stable state of affairs at any later time and head towards collapse, if certain parameters change for the worse (or are changed due to policy decisions, for instance contractionary measures "to fight inflation", see also comments in the next section).

We will now try to establish how different parameters influence the bifurcation. We will examine a differential equation for T_r , since the objective is to avoid $\dot{T}_r < 0$. We have

$$\dot{T}_r = \frac{d\left(\frac{M_r}{F_i}\right)}{dt} = \frac{F_i \dot{M}_r - M_r \dot{F}_i}{F_i^2} \quad (28)$$

Substituting $\dot{M}_r = F_o - F_i$, $T_r = M_r/F_i$, and $\dot{F}_i = (i + d)\dot{A}_b$, we get

$$\dot{T}_r = \frac{F_o}{F_i} - 1 - T_r \left(\frac{\dot{A}_b}{A_b} \right) \quad (29)$$

As expected, we see that $F_o > F_i$ is a necessary prerequisite for avoiding collapse; more money must be injected into the RE than extracted from it.

We will now consider the cases corresponding to the paths for $\gamma = 0,02, 0,05, 0,1$, where T_r , ρ and b tend asymptotically to constant values. This again implies that A_b tends towards

pure exponential growth, as do the three other system states $M_{bs}, M_{b\bar{s}}$ and M_r . We consider the situation for "large" values of t . We may then write

$$A_b(t) = ae^{\lambda t} \quad (30)$$

Here a, λ are unknown constants. Consider part of the model in Fig. 19, see Fig. 22.

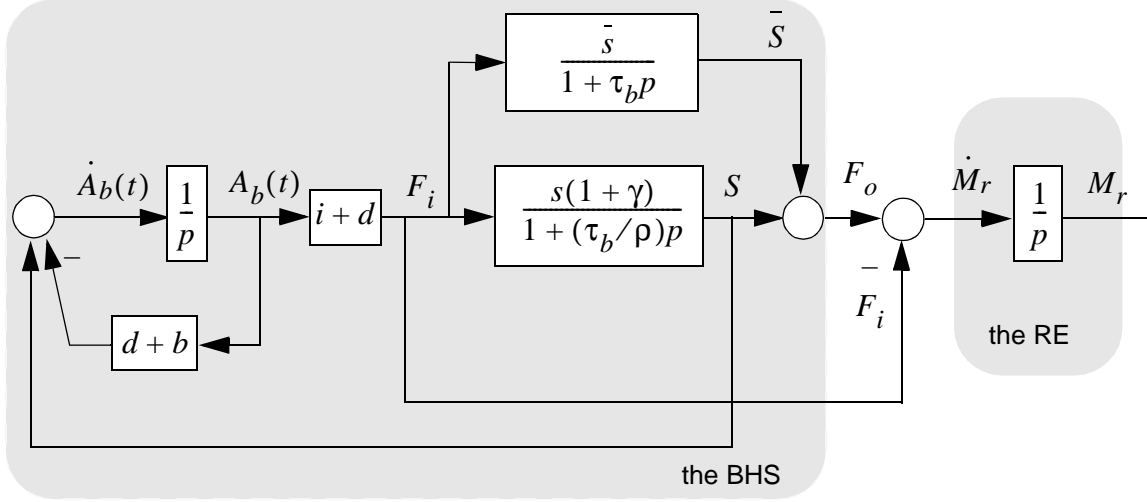

Figure 22. Linear exponential growth subsystem

This model part is linear when, as assumed, $b = \text{constant}$. Fig. 22 corresponds to part of the structure in Fig. 19, except for the introduction of the differentiation operator p . Employing the Laplace transformation, with A_b given by Eq. 30, we get

$$F_o(t) = ae^{\lambda t} (i + d) \left(\frac{\bar{s}}{1 + \tau_b \lambda} + \frac{s(1 + \gamma)}{1 + (\tau_b/\rho)\lambda} \right) \quad (31)$$

Substituting Eq. 31 for $F_o(t)$ in Eq. 29, and making use of $\dot{A}_b/A_b = \lambda$ and $\dot{T}_r = 0$ for large t , we get

$$0 = \left(\frac{\bar{s}}{1 + \tau_b \lambda} + \frac{s(1 + \gamma)}{1 + (\tau_b/\rho)\lambda} \right) - 1 - T_r \lambda \Rightarrow$$

$$T_r = \frac{1}{\lambda} \left(\frac{\bar{s}}{1 + \tau_b \lambda} + \frac{s(1 + \gamma)}{1 + (\tau_b/\rho)\lambda} - 1 \right) \quad (32)$$

Eq. 32 is valid for non-collapse scenarios for large values of t . Since we must demand that $T_r > 0$, we get the following necessary condition for avoiding collapse,

$$\frac{1-s}{1+\tau_b\lambda} + \frac{s(1+\gamma)}{1+(\tau_b/\rho)\lambda} > 1 \quad (33)$$

This inequality confirms intuitive notions about the role of γ and τ_b : New money must be generated, or liquidity preference in the BHS (or transaction activity within the BHS, *which amounts to the same, seen from the RE*), must be curbed. The factor ρ which is a constant for large t , have not been explicitly solved for, but it is per definition < 1 . The asset growth parameter will also have become a constant, and it may be shown that it satisfies the equation

$$\lambda = -d - b + \frac{s(1+\gamma)}{1+(\tau_b/\rho)\lambda}(i+d) \quad (34)$$

We do not, however, need to solve for λ to make meaningful comments. We observe from Eq. 34 that the effect of the flow $s(i+d)A_b$ having to pass through the low-pass filter that is the financial sector before emerging as loans back to the RE, has the effect of slightly reducing asymptotic asset growth rate λ . Without this filter, which has the time lag τ_b/ρ , we would have had $\lambda = -d - b + s(1+\gamma)(i+d)$, i.e. slightly faster asset growth.

For cases still avoiding collapse but close to bifurcation, Eq. 33 and Eq. 34 indicate some effects of specific parameter changes. We observe that increasing the interest rate or lowering the repayment rate (the latter means that perpetuities and rolling over debt are on the increase) is dangerous, since both denominators in Eq. 33 will increase.

We note as already stated that money creation ($\gamma > 0$) is necessary. If, however, the money growth rate surpasses real output growth rate (assuming that money velocity does not decrease), we will have inflation, and black holes will increase interest rates to compensate for this. Therefore a useful elaboration on the model would be to incorporate a physical output growth sub-model to calculate price growth, and feed back from inflation rate to interest rate. This, however, is beyond the scope of this paper.

The scenario of debt overwhelming an economic system is not unique for this paper. It has been a topic for public concern since antiquity, and warnings are for instance given in the Bible. An early academic contribution with a mathematical model of debt growth is (Domar, 1944). While he models and discusses exponential growth of (in his case, public) debt, his purpose is not warn against it; quite the opposite. Domar uses a scenario with exponential growth in all economic indicators to argue that ever increasing public debt is no problem, in a polemic against those who argue for government austerity to curb growth in public debt. His model divides society into public debt bond-holders (Bs) and non-bond-holders (NBs).

He assumes the following (we will use Domar's notation): The aggregate nominal income flow Y of NBs grows exponentially, $Y = ae^{rt}$, where a is the initial income flow and r is a growth rate. The public debt D is increased at the same rate, with \dot{D} a fixed fraction α of NBs' income flow; we have $\dot{D} = \alpha Y = \alpha ae^{rt}$. The part of taxes used to pay the interest burden, $U = iD$, is levied upon both NBs and Bs with identical tax rates. Total taxable income is $T = Y + U$, where the two terms are income to NBs and Bs, respectively. The necessary tax rate for the interest burden part of taxes is then U/T .

Based on this model, Domar shows that the debt burden, for instance defined as the ratio between debt service flows and NBs income, does not overwhelm the system, but tends towards a manageable constant value: The result is $iD/Y \rightarrow i\alpha/r$ as $t \rightarrow \infty$. This supports his proposition that growing public debt is no problem.

Domar's argument rests upon an assumption of exponential growth in NBs' nominal income flow. But by assuming this at the outset, he also excludes the possibility for financial crisis. The NB aggregate roughly corresponds to what in this paper has been called the RE. Sustainable exponential nominal growth in RE flows, for instance Y , requires an exponentially growing money stock in the RE. Domar assumes that public debt is created by selling bonds, which as opposed to bank lending, *does not increase money stock*. Thus his analysis must

(without saying so) necessarily assume exponential growth in bank lending at the same rate as that of public debt, to achieve the needed exponential money growth. Then we have a scenario which is similar to that explored in this paper, and where a collapse is a distinct possibility

Another, and recent, work on the modeling of debt-related dynamics, is (Keen, 1997) who combines the long-range accumulation mechanism with worker-capitalist interaction leading to cycles in employment and the income shares ("business cycles"). Keen expands Goodwin's (1967) two-state worker-capitalist model which explains business cycles but has no long-term dynamics except exponential output growth, by adding a finance sector which reinvests banks' financial income from loans to capitalists. At a realistic interest rate level, this leads to collapse of the system because of the increasing debt burden.

Keen's model and the model presented in this paper are quite different: Keen's model has short-term fluctuations due to worker-capitalist interaction, while this paper abstracts from that. Keen's model incorporates real output, while this model ignores real output and regards the economy as a network of cash flows. Keen's model ignores money stock and flow/stock dynamics, in this paper money stocks are system states along with aggregate assets (which corresponds to Keen's aggregate debt). Keen's model has behavioural assumptions about capitalist's willingness to invest (and borrow) based on profit share, while this paper's main behavioural assumption is about liquidity preference as a function of incidence of losses. Keen's model has financial, capitalist and worker agents, while this model has net creditor and debtor agents, where firms are if necessary split into the two categories. Keen's model regards interest on loans only, while this model considers all sorts of financial returns, including that from stock. Keen's model works in deflated terms, this paper in nominal terms.

In spite of differences, both models predict collapse following the inexorable increase in debt burden due to compound financial returns. In Keen's model the debt increase is modified by short term cycles, but since debt is not repaid fully during a cycle, it starts out higher before

the next. Thus it essentially grows monotonically in the long term, as it does following the model in this paper.

The fact that two quite different models predict essentially the same dramatic end result, demonstrates the importance of compound financial returns, but also that more research remains to be done in this area.

Concluding remarks

The strong focus on money and finance in this paper must not be understood such that the real economy is considered secondary. Indeed, the primary concern of economics should be the satisfaction of real needs. But the described financial phenomena run their course regardless of real economy developments, and sooner or later also influence the real economy negatively.

We may sum up the results as follows: If accumulation proceeds faster than money growth among debtors, then polarization will develop, the financial sector will grow relatively, and the process will in the long run end up in acute crisis.

The analysis given refutes the following oft-heard argument against criticism of a society where a minority control a disproportionate and increasing share of the available buying power: "Even if distribution of wealth and income may be strongly unfair, the capitalists consume or invest, so jobs are created anyway." This view is, as demonstrated, too simplistic: The crisis mechanism has nothing do with lack of fairness *as such*.

An inspiration for this paper has been John Hotson, who sounds the alarm against the unsustainable worldwide indebtedness process (Hotson, 1994). What he says verbally is hopefully further illuminated by the model developed here. The world faces a problem which is not only *mathematically* similar to exponential population growth, but also similar in gravity. But, while the challenge of the population explosion is widely recognized, the debt explosion is ignored, sadly also by a large part of the economics profession.

From the above follows that macroeconomic policies ensuring low interest rates and sufficient money growth, should have top priority. Thus policies exclusively "targeted against inflation" are dangerous. A more drastic remedy is that *one simply should not allow systematic capital accumulation through financial mechanisms* in a society. "Accumulation" would then only take place as *temporary* amassing of financial assets due to an agent being especially clever or diligent in real-economic activity. Such assets would then in the next round be dispersed due to the same agent's consumption or investment (in the real sense, not in the AFR sense).

This author suggests that the "inverse fragility factor" T_r defined in Eq. 24 should be an important indicator for long-range macroeconomic policy-making: It should not be allowed to decrease below a given level. Alternatively, $v_r = 1/T_r$, which could be called the "required debtor money velocity", should not be allowed to *exceed* a certain level. While it is fully feasible to estimate and employ this factor for planning and policy purposes, this is not done today.

The compounding of returns on all sorts of financial assets seems to this author to be the prime cause of long-term crises or depressions in the world economy. The described dynamics could be considered a candidate explanation for the, admittedly controversial, concept of "long waves" in capitalist economies.

References

- Andresen, Trond (1996). Economic black Holes - The dynamics and consequences of accumulation. *Économies et Sociétés, Série Monnaie et Production* 10, No. 2-3, pp 83-116.
- Domar, E. D. (1944). "The burden of debt" and the national income. *The American Economic Review*, vol 34 (December), pp. 798-827. Reprinted in: Domar, E. D. (1957). *Essays in the theory of economic growth*. Oxford: Oxford University Press, pp 35-69.
- Dornbusch, R. and Fischer, S. (1994). *Macroeconomics*. New York: McGraw-Hill, Inc.
- Goodwin, R. M. (1967). A growth cycle. In: Feinstein, C. H. (Ed.), *Socialism, capitalism and economic growth*. Cambridge: Cambridge University Press, pp. 54-58.
Reprinted in Goodwin, R.M. (1982), *Essays in dynamic economics*. London: MacMillan.
- Hotson, John H. (1994). Financing sustainable development.
Économies et Sociétés, Série Monnaie et Production 9, No. 1-2, pp 359-373.
- Keen, Steven (1997). *Economic Dynamics: From Exogeneity to Complexity*.
Nonlinear Dynamics, Psychology, and Life Sciences, Vol. 1, No. 2.
- Lavoie, Marc (1992). *Foundations of post-Keynesian economic analysis*.
Aldershot, England: Edward Elgar.
- Minsky, Hyman P. (1986). *Stabilizing an unstable Economy*,
New Haven and London: Yale University Press.