

“Archie”: A Cost Oriented Humanoid Robot

A. Byagowi*, P. Kopacek*, J. Baltes**

*Intelligent Handling and Robotics (IHRT), Vienna University of Technology
Tel: 431-50881-31800; e-mail: kopacek@ihrt.tuwien.ac.at).

**Department of Computer Science, University of Manitoba (e-mail:
jacky@cs.umanitobca.ca)

Abstract: This paper is a brief description of the cost oriented humanoid robot Archie. Archie has been developed in Vienna University of Technology. Later on the software development of Archie extends on collaboration with the Department of Computer Science from the University of Manitoba. Archie is constructed by using brushless motors and harmonic gears with a novel approach for finding the absolute position as part of the work on the robot. The experience gained from the development of small humanoid robots is used to develop the software of Archie, to create, store, and play back motions. The software of the robot is aimed to be developed in a level to control automatically the balance of the robot by using feedback from an internal measurement unit (IMU). The main goal was to develop a reasonable cheap, teen sized humanoid robot for supporting humans in everyday life.

Keywords: Humanoid Robot, Brushless Motor, Cascade Controller, Absolute Sensor, System on Chip

1. INTRODUCTION

Humanoid robots have always inspired the imagination of robotics researchers as well as the general public. Up until 2000, the design and construction of humanoid robots was very expensive and limited to a few well-funded research labs and companies (e.g., Honda Asimov, Fujitsu HOAP). Starting in about 2001 advances in material sciences, motors, batteries, sensors, and the continuing increase in processing power available to embedded systems developers has led to the development of many small humanoid robots, but also allowed the creation of the next generation of humanoid robots that are between 1.3m and 1.8m tall. The creation of these humanoid robots also coincided with an increased interest in several high profile researches oriented international robotics competitions (e.g., RoboCup Federation, 2001 and FIRA (Baltes and Braunl, 2004)). The researchers chose robotic soccer as a challenge problem for the academic fields of artificial intelligence and robotics.

Robot soccer requires a large amount of intelligence at various levels of abstraction (e.g., offensive vs. defensive strategy, role assignment, path planning, localization, computer vision, motion control). Robot soccer is a dynamic real-time environment with multiple agents and active opponents that try to prevent the robot from achieving its goal. These competitions allowed researchers to compare their results to others in a real-world environment. It also meant that robustness, flexibility, and adaptability became more important since these robots had to perform for extended periods of time in variable conditions.

This is in contrast to researchers that could previously fine tune their system to the specific conditions in their laboratory. The inaugural humanoid robotics competition at RoboCup and at FIRA was held in 2002.

2. MECHANICAL CONSTRUCTION OF ARCHIE

Archie is a cost oriented anthropomorphic robot constructed with the aim to support and assist human in everyday life. The robot entails 30 degree of freedom. The hierarchical diagram of the constructive joint of the robot is illustrated in Fig. 1.

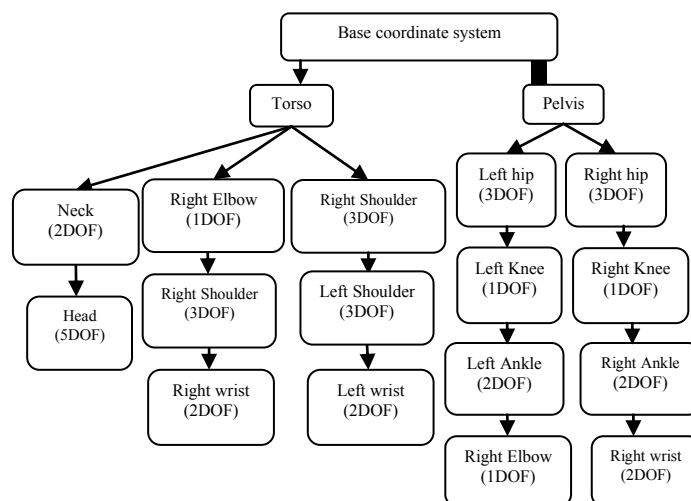

Fig. 1. Hierarchical diagram of the joints used to construct the robot

Archie is a 1.5m tall humanoid robot with 30 degrees of freedom (DOF). There are seven DOF in each leg: three DOF in each hip, one in the knee, and two in the ankle. Archie is one of the few humanoid robots that have activated toes, which allow it to roll over the foot when walking. The torso contains two degrees of freedom. Each arm has three DOF, two in the shoulder and one in the elbow. The head entails three DOF which allow it to pan, tilt, and sway.

Besides, one DOF control the opening and closing of the mouth. Fig. 2 shows the kinematic model of the main actuators of Archie. The actuators in the head are omitted for clarity.

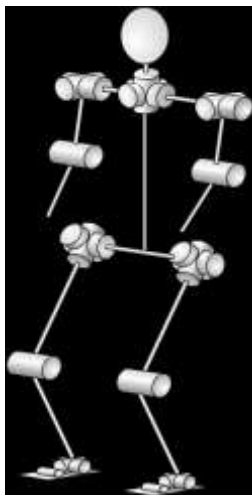

Fig. 2. Archie's kinematics

The constructive joints of the robot are in variation of degree of freedom based on the demand (e.g., the hip joint is construction of three degree of freedom, while the knee joints uses only one degree of freedom).

2.1 Joint actuators

Three types of motors are used in Archie for actuating the joints: brush-less motors, DC motors and RC motors. Some of the key benefit of using a brush-less motor in Archie are increased efficiency and less noise of the motor. However, control of a brush-less motor requires more complex control logic, but allows for finer control. Given those advantages it would have been sensible to use only brush-less motors for Archie, but to save cost; the joints that do not need to generate very high torque were implemented via DC motors.

2.2 Servo motor based joints

The constructive joints of Archie are divided in the types; the upper body joints which are made from standard servo motors, see Fig. 3.



Fig. 3. RX-64 servo motor used in Archie (Dynamixel, 2010)

2.3 Brushed DC motor based joints

The transversal joints as well as the Ankle frontal joint and the toe joints are constructed of brushed DC motors. Main reason

for using these motors (instead of Brushless motors) is the mechanical space restriction. In the interest of having human like shape for the robot some of the parts of the robot should contain several degree of freedoms, while using Brushless motors for all these joints requires more mechanical space. As an instance the pelvis of the robot need three degree of freedom for each joint beside two degree of freedom of the back bone (the attaching part of the torso). All together eight degree of freedom should be placed in the shape of human's pelvis. Thus three of the required motors (used in the transversal movement joints) are constructed of brushed DC motors (Fig. 4).

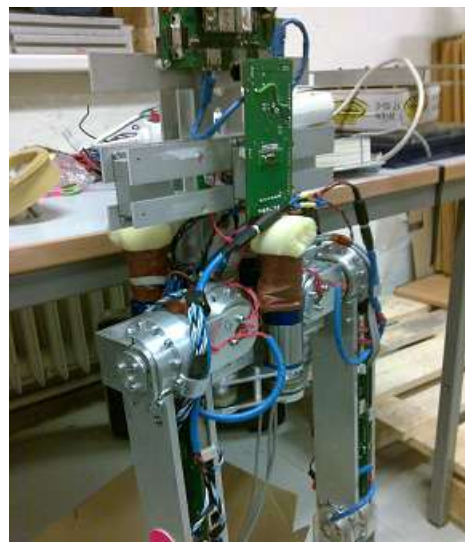

Fig. 4. Pelvis of the robot which contains eight motors (8 DOF)

2.4 Brushless DC motor based joints

Archie's important joints are constructed of brushless DC motors (9 of 30 joints). These joints are located in the lower body of the robot and are high demanded for controlling the robot during walking. The Brushless DC motor based joints are fully controlled by cascade controller (Fig 5).

In the brushless DC motor based joints harmonic drive gears are used. Main reason for using this type of gears is the low backlash. Besides, the harmonic drives provide high ration and reliability in a compact and optimize space which will provide the design the ability to arrange human shape for the robot (Fig 6).

3. BALANCE CONTROL

The control for a humanoid robot is saving the mechanical balance of the robot by controlling the total center of mass of the robot. The calculation to find the total center of mass is based on the direct kinematic of the robot. Since a humanoid robot contains multiple joints, the calculation of the direct

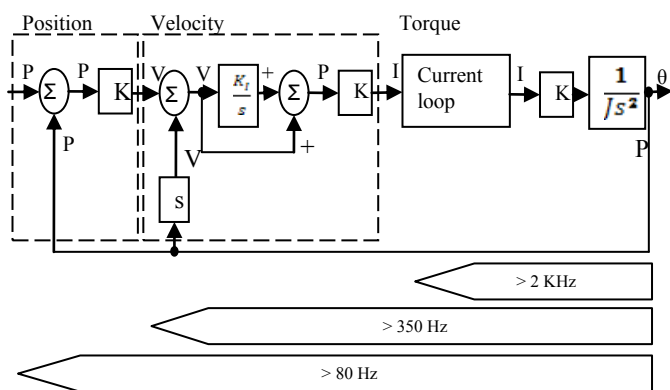

Fig. 5. Brushless motor's motion controller bandwidth (ELMO Company, 2010)



Fig. 6. The Ankle of the robot by using harmonic drive gear to arrange human shape for the robot

kinematic is more sophisticated. Moreover, the total center of mass of the robot should be calculated in a unique coordinate system (Base coordinate system). In this robot the Denavit-Hartenberg convention is used to simplify this process. By using the homogeneous transformation and using the Denavit-Hartenberg convention the location of the center of mass for each link of the robot is relocated in the base coordinate system. Using classical center of mass calculation, see equation 1, the total center of mass for the robot is calculated.

$$CM_{total} = \frac{1}{m_{total}} \sum m_i CM_i \quad (1)$$

Since the links of the robot are made of rigid bodies, the location of the center of mass for each link is stationary regarding to the coordinate system of the link. Nonetheless the overall pose of the robot changes the position of the center of mass for link in the base coordinate system and sequentially changes the total center of mass of the robot. Table 1 shows the location of the center mass from each link based on its coordinate system beside its mass.

Tab. 1. Mass and position of center of mass for each link based on its origin coordinate system

Link Name	Mass	Center of mass X	Center of mass Y	Center of mass Z
L1	0.125kg	0mm	-53mm	-4mm
L2	0.111kg	0mm	-4mm	-26mm
L3	0.008kg	0mm	0mm	-5mm
L4	0.075kg	28mm	0mm	-130mm
L5	0.131kg	98mm	0mm	-155mm
L6	0.048kg	58mm	23mm	0mm
L7	0.049kg	0mm	0mm	25mm
L8	0.346kg	75mm	70mm	-15mm
L9	0.049kg	0mm	0mm	22mm
L10	2.992kg	0mm	33mm	249mm

3.1 Non-linearity in control of the joints

Since a humanoid robot is a non-linear system, controlling a humanoid robot needs to be non-linear. The gravitational forces and the variation of the reflected load's moment of inertia on each joint are two causes of the non-linearity of the robot. Modeling the robot in order to anticipate the variation of the load specification as well as the inclusion of the gravitational effect on the robot can provide the required data to control the joints of the robot. As an instance the variation of the gravitational force on the lateral hip joint based on its angle and the angle of the knee joint is mode and illustrated in Fig. 7.

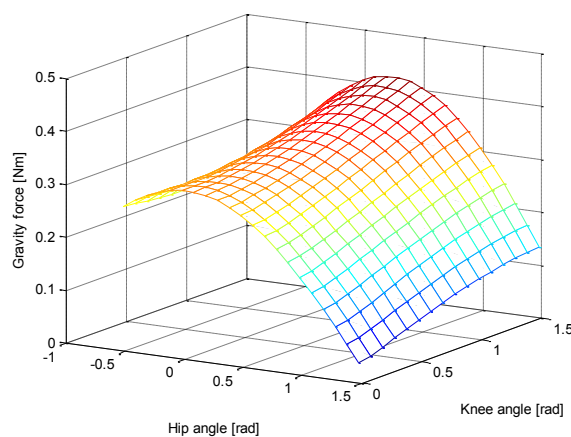

Fig. 7. Gravity force for swinging leg on knee and hip angle changing

3.2 Central controller of the robot

The control controller of the robot consists of a System-on-chip architecture (SOC). Based on SOC, an embedded system with the minimal peripherals is fitted on a chip in order to reduce the cost and the size of the design. Fig. 8 shows the Virtex 4 FPGA used to implement the required system-on-chip for the central control of the robot.



Fig. 8. Virtex 4 FPGA used to implement the system-on-chip for the central controller

The prepared hardware for the central controller can run a standard Linux operating system in order to simplify the development of the robot. The central controller board is depicted in Fig. 9.



Fig. 9. Central controller board

The minimum system for running the standard Linux OS is implemented on a System on Chip (SoC) to reduce the power consumption beside, increasing the flexibility of the system design and reliable platform. Fig.10 shows on-chip system design used for the central controller of the robot.

4. ABSOLUTE POSITIONING

Determining the absolute position is necessary for all the joints of Archie except the RC servo motors. In the toe joint the positioning is made by using incremental positioning system. The positioning in the toe is based on a zero point and requires that the motor moves to a fixed position at start up. Thereafter, the position will be determined using

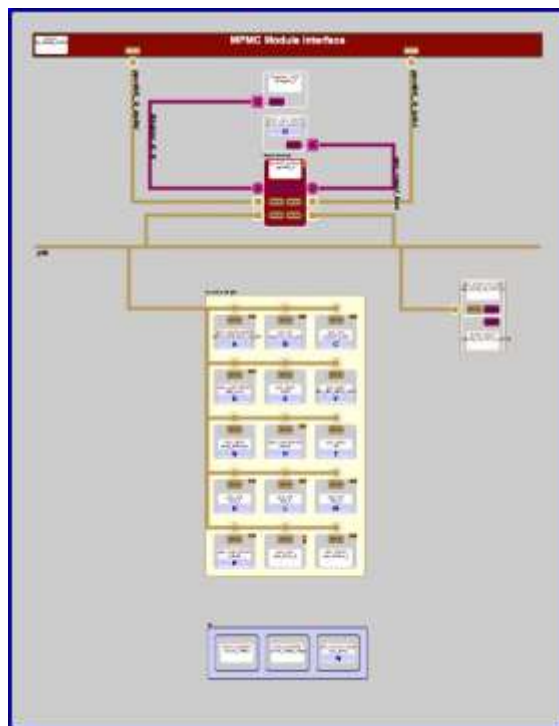

Fig. 10. Block diagram of the control system of Archie (Byagowi 2010)

incremental encoders that are mounted on the motor. For the heel joint a permanent magnet and a Hall sensor based absolute encoder is used to the correct position of the joint. This design only needs to be calibrated once during construction.

4.1 Contact-free Position Encoders for Brushless Motors

The most common approach to determining the absolute position of the motor is to use end-switches. However, this approach requires the robot to move into possibly unstable positions at initialization, which is unsuitable for large and expensive adult sized humanoid robots.

In this method an absolute Hall sensor chip (AS 5134, see [Company, 2010a]) is used which entail four Hall sensors, a flash analog to digital converter (ADC), an embedded micro-controller. Fig. 11 and 12 shows the basic operation and the block diagram of the AS 5134. The AS5134 is a complex chip that provides several access methods. In Archie, the incremental encoder feedback is used directly by the ELMO motion controller and the synchronous serial interface (SSI) is used to read absolute position and magnet strength information from the chip.

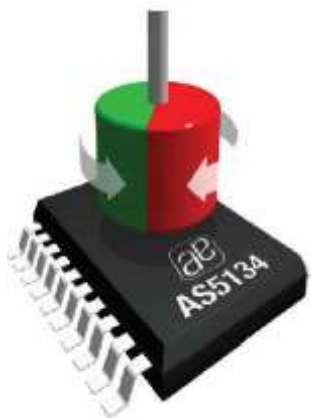

Fig.11. AS 5134 Hall Sensor (Austrian Micro Electronics 2010)

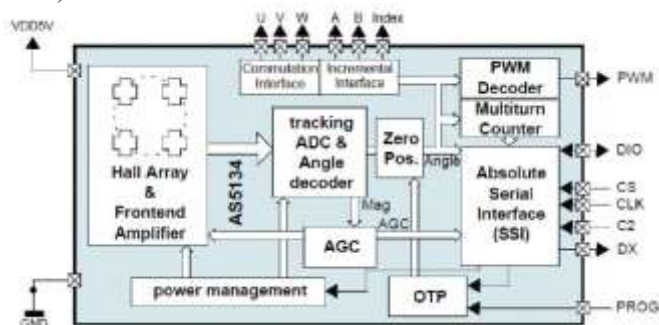

Fig.12. Block diagram of AS 5134 Hall Sensor (Austrian Micro Electronics 2010)

A drawing of our sensor assembly is shown in Fig. 13. This chip is mounted on the output shaft of the gear box and measures the position of a magnet mounted on the motor shaft. A gear box provides a 1:160 reduction in speed and increase in torque respectively. The absolute position sensor is mounted on the next link (i.e., the output of the gearbox).

The magnet rotates with the output of the motor. An index signal is generated by using a Hall switch. By testing this signal, the controller can move the motor shaft to a known position. Once the motor shaft is in a known position, the absolute position of the magnet is measured via the sensor mounted on the next link.

One consideration is that the absolute position sensor is not fixed to the frame of the previous link, but rotates with the next link, which results in a relative motion of the absolute sensor with respect to the magnet. Each 360 degree turns of the motor results in a 2.25 degree movement of the sensor. The sensor also provides the encoder signals for the motion controller, but the relative motion of the sensor and the magnet results in a compression or stretching of the encoder signals, which in turn leads to an error when controlling the motion. For example, the incremental encoder signals will be stretched if the motor and the link turn in the same direction. Thus the next link will turn $360 + 360/160$ degrees instead of the desired 360 degrees. If the motor and link turn in opposite directions, the encoder signals will be compressed resulting in $360 - 360/160$ degrees instead of the desired 360 degrees.

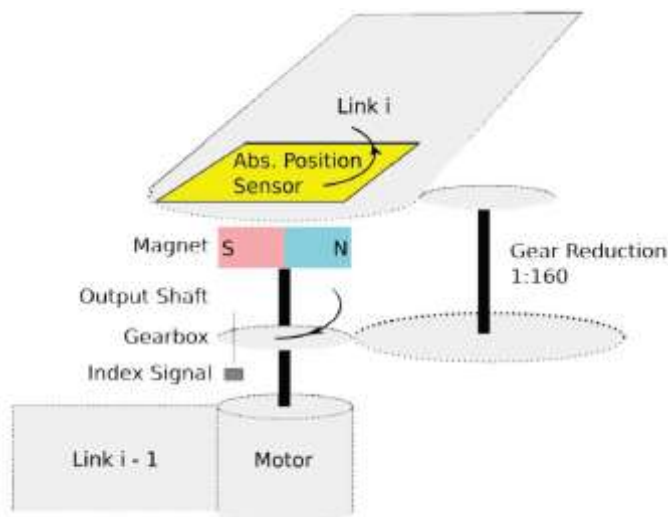

Fig.13. Contact less Absolute Positioning System

In our case, the gearbox and motor turn in the same direction, which results in a stretching of the encoder signals. However, since the relationship is determined by the gearbox, a correction signal can easily be calculated from (2).

$$\dot{m}_{rel} = m_{rel} + m_{rel} \frac{360^\circ}{G} \quad (2)$$

Where \dot{m}_{rel} is the corrected relative motion command, m_{rel} is the desired relative motion command, and G is the gear ratio (A. Byagowi 2010).

5. CONCLUSION

In this paper is a brief description of the cost oriented humanoid robot Archie is given. Cost Orientation is reached by an extremely light weight construction, by using of standardized joints consisting of brushless motors and harmonic gears with a novel approach for finding the absolute position. Furthermore main modules of the software came from experiences with small humanoid robots to create, store, and play back motions. The software of the robot is aimed to be developed in a level to control automatically the balance of the robot by using feedback from an internal measurement unit (IMU). The main goal was to develop a reasonable cheap, teen sized humanoid robot for supporting humans in everyday life.

REFERENCES

- A. Byagowi (2010), *Control System for a Humanoid Robot*, PhD Thesis, Vienna University of Technology.
- Elmo Company. *Elmo Whistle*. Webpage, April 2010b. Last visited on 25 April 2010.
- Austriamicrosystems Company. AS 5134. Webpage, April 2010a. Last visited on 25 April 2010.
- Dynamixel Company. RX-64. Webpage, April 2010a. Last visited on 25 April 2010.